

# 2.54mm Pitch Low Profile Connector

## HIF3FB and HIF3FC Series

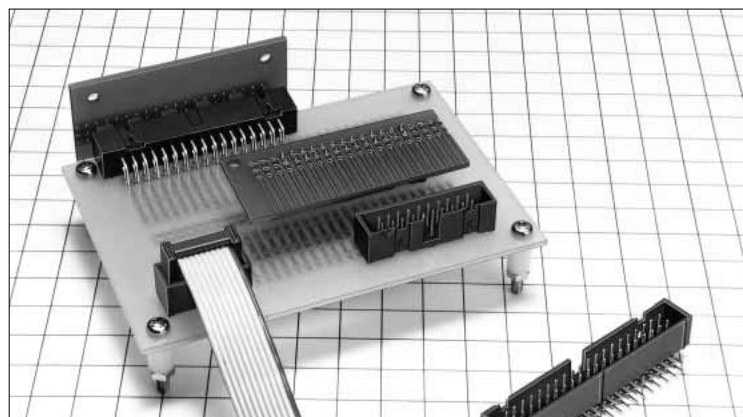

Photo: HIF3FC Series

### ■ Features

#### 1. Flux Prevention

HIF3FC series straight type takes complete flux tight measures.

#### 2. Low Profile

The pin header is a low profile of height 9.2mm.  
 The board to board clearance is 12.2mm for stacking connection.

### ■ Applications

Computers, termination equipment, various kinds of electronic equipment, Office Automation machines and so on

### ■ Product Specifications

Rating	Current rating: 1A Voltage rating: 200V AC	Operating Temperature Range: -55 to +85°C (Note 1) Operating Humidity Range: 40 to 80%	Storage Temperature Range: -10 to +60°C (Note 2) Operating Humidity Range: 40 to 70% (Note 2)
--------	---	---	--

Item	Specification	Condition
1. Insulation Resistance	1000M ohms	500V DC
2. Withstanding Voltage	No flashover or insulation breakdown.	650V AC/1 minute.
3. Contact Resistance	15m ohms max.	0.1A
4. Vibration	No electrical discontinuity of 1μs or more	Frequency: 10 to 55 Hz, single amplitude of 0.75 mm, 2 hours in each of the 3 directions.
5. Humidity (Steady state)	Insulation resistance: 1000M ohms min	96 hours at temperature of 40°C and humidity of 90% to 95%
6. Temperature Cycle	No damage, cracks, or parts looseness.	(-55°C: 30 minutes→15 to 35°C: 5 minutes max.→ 85°C: 30 minutes→15 to 35°C: 5 minutes max.) 5 cycles
7. Durability (Mating/un-mating)	Contact resistance: 15 m ohms max.	500 cycles
8. Resistance to Soldering heat	No deformation of components affecting performance.	Solder bath: 260°C for 10 seconds
		Manual soldering: 350°C for 3 seconds

Note 1: Includes temperature rise caused by current flow.

Note 2: The term "storage" refers to products stored for long period of time prior to mounting and use. Operating Temperature Range and Humidity range covers non conducting condition of installed connectors in storage, shipment or during transportation.

Note 3: Information contained in this catalog represents general requirements for this Series. Contact us for the drawings and specifications for a specific part number shown.

### ■ Material

Parts	Material	Finish	Remarks
Insulator	PBT	Black	UL94V-0
Contact	Pin header	Brass	Contact area : Gold plated
	Receptacle	Copper alloy	Termination area : Pure tin plated

### ■ Ordering Information

## HIF3FC- \* P A - 2.54 DSA

①      ②      ③      ④      ⑤      ⑥

① Series Name : HIF3FB (60, 64 contacts) : HIF3FC (10~50 contacts)	④ A: Selective gold plating ⑤ Contact pitch: 2.54mm
② Number of contacts: 10, 14, 16, 20, 26, 30, 34, 40, 50, 60, 64	⑥ Contact type DSA : Straight type DS : Right angle type
③ P : Pin header D : Socket	

HIF3FB and HIF3FC Series 2.54mm Pitch Low Profile Connector

### ■ Straight Type Pin Header

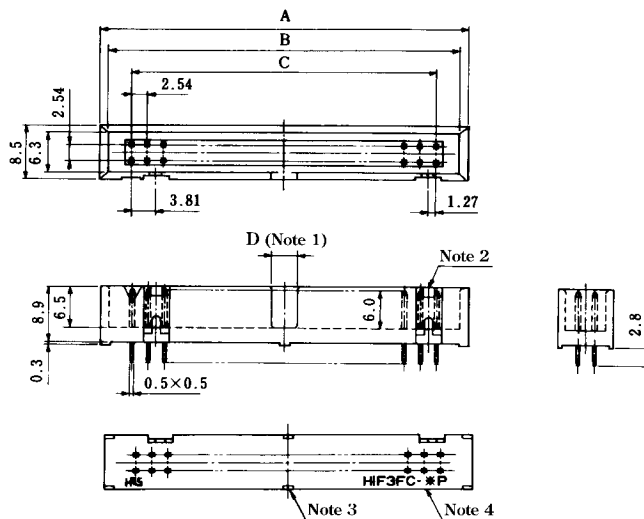
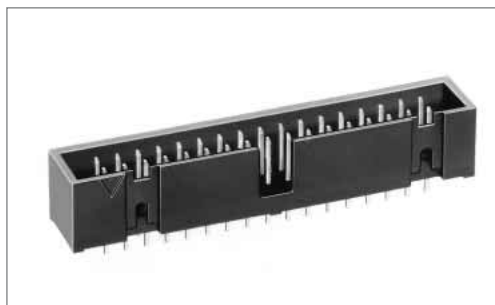

- Note 1: Two types of 50 contacts are available. Please use products according to the table as shown below.
- Note 2: The number of polarizing key mounted positions differs according to products. Please refer to the table as shown below.
- Note 3: The 10 contact type has no standoff at the center.
- Note 4: \* indicates the number of contacts.

Unit: mm

Part Number	CL No.	Number of Contacts	A	B	C	D (Note 1)	Polarizing Key Mounted Position(Note 2)	RoHS
HIF3FC -10PA-2.54DSA(71)	616-0161-4-71	10	20.2	17.5	10.16	4.1	None	YES
HIF3FC -14PA-2.54DSA(71)	616-0162-7-71	14	25.28	22.58	15.24	4.1	1 point on the left side	
HIF3FC -16PA-2.54DSA(71)	616-0163-0-71	16	27.82	25.12	17.78	4.1	1 point on the right and left sides, respectively	
HIF3FC -20PA-2.54DSA(71)	616-0164-2-71	20	32.9	30.2	22.86	4.1		
HIF3FC -26PA-2.54DSA(71)	616-0165-5-71	26	40.52	37.82	30.48	4.1		
HIF3FC -30PA-2.54DSA(71)	616-0166-8-71	30	45.6	42.9	35.56	4.1		
HIF3FC -34PA-2.54DSA(71)	616-0167-0-71	34	50.68	47.98	40.64	4.1		
HIF3FC -40PA-2.54DSA(71)	616-0168-3-71	40	58.30	55.60	48.26	4.1		
HIF3FC -50PA-2.54DSA(71)	616-0169-6-71	50	71.0	68.3	60.96	4.1		
HIF3FCA-50PA-2.54DSA(71)	616-0170-5-71	50	71.0	68.3	60.96	26.96		

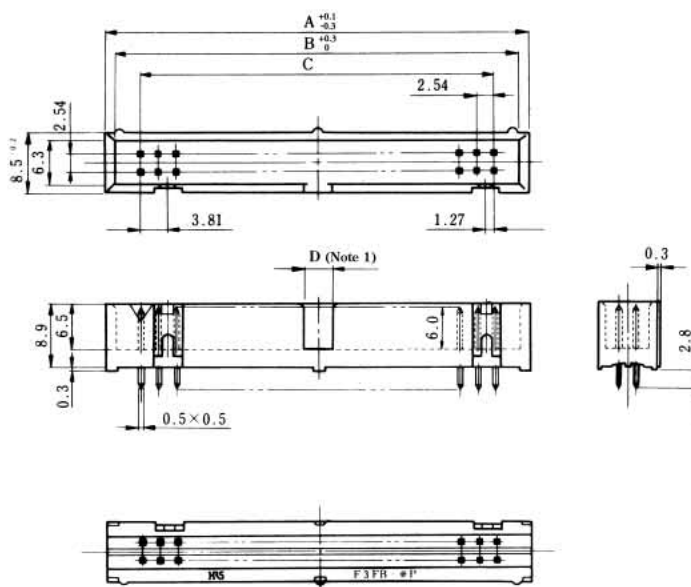
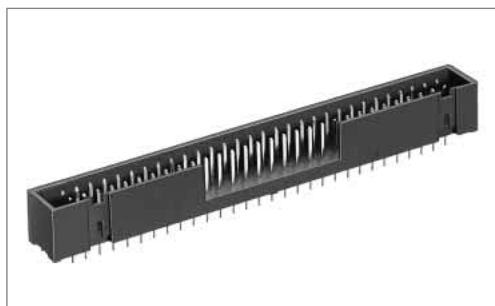

- Note 1: Two types are available. Please use them according to the table as shown below.

Unit: mm

Part Number	CL No.	Number of Contacts	A	B	C	D (Note 1)	Polarizing Key Mounted Position	RoHS
HIF3FB -60PA-2.54DSA(71)	616-0130-0-71	60	83.7	81.0	73.66	4.1	1 point on the right and left sides, respectively	YES
HIF3FBA-60PA-2.54DSA(71)	616-0142-0-71	60	83.7	81.0	73.66	26.96		
HIF3FB -64PA-2.54DSA(71)	616-0131-3-71	64	88.78	86.1	78.74	4.1		
HIF3FBA-64PA-2.54DSA(71)	616-0143-2-71	64	88.78	86.1	78.74	26.96		

## Right Angle Type Pin Header

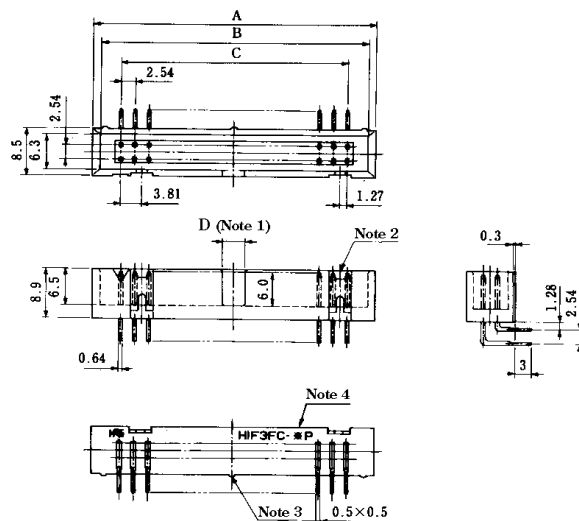
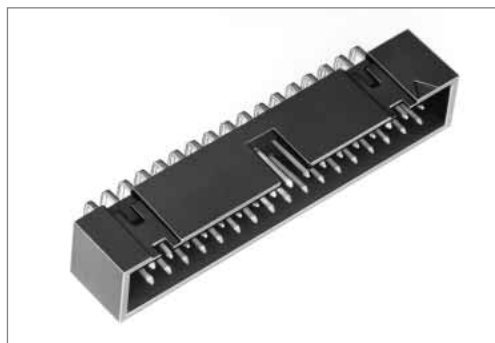

- Note 1: Two types of 50 contacts are available. Please use products according to the table as shown below.
- Note 2: The number of polarizing key mounted positions differs according to products. Please refer to the table as shown below.
- Note 3: The 10 contact type has no standoff at the center.
- Note 4: \* indicates the number of contacts.

Unit: mm

Part Number	CL No.	Number of Contacts	A	B	C	D (Note 1)	Polarizing Key Mounted Position(Note 2)	RoHS
HIF3FC -10PA-2.54DS(71)	616-0061-0-71	10	20.2	17.5	10.16	4.1	None	YES
HIF3FC -14PA-2.54DS(71)	616-0062-2-71	14	25.28	22.58	15.24	4.1	1 point on the left side	
HIF3FC -16PA-2.54DS(71)	616-0063-5-71	16	27.82	25.12	17.78	4.1	1 point on the right and left sides, respectively	
HIF3FC -20PA-2.54DS(71)	616-0064-8-71	20	32.9	30.2	22.86	4.1		
HIF3FC -26PA-2.54DS(71)	616-0065-0-71	26	40.52	37.82	30.48	4.1		
HIF3FC -30PA-2.54DS(71)	616-0066-3-71	30	45.6	42.9	35.56	4.1		
HIF3FC -34PA-2.54DS(71)	616-0067-6-71	34	50.68	47.98	40.64	4.1		
HIF3FC -40PA-2.54DS(71)	616-0068-9-71	40	58.30	55.60	48.26	4.1		
HIF3FC -50PA-2.54DS(71)	616-0069-1-71	50	71.0	68.3	60.96	4.1		
HIF3FCA-50PA-2.54DS(71)	616-0070-0-71	50	71.0	68.3	60.96	26.96		

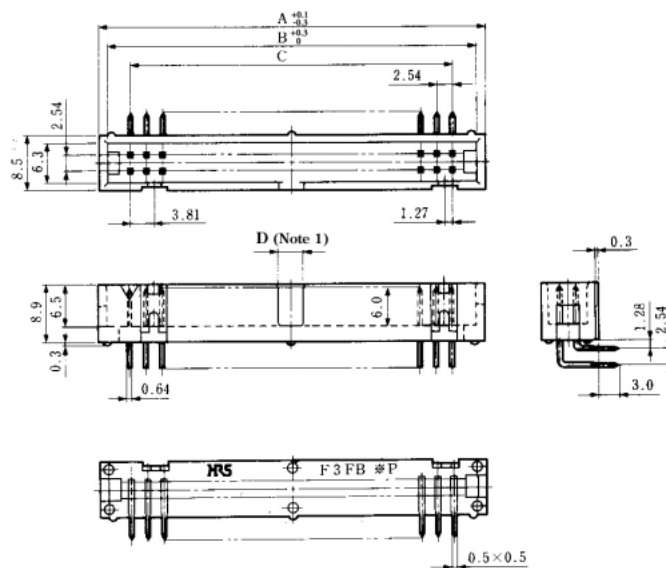
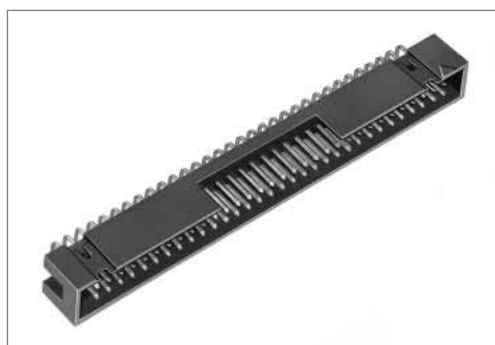

- Note 1: Two types are available. Please use them according to the table as shown below.

Unit: mm

Part Number	CL No.	Number of Contacts	A	B	C	D (Note 1)	Polarizing Key Mounted Position	RoHS
HIF3FB -60PA-2.54DS(71)	616-0030-6-71	60	83.7	81.0	73.66	4.1	1 point on the right and left sides, respectively	YES
HIF3FBA-60PA-2.54DS(71)	616-0042-5-71	60	83.7	81.0	73.66	26.96		
HIF3FB -64PA-2.54DS(71)	616-0031-9-71	64	88.78	86.1	78.74	4.1		
HIF3FBA-64PA-2.54DS(71)	616-0043-8-71	64	88.78	86.1	78.74	26.96		

HIF3FB and HIF3FC Series 2.54mm Pitch Low Profile Connector

## ■ Straight Type Receptacle

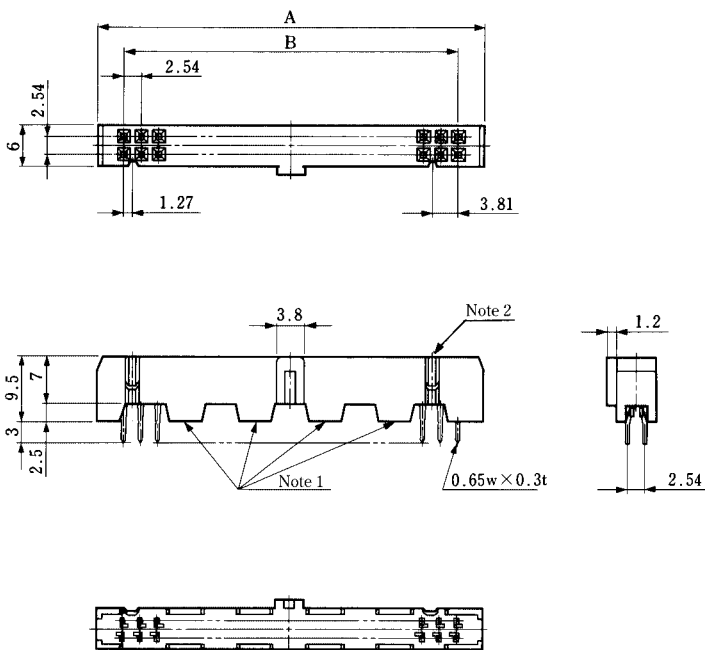
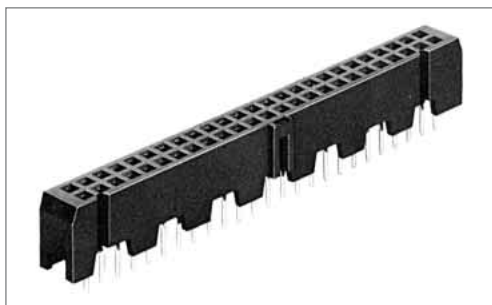

Unit: mm

Part Number	CL No.	Number of Contacts	A	B	Polarizing Key Mounted Position	RoHS
HIF3FB-10DA-2.54DSA(71)	616-0201-7-71	10	17.27	10.16	None	YES
HIF3FB-16DA-2.54DSA(71)	616-0203-2-71	16	24.89	17.78	1 point on the right and left sides, respectively	
HIF3FB-20DA-2.54DSA(71)	616-0204-5-71	20	29.97	22.86		
HIF3FB-26DA-2.54DSA(71)	616-0205-8-71	26	37.59	30.48		
HIF3FB-30DA-2.54DSA(71)	616-0206-0-71	30	42.67	35.56		
HIF3FB-34DA-2.54DSA(71)	616-0207-3-71	34	47.75	40.64		
HIF3FB-40DA-2.54DSA(71)	616-0208-6-71	40	55.37	48.26		
HIF3FB-50DA-2.54DSA(71)	616-0209-9-71	50	68.07	60.96		
HIF3FB-60DA-2.54DSA(71)	616-0210-8-71	60	80.77	73.66		

Note 1: Standoff number differs according to products.

Note 2: The polarizing key number differs according to products.