

PRODUCT NUMBER
SEE TABLE

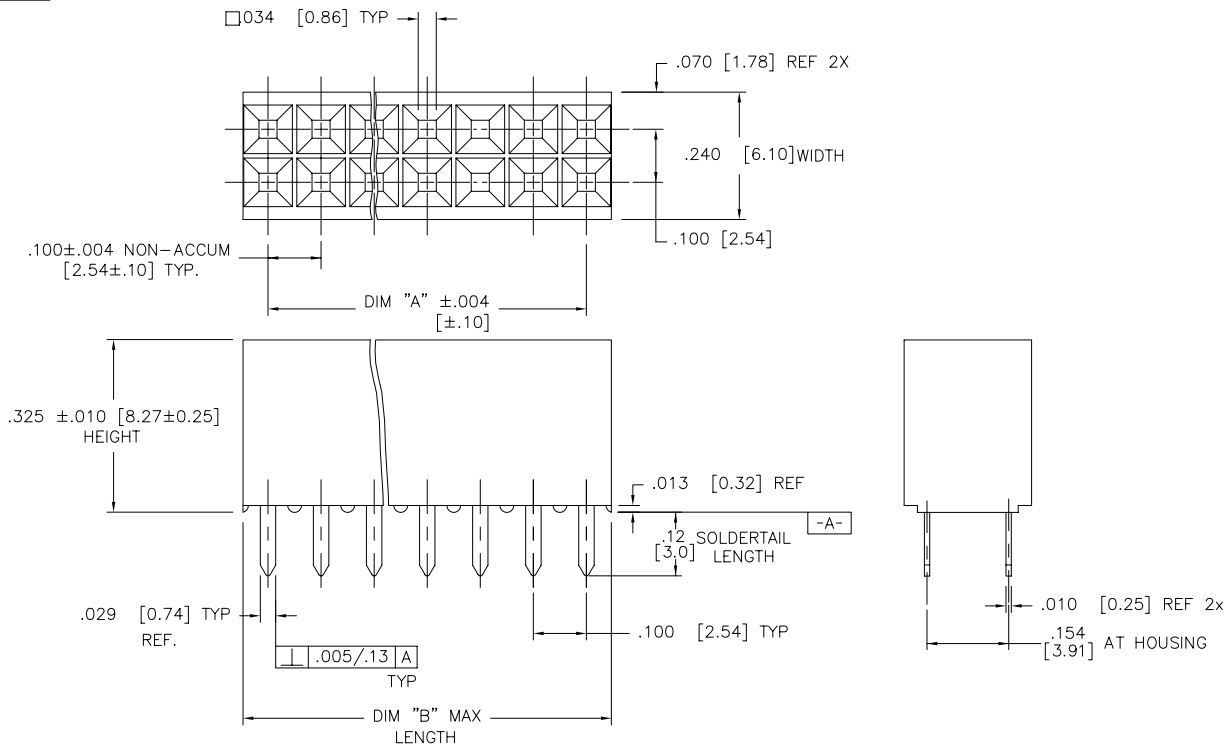

mat'l. code	surface	tolerance	projection	product family
NOTES 1 & 2	ISO 1302 ✓	ISO 406	ISO 1101	CARD CONN
tr ecd no dr date	tolerances unless otherwise specified			title
E ADD MARKING SR 2/18/91	angles	linear	INCH/MM	VERT. CARD CONNECTOR
F V23244 MRC 10/01/92	0° ± 2'		scale 4:1	.154/3.91 CTR. DOUBLE ROW
G V71141 MDF 8/7/97	dr	J.MUSTARD		FCJ
H C70056 RGD 10/13/97	enrg	M.HAHN	1/2/91	dwg no sheet 1 of 3 size
J M05-0216 ERE 10/11/05	chr	M.HAHN	1/2/91	66956 A3
K M06-0210 MHT 6/03/06	appd	M.HAHN	1/2/91	type Product Customer Drawing
L M07-0143 ERE 03/03/07	revision			
sheet index	sheet	1 2 3		

PDM: Rev:L STATUS Released Printed: Oct 13, 2010

PRODUCT NUMBER
SEE TABLE

NOTES:

- ① HOUSING MATERIAL: FILLED POLYESTER, FLAME RETARDANT PER UL 94V-0.
COLOR: BLACK.
- ② TERMINAL MATERIAL:
BODY: BRASS .010/.25 THICK.
SPRING: BeCu. HEAT TREATED
BODY PLATING: 30u"/.76u Au OVER 50u"/1.27 Ni IN CONTACT AREA.
100u"/2.54u Sn (NOTE 8) OVER 50u" /1.27 Ni ON SOLDERTAIL
SPRING PLATING: GOLD FLASH
- ③ MARK FCI PART NUMBER AND DATE CODE LEGIBLE ON TUBE LABEL.
4. APPLICATION INFORMATION.
A. RECOMMENDED MOUNTING HOLE PATTERN IS SHOWN IN FIG. #1.
B. ALL MATING PINS TO BE .025/.64 SQUARE ON TRUE CENTER OF GIVEN TERMINAL SPACINGS, WITHIN .015/.38 DIAMETER.
C. SUGGESTED MATING PIN LENGTH, .210 ±.020/5.33 ±.51.
- ⑤ ADD "LF" SUFFIX AT THE END OF PART NUMBER FOR LEAD FREE OPTION.
- ⑥ THESE PRODUCTS MEET EUROPEAN UNION DIRECTIVES AND OTHER COUNTRY REGULATIONS AS DESCRIBED IN GS-22-008.
7. THIS PART WILL WITHSTAND EXPOSURE TO 260°C PEAK TEMPERATURE FOR 20 SECONDS IN WAVE SOLDER, INFRA-RED OR VAPOR PHASE SOLDER PROCESS.
- ⑧ "THIS PRODUCT HAS 100% TIN PLATING IN THE INTERFACE AND HAS NOT BEEN TESTED FOR WHISKER GROWTH IN ALL INTERCONNECT ENVIRONMENTS."

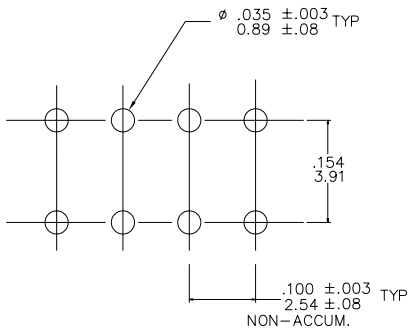

FIG.1
SCALE 5/1

mat'l. code		surface ISO 1302	tolerance ISO 406 ISO 1101	projection	product family CARD CONN
ltr	ecn no	dr	date	tolerances unless otherwise specified	title
L				angles linear XX4-01/XX4-3 XXXXX.0.005/XXXX.13 XXXXX.0050/XXXX.061	VERT. CARD CONNECTOR .154/3.91 CTR. DOUBLE ROW
				dr	dwg no
				enrg	sheet 2 of 3 size
				chr	66956 A3
				appd	type Product Customer Drawing
sheet index	revision sheet				

PRODUCT NO	NO. OF POS.	DIM A	DIM B	DESC PART NO. ON -8XX SERIES ONLY	LEAD FREE OPTION	
66956-Y01		UNASSIGNED				
-Y02	2X2	.100/2.54	.200/5.08	WWWWW-02	OBSOLETE NOTE 5,6	
-Y03	2X3	.200/5.08	.300/7.62	WWWWW-03		
-Y04	2X4	.300/7.62	.400/10.16	WWWWW-04		
-Y05	2X5	.400/10.16	.500/12.70	WWWWW-05		
-Y06	2X6	.500/12.70	.600/15.24	WWWWW-06		
-Y07	2X7	.600/15.24	.700/17.78	WWWWW-07		
-Y08	2X8	.700/17.78	.800/20.32	WWWWW-08		
-Y09	2X9	.800/20.32	.900/22.86	WWWWW-09		
-Y10	2X10	.900/22.86	1.000/25.40	WWWWW-10		
-Y11	2X11	1.000/25.40	1.100/27.94	WWWWW-11		
-Y12	2X12	1.100/27.94	1.200/30.48	WWWWW-12		
-Y13	2X13	1.200/30.48	1.300/33.02	WWWWW-13		
-Y14	2X14	1.300/33.02	1.400/35.56	WWWWW-14		
-Y15	2X15	1.400/35.56	1.500/38.10	WWWWW-15		
-Y16	2X16	1.500/38.10	1.600/40.64	WWWWW-16		
-Y17	2X17	1.600/40.64	1.700/43.18	WWWWW-17		
-Y18	2X18	1.700/43.18	1.800/45.72	WWWWW-18		
-Y19	2X19	1.800/45.72	1.900/48.26	WWWWW-19		
-Y20	2X20	1.900/48.26	2.000/50.80	WWWWW-20		
-Y21	2X21	2.000/50.80	2.100/53.34	WWWWW-21		
-Y22	2X22	2.100/53.34	2.200/55.88	WWWWW-22		
-Y23	2X23	2.200/55.88	2.300/58.42	WWWWW-23		
-Y24	2X24	2.300/58.42	2.400/60.96	WWWWW-24		
-Y25	2X25	2.400/60.96	2.500/63.50	WWWWW-25		
-Y26	2X26	2.500/63.50	2.600/66.04	WWWWW-26		
-Y27	2X27	2.600/66.04	2.700/68.58	WWWWW-27		
-Y28	2X28	2.700/68.58	2.800/71.12	WWWWW-28		
-Y29	2X29	2.800/71.12	2.900/73.66	WWWWW-29		
-Y30	2X30	2.900/73.66	3.000/76.20	WWWWW-30		
-Y31	2X31	3.000/76.20	3.100/78.74	WWWWW-31		
-Y32	2X32	3.100/78.74	3.200/81.28	WWWWW-32		
-Y33	2X33	3.200/81.28	3.300/83.82	WWWWW-33		
-Y34	2X34	3.300/83.82	3.400/86.36	WWWWW-34		
-Y35	2X35	3.400/86.36	3.500/88.90	WWWWW-35		
66956-Y36	2X36	3.500/88.90	3.600/91.44	WWWWW-36		NOTE 5,6

mat'l. code	surface ISO 1302	tolerance ISO 406 ISO 1101	projection	product family CARD CONN
ltr ecn no dr date	tolerances unless otherwise specified			title
L	angles	linear	INCH/MM	VERT. CARD CONNECTOR
	0°±2'	J.MUSTARD 1/2/91	scale 4:1	.154/3.91 CTR. DOUBLE ROW
	enrg M.HAHN 1/2/91	chr M.HAHN 1/2/91		dwg no 66956 sheet 3 of 3 size A3
	appd M.HAHN 1/2/91			type Product Customer Drawing
sheet index	revision sheet			

PDM: Rev:L STATUS Released Printed: Oct 13, 2010