

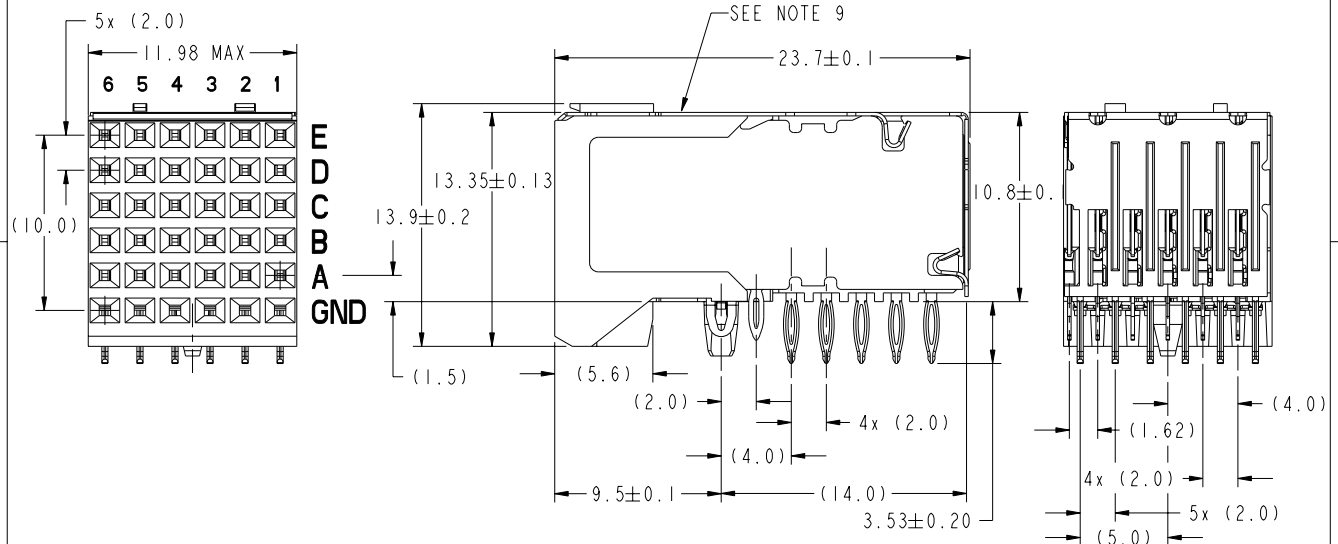

This document is the property of and embodies CONFIDENTIAL and PROPRIETARY information of FCI. No part of the information shown on this document may be used in any way or disclosed to others without the written consent of FCI. Copyright FCI.

PRODUCT NUMBER	PLATING PERFORMANCE LEVEL	PRESS-FIT TAIL PLATING
73981-102	TELCORDIA CO	SnPb
73981-102LF		Sn (SEE NOTE 14)
73981-302	CUSTOMER SPECIAL	SnPb
73981-302LF		Sn (SEE NOTE 14)
73981-902	TELCORDIA CO	SnPb
73981-902LF		Sn (SEE NOTE 14)
73981-902S	CUSTOMER SPECIAL	SnPb
73981-902SLF		Sn (SEE NOTE 14)



mat'l code				tolerances unless otherwise specified		CUSTOMER		FCI	
SEE NOTE 2				0. x ±0.3		COPY		www.fciconnect.com	
ltr	ecm no.	dr	date	linear	0. xx ±0.10	projection		title	
AC	V06-0544	DCH	2006-06-09		0. xxx ±0.050	MM		RIGHT ANGLE SIGNAL RECEPT.	
AD	V07-0352	HTB	2007-06-05	angles	0° ±2°	3:1		5 ROW, 30 POSITION	
AE	V07-0430	DCH	2007-06-27	dr	S. STONER 2000-06-30	scale		product family	
AF	V07-0706	HTB	2007-12-10	enr	W. J. SWAIN 2000-06-14	A		METRAL 1000	
AA	V05-0391	DAI	2005-04-25	chr	W. J. SWAIN 2001-05-21	3:1		size	
AB	V05-0405	DAI	2005-05-16	oppd	W. J. SWAIN 2001-05-21	A		dwg no	
sheet index	revision sheet	AF	AF	AF	AF			code	
		1	2	3	4			213	
								sheet 1 of 4	
								cage code	
								22526	

REV E - 2006-04-18

PDM: Rev:AF STATUS: Released Printed: May 12, 2011



This document is the property of and embodies
 CONFIDENTIAL and PROPRIETARY information of FCJ.
 No part of the information shown on this
 document may be used in any way or disclosed
 to others without the written consent of FCJ.
 Copyright FCJ.

PRODUCT NO.
SEE SHEET 1

PRESS-FIT HOLES		
HOLE DIAMETER AFTER PLATING	$\varnothing 0.65\text{-}\varnothing 0.80$ *	$\varnothing 1.53$
DRILLED HOLE	$\varnothing 0.81\text{-}\varnothing 0.86$ ($\varnothing 0.85$ DRILL)	$\varnothing 1.61\text{-}\varnothing 1.66$ ($\varnothing 1.65$ DRILL)
COPPER PLATING	0.025-0.050	0.025-0.050
SnPb PLATING	0.005-0.015	0.005-0.015

*SEE DRAWINGS 58351 FOR OTHER OPTIONS

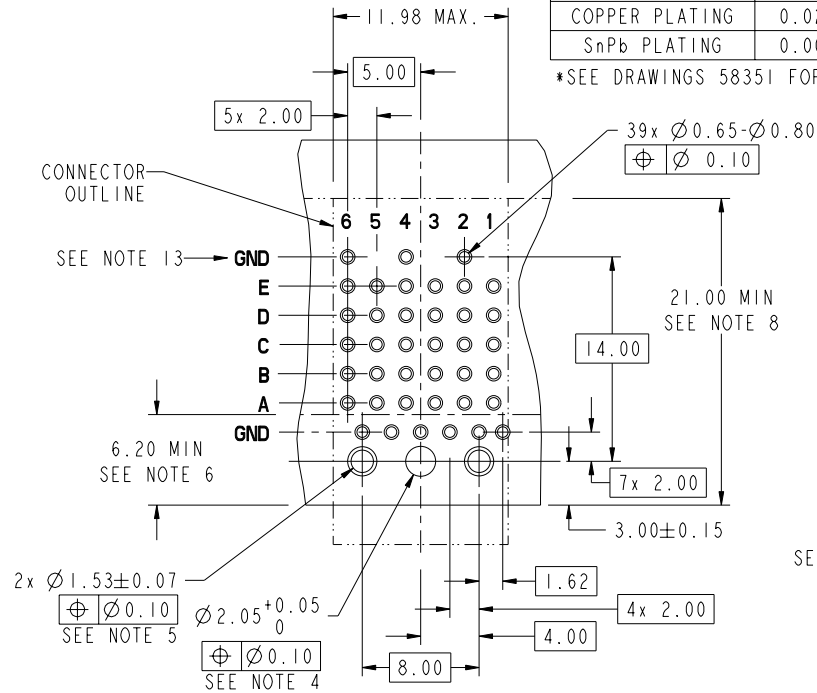

**RECOMMENDED PCB HOLE
PATTERN-COMPONENT SIDE**

mat'l code: SEE NOTE 2		tolerances unless otherwise specified		CUSTOMER	www.fcjconnect.com
lfr	ecm no.	dr	date	COPY	
AF				projection	
				linear	
				angles	0.XXX ±0.050
				dr	$\varnothing \pm 2^\circ$
				engr	S. STONER 2000-06-30
				chr	W. J. SWAIN 2000-06-14
				appd	W. J. SWAIN 2001-05-21
sheet index	revision sheet			scale	1:1
				product family	METRAL 1000
				size	dwg no
					73981
				code	213
					sheet 2
				code code	22526

PDM: Rev:AF STATUS: **Released** Printed: May 12, 2011

1 | 2

3 |

4

PRODUCT NUMBER
SEE SHEET 1

NOTES

1. UNLESS OTHERWISE SPECIFIED ALL DIMENSIONS AND TOLERANCES ARE IN ACCORDANCE WITH ASME Y14.5M, 1994
2. HOUSING MATERIAL: LIQUID CRYSTAL POLYMER, GLASS FILLED, FLAME RETARDANT PER UL94V-0
GROUND SHIELD MATERIAL: COPPER ALLOY
SIGNAL CONTACT MATERIAL: COPPER ALLOY
3. PLATING ON PRESS-FIT TAIL AREA: 73981-X02 IS SnPb, 73981-X02LF IS Sn (LEAD FREE)
4. $\varnothing 2.05$ HOLE IS UNPLATED
5. $\varnothing 1.53$ PLATED HOLES (2X) ARE FOR GROUNDS
6. AVOID TRACES IN THIS AREA ON TOP OF PCB DUE TO EXPOSED GROUND SHIELD
7. UNDERPLATING FOR SHIELD AND SIGNAL CONTACTS IS 1.3 μ m Ni MIN
8. COMPONENT KEEP OUT ZONE FOR PRESS BLOCK CLEARANCE.
9. PRODUCT MARKING: PRODUCT NUMBER, DATE AND LOT CODE.
10. SEE GS-20-017 FOR APPLICATION OF CONNECTOR TO PCB.
11. PCB THICKNESS RANGE: 1.3mm TO 2.5mm
12. SEE PRODUCT SPECIFICATION GS-12-110 FOR PRODUCT PERFORMANCE CHARACTERISTICS.
13. THIS GROUND ROW OF VIA-HOLES ONLY REQUIRED FOR PREVIOUS REVISIONS OF THIS DESIGN WHERE THE TOP SHIELDS HAD EON PRESS-FIT. DUE TO INVENTORIES OF PREVIOUS VERSION WE RECOMMEND THEY BE DESIGNED IN.
14. THE PRODUCTS WHERE THE PART NUMBER ENDS IN LF MEET EUROPEAN DIRECTIVES AND OTHER COUNTRY REGULATIONS AS DESCRIBED IN GS-22-008. ALL PRODUCTS WILL WITHSTAND EXPOSURE TO 260° FOR 60 SECONDS IN A CONVECTION, INFRA-RED OR VAPOR PHASE REFLOW OVEN.

A

A



This document is the property of and embodies CONFIDENTIAL and PROPRIETARY information of FCI. No part of the information shown on this document may be used in any way or disclosed to others without the written consent of FCI. Copyright FCI.

B

B

mat'l code SEE NOTE 2				tolerances unless otherwise specified		CUSTOMER		FCI www.fciconnect.com	
ltr	ecm no.	dr	date	linear	0.X ±0.3	COPY		title	
AF					0.XX ±0.10	projection		RIGHT ANGLE SIGNAL RECEPT. 5 ROW, 30 POSITION	
				angles	0.XXX ±0.050			product family METRAL 1000 code	
				dr	0° ±2°			size dwg no	
				eng	S. STONER 2000-06-30	scale		73981	
				chr	W. J. SWAIN 2000-06-14	3:1		sheet	
				oppd	W. J. SWAIN 2001-05-21	A		3	
sheet index	revision sheet								

1 | 2

3 |

4

Pro/E

cage code 22526

PDM: Rev:AF

STATUS: Released

Printed: May 12, 2011

PRODUCT NUMBER
SEE SHEET 1

DISTANCE FROM CONTACT POINT TO BOARD	
CONTACT	DISTANCE
A	12.5
B	16.2
C	19.5
D	22.3
E	25.2

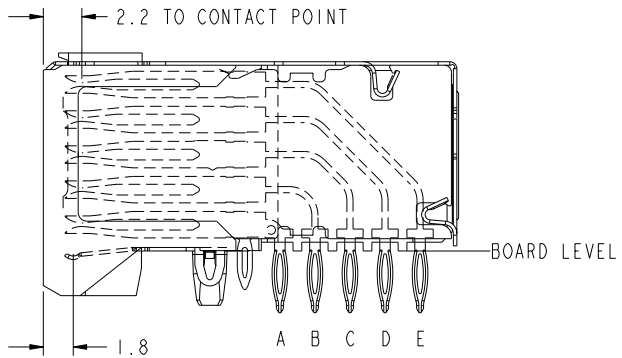

CONTACT POINT AND SKEW

mat'l code		SEE NOTE 2		tolerances unless otherwise specified		CUSTOMER		FCJ		www.fcjconnect.com	
lfr	ecm no.	dr	date	linear	0.X ±0.3	projection	COPY	title	RIGHT ANGLE SIGNAL RECEPT. 5 ROW, 30 POSITION		
AF					0.XX ±0.10						
				angles	0.XXX ±0.050			product family	METRAL 1000		code
				dr	S. STONER 2000-06-30	MM		size	dwg no		213
				engr	W. J. SWAIN 2000-06-14	scale		A	73981		sheet
				chr	W. J. SWAIN 2001-05-21	3:1					4
				oppd	W. J. SWAIN 2001-05-21						
sheet index	revision sheet								cage code		22526



This document is the property of and embodies CONFIDENTIAL and PROPRIETARY information of FCJ. No part of the information shown on this document may be used in any way or disclosed to others without the written consent of FCJ. Copyright FCJ.

REV E - 2006-04-18