

# Cable Terminations

ONLINE  
CATALOG

AEP cable terminations are a low-cost solution for applications which require a signal or cable core to be fed through a panel or into a P.C. board, but do not need the option of disconnecting the cable. In these cases, a cable termination provides a method of securely anchoring and grounding the cable. The use of a cable termination also saves the expense using a pair of connectors.

Both crimp and clamp types for flexible cable grip the cable braid with a force greater than the breaking strength of the braid.

For greater space savings see the line of microminiature P.C. board terminations on page 28 of our [SSMB/SSLB/SSMC Microminiature Connectors](#) online catalog.

## Contents

<b>Bulkhead Mounted Cable Terminations</b> . . . . .	<b>2</b>
<b>Bulkhead Mounted Cable Feedthroughs</b> . . . . .	<b>3</b>
<b>P.C. Board Cable Terminations</b> . . . . .	<b>4</b>
<b>Assembly Instructions</b> . . . . .	<b>5</b>
<b>Mounting Dimensions</b> . . . . .	<b>8</b>
<b>Assembly Tooling</b> . . . . .	<b>8</b>
<b>Index by part number</b> . . . . .	<b>8</b>

## Cable Attachment Methods

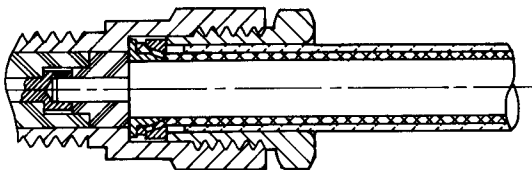

### **Clamp Type For Flexible Cable**

These connectors can be assembled without special tooling, and are field replaceable. They provide metal-to-metal clamping of the cable braid.

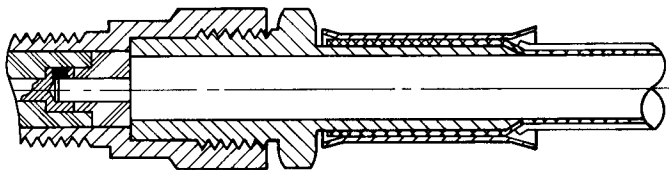

### **Crimp Type For Flexible Cable**

Crimping the cable braid is the most reliable and repeatable method of cable assembly, and provides support for the cable during flexure. AEP crimp type connectors are assembled quickly and easily using readily-available commercial or MIL crimp tools.

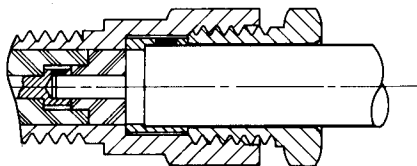

### **Solder-Clamp For Semi-Rigid Cable**

This method allows retrimming of the cable dielectric, if necessary, during assembly. Connectors can be repositioned relative to the cable after assembly by loosening the clamp nut. Solder-clamp connectors are field replaceable without special tools.



# Bulkhead Mounted Cable Terminations

Click on part number to go directly to cable assembly instructions

## Straight Terminations

### Bulkhead Mounted Straight Cable Termination

Clamp type for flexible cable:

8020-1551-0XX (Gold plated)

8020-7551-0XX (Nickel plated)

Solder-clamp for semi-rigid cable:

8020-1541-0XX (Gold plated)

8020-7541-0XX (Nickel plated)

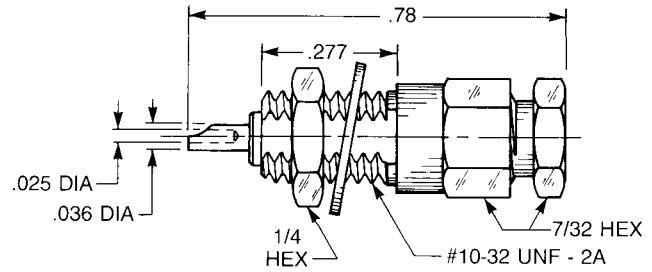

### Bulkhead Mounted Straight Cable Termination

Crimp type for flexible cable:

8020-1571-0XX (Gold plated)

8020-7571-0XX (Nickel plated)

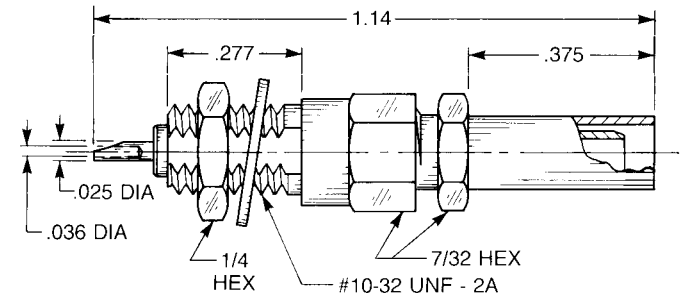

## Right Angle Terminations

### Bulkhead Mounted Right Angle Cable Termination

Clamp type for flexible cable:

8044-1551-0XX (Gold plated)

8044-7551-0XX (Nickel plated)

Solder-clamp for semi-rigid cable:

8044-1541-0XX (Gold plated)

8044-7541-0XX (Nickel plated)

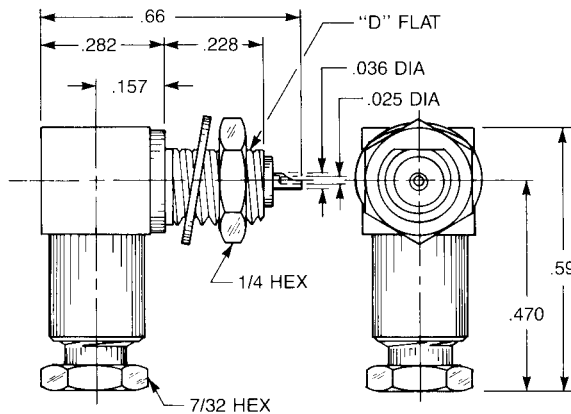

### Bulkhead Mounted Right Angle Cable Termination

Crimp type for flexible cable:

8144-1521-0XX (Gold plated)

8144-7521-0XX (Nickel plated)

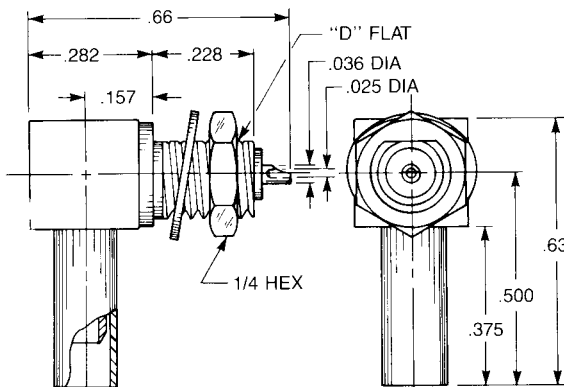

Substitute the appropriate cable group number for "XX" when ordering:

GROUP	CABLE TYPES	GROUP	CABLE TYPES	GROUP	CABLE TYPES
02	RG178, RG196, M17/93, M17/169	05	RG178DS, RG196DS	10	.085" semi-rigid, RG405, M17/133
03	RG174, RG179, RG316, M17/113, M17/119, M17/172, M17/189	09	.141" semi-rigid, RG 402M17/130	19	RG174DS, RG316DS, M17/151, M17/152, Times RD-316



APPLIED ENGINEERING PRODUCTS

(203) 776-2813 • FAX (203) 776-8294

www.aepconnectors.com • aepsales@aepconnectors.com

# Bulkhead Mounted Cable Feedthroughs

Click on part number to go directly to cable assembly instructions

## Straight Feedthroughs

### Bulkhead Mounted Straight Cable Feedthrough

- Feeds cable dielectric and center conductor through bulkhead

Clamp type for flexible cable:

**8021-1051-0XX** (Gold plated)

**8021-7051-0XX** (Nickel plated)

Solder-clamp for semi-rigid cable:

**8021-1041-0XX** (Gold plated)

**8021-7041-0XX** (Nickel plated)

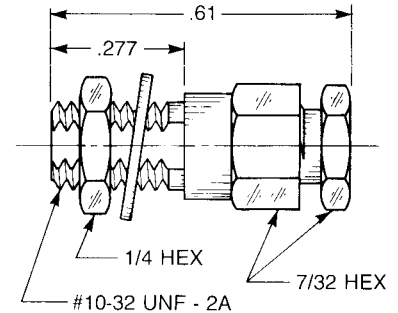

### Bulkhead Mounted Straight Cable Feedthrough

- Feeds cable dielectric and center conductor through bulkhead

Crimp type for flexible cable:

**8021-1071-0XX** (Gold plated)

**8021-7071-0XX** (Nickel plated)

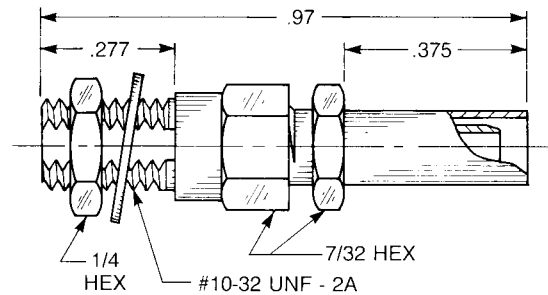

Substitute the appropriate cable group number for "XX" when ordering:

GROUP	CABLE TYPES	GROUP	CABLE TYPES	GROUP	CABLE TYPES
02	RG178, RG196, M17/93, M17/169	05	RG178DS, RG196DS	10	.085" semi-rigid, RG405, M17/133
03	RG174, RG179, RG316, M17/113, M17/119, M17/172, M17/189	09	.141" semi-rigid, RG 402M17/130	19	RG174DS, RG316DS, M17/151, M17/152, Times RD-316



APPLIED ENGINEERING PRODUCTS

(203) 776-2813 • FAX (203) 776-8294

www.aepconnectors.com • aepsales@aepconnectors.com

# P.C. Board Mounted Cable Terminations

Click on part number to go directly to cable assembly instructions

## Straight Terminations

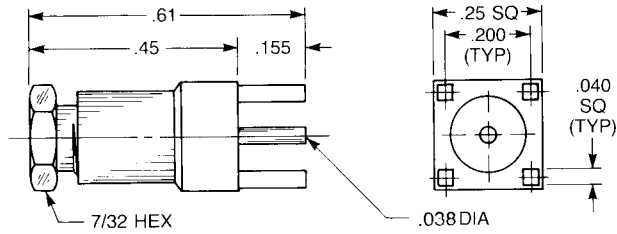

### Straight P.C. Board Cable Termination

Clamp type for flexible cable:

**8046-1551-0XX** (Gold plated)

**8046-7551-0XX** (Nickel plated)

Solder-clamp for semi-rigid cable:

**8046-1541-0XX** (Gold plated)

**8046-7541-0XX** (Nickel plated)

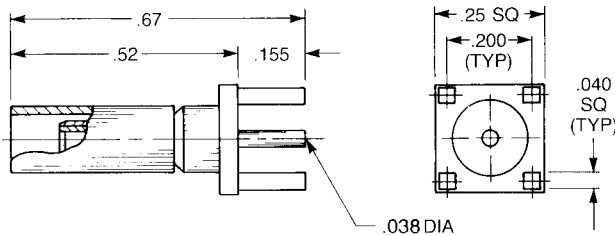

### Straight P.C. Board Cable Termination

Crimp type for flexible cable:

**8146-1521-0XX** (Gold plated)

**8146-7521-0XX** (Nickel plated)

## Right Angle Terminations

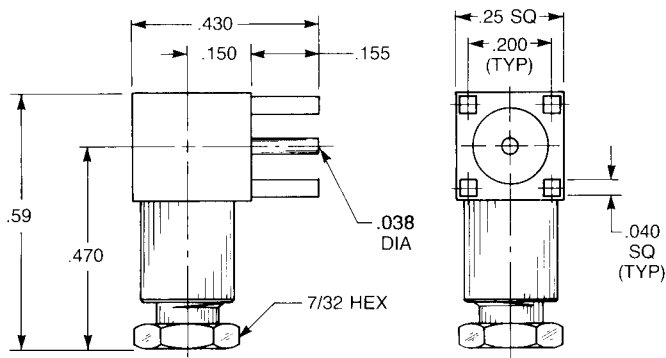

### Right Angle P.C. Board Cable Termination

Clamp type for flexible cable:

**8045-1551-0XX** (Gold plated)

**8045-7551-0XX** (Nickel plated)

Solder-clamp for semi-rigid cable:

**8045-1541-0XX** (Gold plated)

**8045-7541-0XX** (Nickel plated)

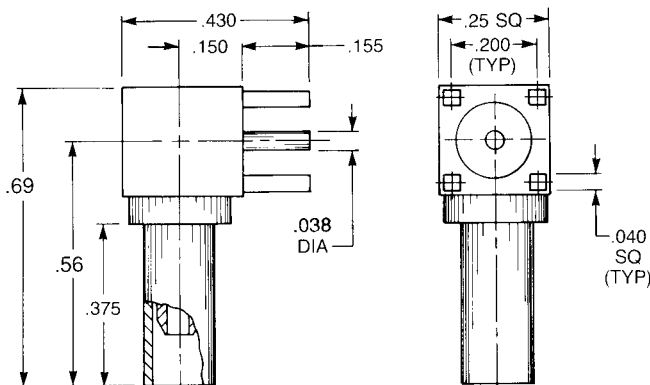

### Right Angle P.C. Board Cable Termination

Crimp type for flexible cable:

**8145-1521-0XX** (Gold plated)

**8145-7521-0XX** (Nickel plated)

Substitute the appropriate cable group number for "XX" when ordering:

GROUP	CABLE TYPES	GROUP	CABLE TYPES	GROUP	CABLE TYPES
02	RG178, RG196, M17/93, M17/169	05	RG178DS, RG196DS	10	.085" semi-rigid, RG405, M17/133
03	RG174, RG179, RG316, M17/113, M17/119, M17/172, M17/189	09	.141" semi-rigid, RG 402M17/130	19	RG174DS, RG316DS, M17/151, M17/152, Times RD-316

# Cable Assembly Instructions

## Clamp type terminations for flexible cable

Note: for cable feedthroughs, trim dielectric and center conductor per application requirements.

### Straight Connectors—Flexible Cable

#### Parts list

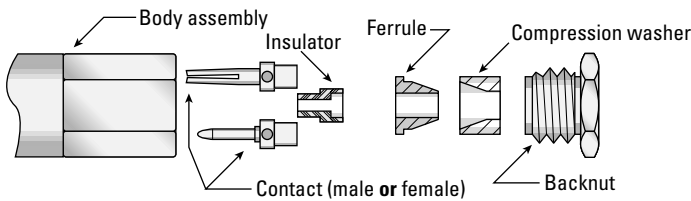

1

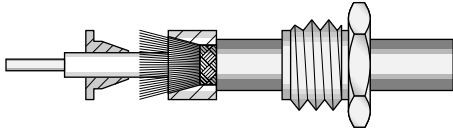

- Trim cable per trim code below; tin end of center conductor.
- Slide backnut onto cable. Slide compression washer onto cable in the orientation shown until it stops against cable jacket.
- Flare cable braid by rotating dielectric and slide ferrule under braid.

2

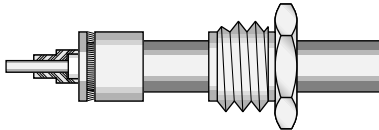

- Press ferrule against compression washer.
- Trim excess braid flush with outer diameter of compression washer and ferrule.
- Assemble insulator over cable center conductor and dielectric.

3

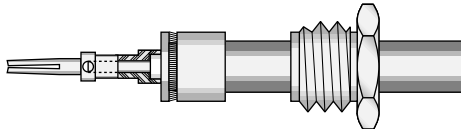

- Assemble contact onto cable center conductor.
- Solder contact to center conductor by heating rear of contact (do not feed additional solder through inspection hole in contact).

4

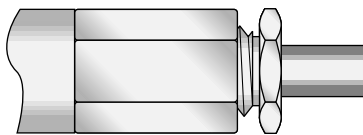

- Insert cable assembly into body assembly. Tighten to 90–100 inch-ounces torque. (Hold cable/hardware assembly stationary and rotate body when tightening.)

### Cable Trim Dimensions

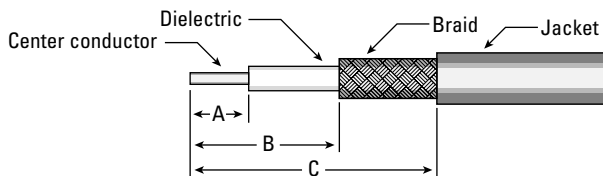

CONNECTOR TYPE	A	B	C
STRAIGHT CONNECTORS	.080	.120	.240
RIGHT ANGLE CONNECTORS	.080	.180	.300

### Right Angle Connectors—Flexible Cable

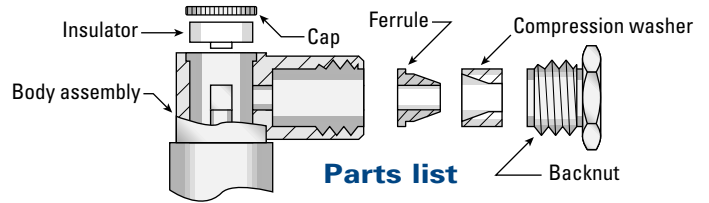

1

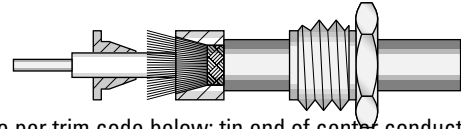

- Trim cable per trim code below; tin end of center conductor.
- Slide backnut onto cable. Slide compression washer onto cable in the orientation shown until it stops against cable jacket.
- Flare cable braid by rotating dielectric and slide ferrule under braid.

2

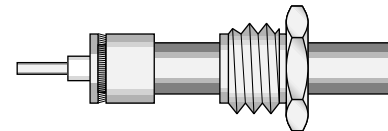

- Press ferrule against compression washer.
- Trim excess braid flush with outer diameter of compression washer and ferrule.
- Assemble insulator over cable center conductor and dielectric.

3

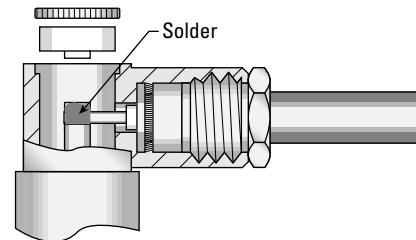

- Insert cable assembly into body assembly. Tighten to 90–100 inch-ounces torque. (Hold cable/hardware assembly stationary and rotate body when tightening.)
- Solder center conductor into notch in rear of contact with .025–.032" diameter chisel-tip soldering iron.
- Solder should cover center conductor, but not extend over top of notch in contact, or exceed contact diameter.

4

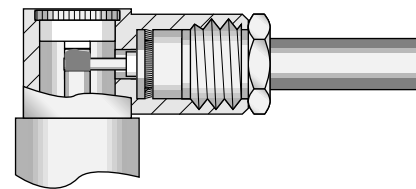

- Place insulator in body cavity, and press cap into place. Properly assembled cap will be slightly below end of body assembly.



APPLIED ENGINEERING PRODUCTS

(203) 776-2813 • FAX (203) 776-8294

www.aepconnectors.com • aepsales@aepconnectors.com

# Cable Assembly Instructions

## Crimp type terminations for flexible cable

Note: for cable feedthroughs, trim dielectric and center conductor per application requirements.

### Straight Connectors—Flexible Cable

#### Parts list

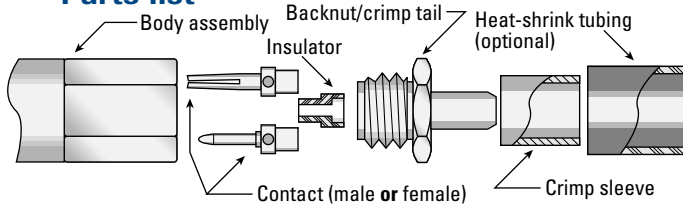

**1**

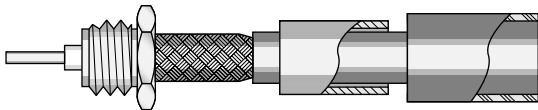

- Trim cable per trim code below; tin end of center conductor.
- Slide heat-shrink tubing and crimp sleeve over cable.
- Flare cable braid by rotating dielectric and slide cable into crimp tail.

**2**

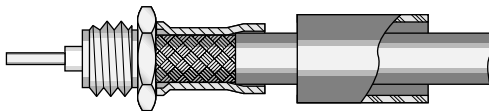

- Position cable so braid touches rear of back nut.
- Slide crimp sleeve forward to touch rear of back nut.
- Crimp braid with appropriate die size from chart below.

**3**

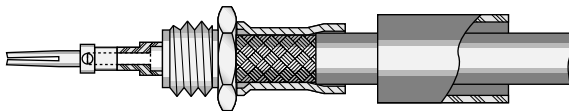

- Assemble insulator and contact onto cable dielectric and center conductor.
- Solder contact to center conductor by heating rear of contact (do not feed additional solder through inspection hole in contact).

**4**

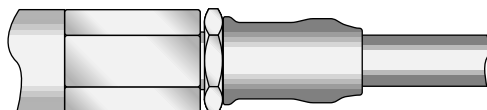

- Insert cable assembly into body assembly. Tighten to 90–100 inch-ounces torque. (Hold cable/hardware assembly stationary and rotate body when tightening.)
- Slide shrink tubing over crimp sleeve and shrink to fit.

### Cable Trim Dimensions

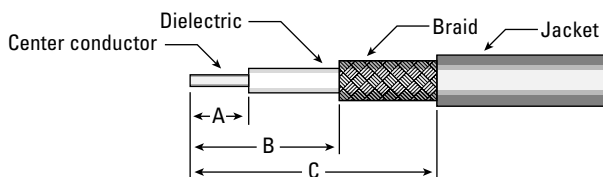

CONNECTOR TYPE	A	B	C
STRAIGHT CONNECTORS	.100	.430	.700
RIGHT ANGLE CONNECTORS	.070	.200	.450

### Right Angle Connectors—Flexible Cable

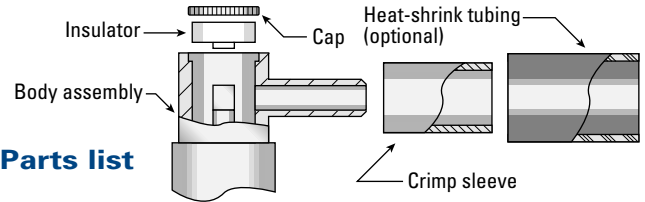

**1**

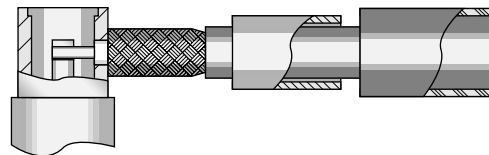

- Trim cable per trim code below; tin end of center conductor.
- Slide heat-shrink tubing and crimp sleeve over cable.
- Flare cable braid by rotating dielectric and slide cable into crimp tail.

**2**

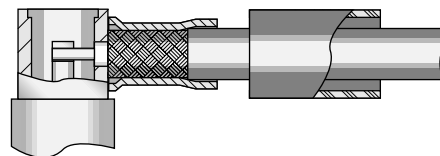

- Position cable so braid touches rear of body assembly.
- Slide crimp sleeve forward to touch rear of body assembly.
- Crimp braid with appropriate die size from chart below.

**3**

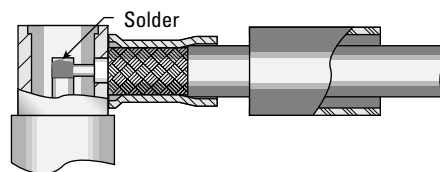

- Solder center conductor into notch in rear of contact with .025–.032" diameter chisel-tip soldering iron.
- Solder should cover center conductor, but not extend over top of notch in contact, or exceed contact diameter.

**4**

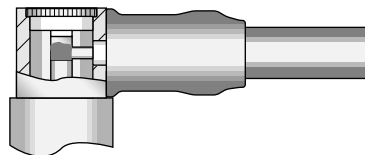

- Place insulator in body cavity, and press cap into place. Properly assembled cap will be slightly below end of body assembly.
- Slide shrink tubing over crimp sleeve and shrink to fit.

### Crimp Die Sizes

CABLE GROUP	HEX DIE SIZE
02	.105
03	.128
05	.128
19	.128



APPLIED ENGINEERING PRODUCTS

(203) 776-2813 • FAX (203) 776-8294

www.aepconnectors.com • aepsales@aepconnectors.com

# Cable Assembly Instructions

## Solder-clamp terminations for semi-rigid cable

Note: for cable feedthroughs, trim dielectric and center conductor per application requirements.

### Straight Connectors—Semi-Rigid Cable

#### Parts list

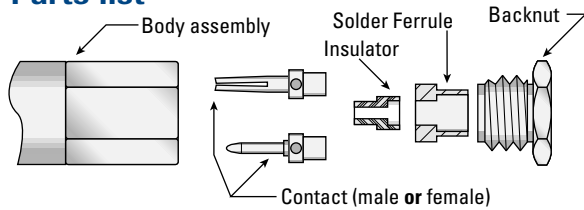

**1**

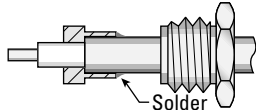

- Trim cable per trim code below; tin end of center conductor.
- Slide backnut over cable. Slide solder ferrule over cable until it stops against cable jacket.
- Solder cable jacket to ferrule.

**2**

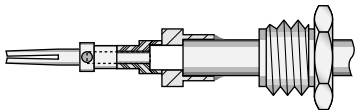

- Assemble insulator and contact onto cable dielectric and center conductor. If insulator is not flush against solder ferrule due to dielectric extrusion, retrim dielectric.
- Solder contact to center conductor by heating rear of contact (do not feed additional solder through inspection hole in contact).

**3**

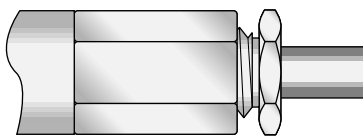

- Insert cable assembly into body assembly. Tighten to 90–100 inch-ounces torque. (Hold cable/hardware assembly stationary and rotate body when tightening.)

### Right Angle Connectors—Semi-Rigid Cable

#### Parts list

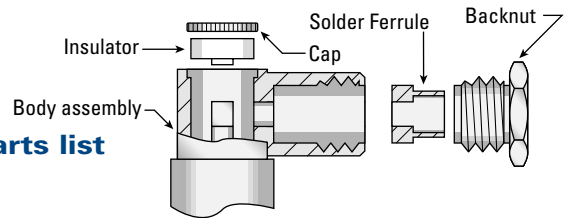

**1**

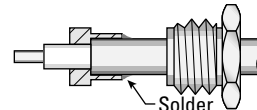

- Trim cable per trim code below; tin end of center conductor.
- Slide backnut over cable. Slide solder ferrule over cable until it stops against cable jacket.
- Solder cable jacket to ferrule.

**2**

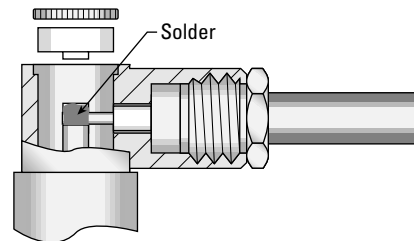

- Insert cable assembly into body assembly. Tighten to 90–100 inch-ounces torque. (Hold cable/hardware assembly stationary and rotate body when tightening.)
- Solder center conductor into notch in rear of contact with .025–.032" diameter chisel-tip soldering iron.
- Solder should cover center conductor, but not extend over top of notch in contact, or exceed contact diameter.

**3**

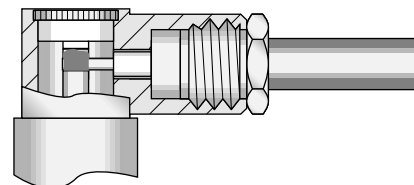

- Place insulator in body cavity, and press cap into place. Properly assembled cap will be slightly below end of body assembly.

### Cable Trim Dimensions

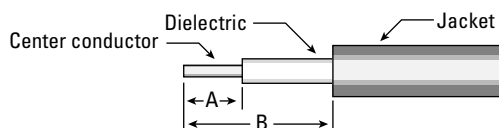

CONNECTOR TYPE	A	B
STRAIGHT CONNECTORS— <b>.085"</b> cable	<b>.090</b>	<b>.170</b>
STRAIGHT CONNECTORS— <b>.141"</b> cable	<b>.105</b>	<b>.130</b>
RIGHT ANGLE CONNECTORS	<b>.110</b>	<b>.150</b>



# Mounting Dimensions

## Bulkhead Terminations

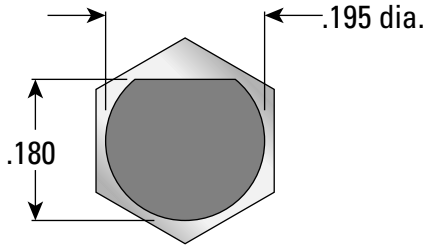

Flat of mounting surface is aligned with body hex as shown.

## P.C. Board Terminations

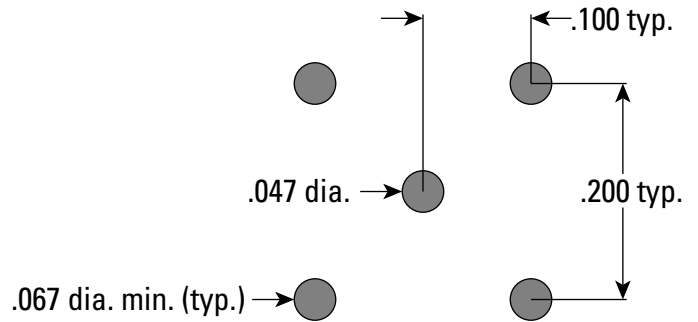

# Assembly Tooling

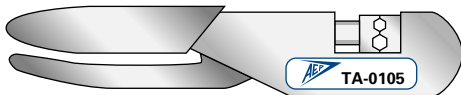

DESCRIPTION	AEP P/N
Crimp tool with .105" and .128" hex dies	TA-0105



DESCRIPTION	AEP P/N
Torque wrench with 7/32" jaws for cable termination backnuts; 95 inch-ounces torque	TA-0436

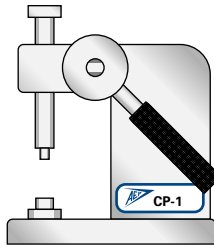

DESCRIPTION	AEP P/N
Capping tool (arbor press) with base for SMB right angle plugs and cable terminations	CP-1

# Index by Part Number

Click on any line below to go directly to the appropriate page

P/N	Page	P/N	Page
8020-1541-0XX	2	8044-7551-0XX	2
8020-1551-0XX	2	8045-1541-0XX	4
8020-1571-0XX	2	8045-1551-0XX	4
8020-7541-0XX	2	8045-7541-0XX	4
8020-7551-0XX	2	8045-7551-0XX	4
8020-7571-0XX	2	8046-1541-0XX	4
8021-1041-0XX	3	8046-1551-0XX	4
8021-1051-0XX	3	8046-7541-0XX	4
8021-1071-0XX	3	8046-7551-0XX	4
8021-7041-0XX	3	8144-1521-0XX	2
8021-7051-0XX	3	8144-7521-0XX	2
8021-7071-0XX	3	8145-1521-0XX	4
8044-1541-0XX	2	8146-1521-0XX	4
8044-1551-0XX	2	8146-7521-0XX	4
8044-7541-0XX	2		