

CONNECTOR DESIGNATORS
A-B*-C-D-E-F
G-H-J-K-L-S

* Conn. Desig. B See Note 5
DIRECT COUPLING

TYPE B INDIVIDUAL AND/OR OVERALL SHIELD TERMINATION

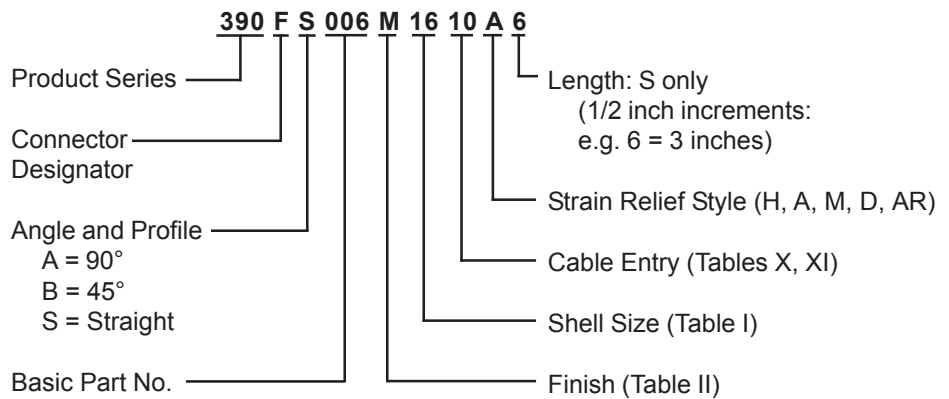

Length ± .060 (1.52)
 Min. Order Length 2.0 Inch
 (See Note 4)

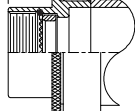

STYLE 2 (STRAIGHT)
 See Note 1)

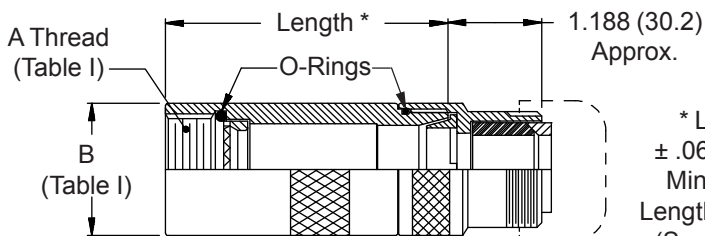

* Length ± .060 (1.52)
 Min. Order Length 1.5 Inch
 (See Note 4)

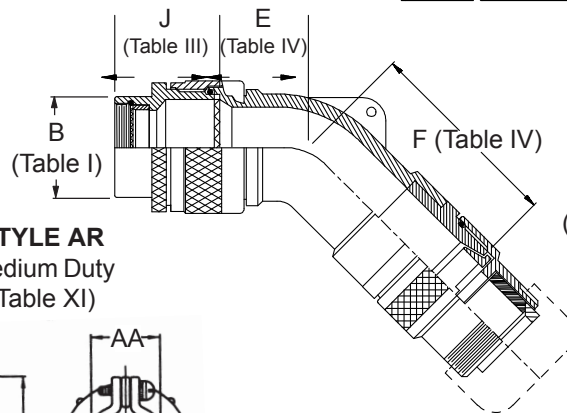

STYLE AR
 Medium Duty
 (Table XI)

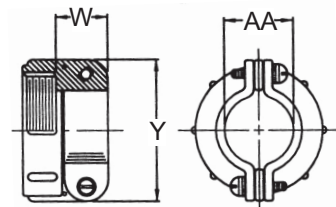
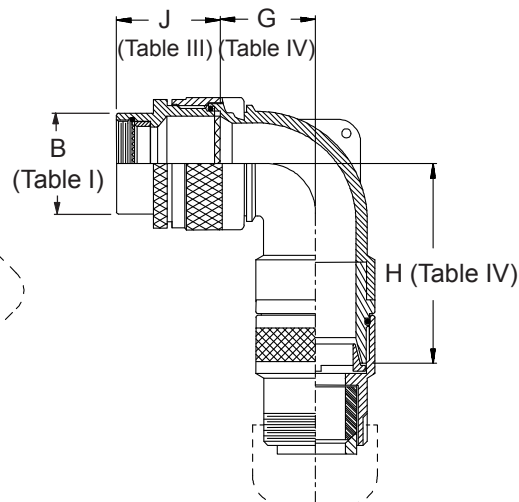

STYLE H
 Heavy Duty
 (Table X)

STYLE A
 Medium Duty
 (Table XI)

STYLE M
 Medium Duty
 (Table XI)

STYLE D
 Medium Duty
 (Table XI)

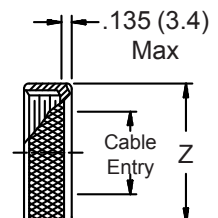
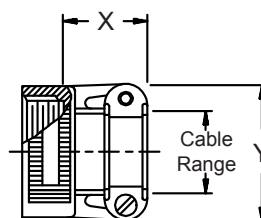
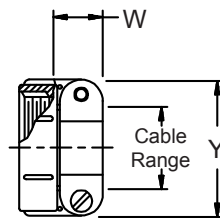
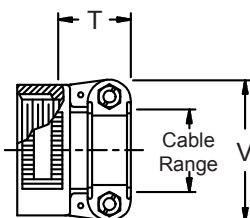

390-006
Submersible EMI/RFI Cable Sealing Backshell
 with Strain Relief
 Type B - Direct Coupling - Low Profile



See inside back cover fold-out or pages 13 and 14 for Tables I and II.

TABLE III: FRONT ADAPTER			
Shell Size	J Max - Conn. Designator		
	A-E-F		C
	J-H-L-S	D-B-G-K	
08/09	1.180 (30.0)	1.440 (36.6)	
10/11	1.180 (30.0)	1.440 (36.6)	
12/13	1.180 (30.0)	1.440 (36.6)	1.735 (44.1)
14/15	1.180 (30.0)	1.440 (36.6)	1.915 (48.6)
16/17	1.380 (35.0)	1.560 (39.6)	1.915 (48.6)
18/19	1.380 (35.0)	1.560 (39.6)	1.915 (48.6)
20/21	1.380 (35.0)	1.560 (39.6)	1.915 (48.6)
22/23	1.380 (35.0)	1.560 (39.6)	1.915 (48.6)
24/25	1.380 (35.0)	1.560 (39.6)	1.915 (48.6)
28/29	1.610 (40.9)	1.560 (39.6)	1.915 (48.6)
32/33	1.610 (40.9)	1.750 (44.5)	1.915 (48.6)
36	1.610 (40.9)	1.750 (44.5)	1.915 (48.6)
40	1.610 (40.9)	2.190 (55.6)	1.915 (48.6)

TABLE IV: ELBOW DIMENSIONS							
Dash No.	E Max	F Max	G Max	H Max			
04	.630 (16.0)	2.601 (66.1)	.636 (16.2)	2.551 (64.8)			
06	.630 (16.0)	2.601 (66.1)	.710 (18.0)	2.671 (67.8)			
08	.692 (17.6)	2.661 (67.6)	.731 (18.6)	2.691 (68.4)			
10	.755 (19.2)	3.091 (78.5)	.825 (21.0)	3.101 (78.8)			
12	.848 (21.5)	3.201 (81.3)	.988 (25.1)	3.191 (81.1)			
16	1.036 (26.3)	3.391 (86.1)	1.087 (27.6)	3.361 (85.4)			
20	1.130 (28.7)	3.604 (91.5)	1.325 (33.7)	3.534 (89.8)			
24	1.255 (31.9)	3.637 (92.4)	1.337 (34.0)	3.687 (93.6)			
28	1.317 (33.5)	3.737 (94.9)	1.827 (46.4)	3.937 (100.0)			
32	1.348 (34.2)	3.877 (98.5)	2.027 (51.5)	3.987 (101.3)			

TABLE X: CABLE ENTRY					
Dash No.	T Max	V Max	Cable Range		
			Min	Max	
04	.780 (19.8)	.957 (24.3)	.125 (3.2)	.312 (7.9)	
06	.780 (19.8)	1.145 (29.1)	.250 (6.4)	.437 (11.1)	
08	.780 (19.8)	1.332 (33.8)	.387 (9.8)	.562 (14.3)	
10	.780 (19.8)	1.332 (33.8)	.350 (8.9)	.625 (15.9)	
12	.811 (20.6)	1.551 (39.4)	.500 (12.7)	.750 (19.1)	
16	.905 (23.0)	1.770 (45.0)	.625 (15.9)	.937 (23.8)	
20	1.092 (27.7)	2.113 (53.7)	.875 (22.2)	1.250 (31.8)	
24	1.124 (28.5)	2.363 (60.0)	1.000 (25.4)	1.375 (34.9)	
28	1.399 (35.5)	2.770 (70.4)	1.250 (31.8)	1.625 (41.3)	
32	1.399 (35.5)	3.020 (76.7)	1.437 (36.5)	1.875 (47.6)	

1. When maximum cable entry (page 22) is exceeded, Style 2 will be supplied. (Function S only).
2. Metric dimensions (mm) are indicated in parentheses.
3. Cable range is defined as the accommodations range for the wire bundle or cable. Dimensions shown are not intended for inspection criteria.
4. Consult factory for shorter lengths on straight backshells.
5. When using Connector Designator B refer to pages 18 and 19 for part number development.

TABLE XI: CABLE ENTRY									
Dash No.	W Max	X Max	Y Max	Z Max	AA*** Closed	Cable Range			
						Min**	Max		
04*	.437 (11.1)	.760 (19.3)	.906 (23.0)	.755 (19.2)	.312 (7.9)	.188 (4.8)	.312 (7.9)		
06*	.500 (12.7)	.760 (19.3)	1.093 (27.8)	.942 (23.9)	.438 (11.1)	.281 (7.1)	.438 (11.1)		
08	.563 (14.3)	.760 (19.3)	1.187 (30.1)	1.067 (27.1)	.562 (14.3)	.387 (9.8)	.562 (14.3)		
10	.563 (14.3)	.760 (19.3)	1.281 (32.5)	1.192 (30.3)	.625 (15.9)	.375 (9.5)	.625 (15.9)		
12	.563 (14.3)	.760 (19.3)	1.500 (38.1)	1.380 (35.1)	.750 (19.1)	.438 (11.1)	.750 (19.1)		
16	.656 (16.7)	1.073 (27.3)	1.719 (43.7)	1.535 (39.0)	.938 (23.8)	.625 (15.9)	.938 (23.8)		
20	.656 (16.7)	1.323 (33.6)	2.062 (52.4)	1.848 (46.9)	1.250 (31.8)	.875 (22.2)	1.250 (31.8)		
24	.656 (16.7)	1.323 (33.6)	2.312 (58.7)	2.255 (57.3)	1.375 (34.9)	1.000 (25.4)	1.375 (34.9)		
28	1.188 (30.2)	1.572 (39.9)	2.719 (69.1)	2.505 (63.6)	1.625 (41.3)	1.250 (31.8)	1.625 (41.3)		
32*	1.187 (30.1)	1.572 (39.9)	2.969 (75.4)	2.755 (70.0)	1.875 (47.6)	1.437 (36.5)	1.875 (47.6)		

* Not available in Style M clamp. ** Not Applicable Style D ***Applicable Style AR Only.