

3M™ 4-Wall, Tripolarized Header

.050" × .100" Latch/Ejector, PTH & SMT Straight, PTH Right Angle

810 Series



- Tripolarized for robust alignment when mating to 820 series socket
- 50 mil × 100 mil halves the connector length vs. traditional 100 mil x 100 mil products
- Latching Ejector for rugged high performance applications
- Available for through hole or surfacemount attachment
- High temperature plastic for lead free surfacemount or Paste-in-Hole soldering methods
- Four-wall shroud provides contact protection
- Contacts: 20, 26, 36, 40, 50, 60, 68, 80 and 100
- See the Regulatory Information Appendix (RIA) in the "RoHS compliance" section of www.3Mconnector.com for compliance information

Date Modified: January 11, 2011

TS-0253-G
Sheet 1 of 7

Physical

Insulation:

Material: High Temperature Plastic (LCP)

Flammability: UL 94V-0

Color: Black (RB Plating only) or Natural

Contact:

Material: Copper Alloy

Plating:

Underplating: 100 μ" [2.54 mm] Nickel

Wiping Area: 30 μ" [0.76 mm] Gold

Solder Tails: Matte Tin or Tin Lead (See Ordering Information)

Marking: 3M Logo, Part Number and Orientation Triangle

Mating Compatibility: 820 Series (TS-0254)

Electrical

Current Rating: 3.00 A, 1 Contact Powered
2.00 A, 4 Contacts Powered
0.75 A, All Contacts powered

Rating Conditions: EIA-364-070 Method 2, 30 degrees C maximum temperature rise, 20% derated. Reference appropriate 3M Product Specification for detailed current derating curves.

Insulation Resistance: $> 1 \times 10^9 \Omega$ at 500 V_{DC}

Withstanding Voltage: 500 V_{RMS} at Sea Level

Environmental

Temperature Rating: -55°C to +105°C

Process Rating: Maximum 260°C (Profile per J-STD-020C)

Moisture Sensitivity Level: 1 (per J-STD-020C)

UL File No.: E68080

3M
Electronic Solutions Division
Interconnect Solutions
<http://www.3Mconnector.com>

3M is a trademark of 3M Company.
For technical, sales or ordering information call
800-225-5373

3M™ 4-Wall, Tripolarized Header

.050" × .100" Latch/Ejector, PTH & SMT Straight, PTH Right Angle

810 Series



Inch [Imm]			
Tolerance Unless Noted			
	.0	.00	.000
Inch	±.1	±.01	±.005

[] Dimensions for Reference Only

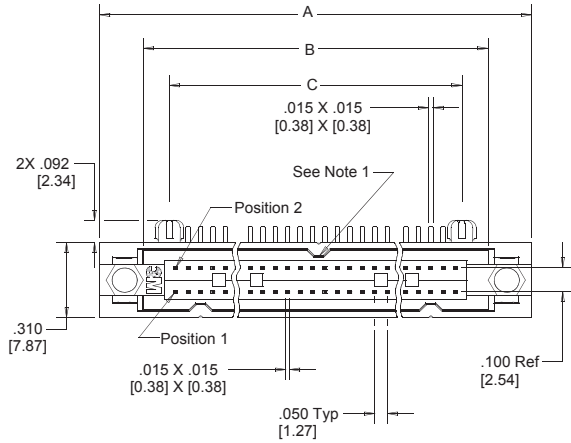

Contact Quantity	Dimensions				
	A	B	C	D Short (Ref.)	D Long (Ref.)
020	1.060 [26.92]	0.722 [18.34]	0.500 [12.70]	1.671 [42.44]	1.842 [46.79]
026	1.210 [30.73]	0.872 [22.15]	0.650 [16.51]	1.821 [46.25]	1.992 [50.60]
036	1.460 [37.08]	1.122 [28.50]	0.900 [22.86]	2.071 [52.60]	2.242 [56.95]
040	1.560 [39.62]	1.222 [31.04]	1.000 [25.40]	2.171 [55.14]	2.342 [59.49]
050	1.810 [45.97]	1.472 [37.39]	1.250 [31.75]	2.421 [61.49]	2.592 [65.84]
060	2.060 [52.32]	1.722 [43.74]	1.500 [38.10]	2.671 [67.84]	2.842 [72.19]
068	2.260 [57.40]	1.922 [48.82]	1.700 [43.18]	2.871 [72.92]	3.042 [77.27]
080	2.560 [65.02]	2.222 [56.44]	2.000 [50.80]	3.171 [80.54]	3.342 [84.89]
100	3.060 [77.72]	2.722 [69.14]	2.500 [63.50]	3.671 [93.24]	3.842 [97.59]

PCB Thickness	"F" Solder Tail Length ± .010
.062 [1.57]	.090 [2.29]
.094 [2.39]	.112 [2.84]
.125 [3.18]	.143 [3.63]

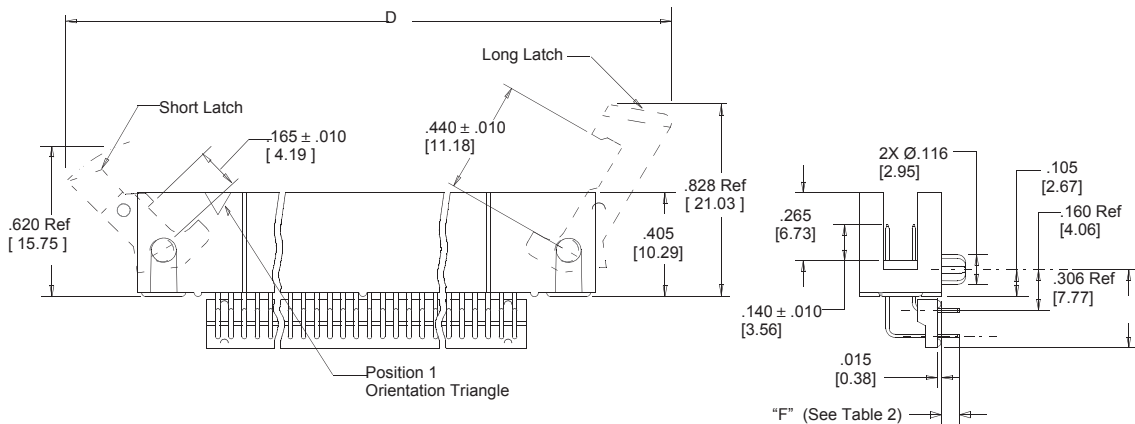

- Notes:
 1. This polarization bump does not exist on the 20 position header.
 2. Recommended to be mated to the .050" X .100" Wiremount Socket 820 Series.

Ordering Information

PTH Right Angle Header 81XXX - 5X0X03 - XX

Ejector Latches (If Ordered Separately)

Long Latches
 3505-28 (natural)
 3505-28B (black)

Short Latches
 3505-29 (natural)
 3505-29B (black)

Contact Quantity
(See Table 1)

Ejector/Latch System:
 0 = None (Special Order)
 5 = With Short Ejectors Installed (Special Order)
 6 = With Long Ejector Latches Installed (Standard)

Plating suffix:
 blank = 125 μ" tin lead tails (RIA E3 & C2 apply)
 RB = 250 μ" matte tin tails (RIA E1 & C1 apply)

Contact Tail:
 2 = Solder Tail for .062 [1.57] PC Board (Standard)
 3 = Solder Tail for .094 [2.39] PC Board (Special Order)
 4 = Solder Tail for .125 [3.18] PC Board (Special Order)

TS-0253-G
 Sheet 2 of 7

3M™ 4-Wall, Tripolarized Header

.050" × .100" Latch/Ejector, PTH & SMT Straight, PTH Right Angle

810 Series

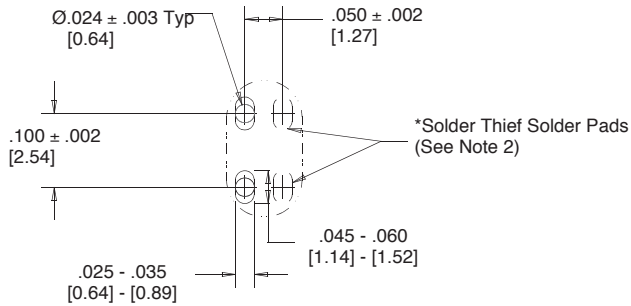

Ejector Latches	Dimension E Min
None	.575 [14.61]
Long	1.010 [25.65]
Short	.885 [22.48]

*Solder Thief Solder Pads required only on Solder side of PC Board.

View A

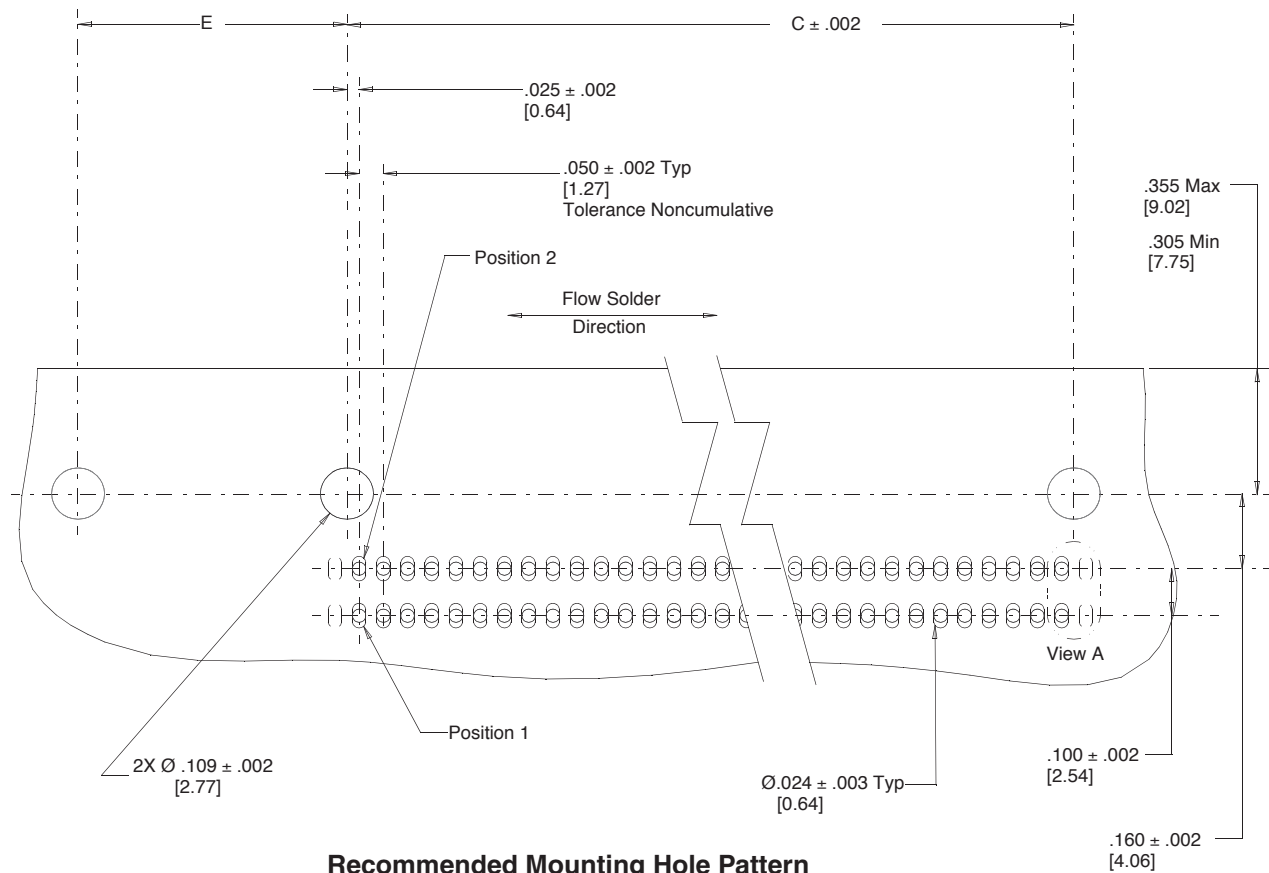

Recommended Mounting Hole Pattern PTH Right Angle Header (shown for mounting side of PC Board)

Notes:

1. Recommended to process PC Boards through the solder bath such that the connector enters end first (two solder tails at a time). This will help prevent solder bridging.
2. A Dummy or Solder Thief Solder Pad at the end of each row is recommended on the bottom or solder side of the PC Board in order to help prevent solder bridging on the end solder tails. The solder thieves are only required on the end of the rows which leave the solder bath last.
3. In order to facilitate soldering it is recommended that ejector latches be installed after the soldering process.

TS-0253-G
Sheet 3 of 7

3M™ 4-Wall, Tripolarized Header

.050" × .100" Latch/Ejector, PTH & SMT Straight, PTH Right Angle

810 Series



Contact Quantity	Dimensions				
	A	B	C Short (Ref.)	C Long (Ref.)	D
020	1.060 [26.92]	0.722 [18.34]	1.671 [42.44]	1.842 [46.79]	0.860 [21.84]
026	1.210 [30.73]	0.872 [22.15]	1.821 [46.25]	1.992 [50.60]	1.010 [25.65]
036	1.460 [37.08]	1.122 [28.50]	2.071 [52.60]	2.242 [56.95]	1.260 [32.00]
040	1.560 [39.62]	1.222 [31.04]	2.171 [55.14]	2.342 [59.49]	1.360 [34.54]
050	1.810 [45.97]	1.472 [37.39]	2.421 [61.49]	2.592 [65.84]	1.610 [40.89]
060	2.060 [52.32]	1.722 [43.74]	2.671 [67.84]	2.842 [72.19]	1.860 [47.24]
068	2.260 [57.40]	1.922 [48.82]	2.871 [72.92]	3.042 [77.27]	2.060 [52.32]
080	2.560 [65.02]	2.222 [56.44]	3.171 [80.54]	3.342 [84.89]	2.360 [59.94]
100	3.060 [77.72]	2.722 [69.14]	3.671 [93.24]	3.842 [97.59]	2.860 [72.64]

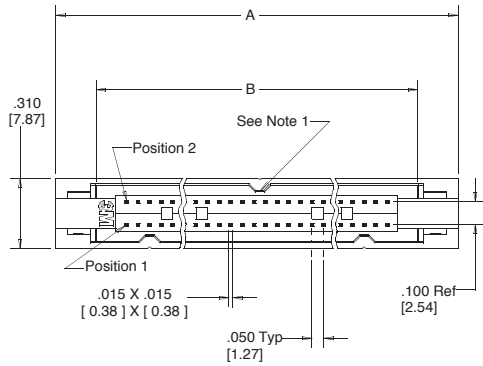

PCB Thickness	"F" Solder Tail Length ± .010
.062 [1.57]	.092 [2.34]
.094 [2.39]	.110 [2.79]

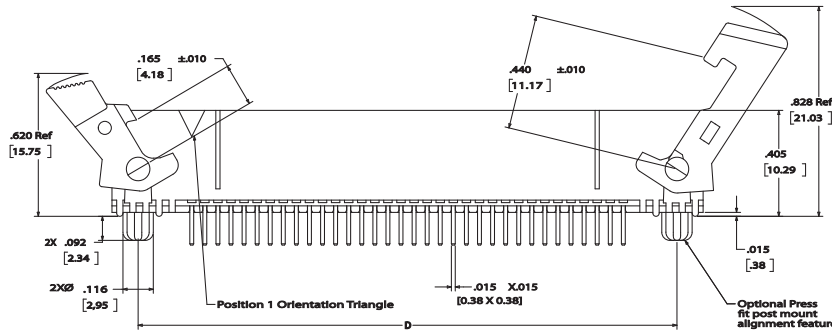
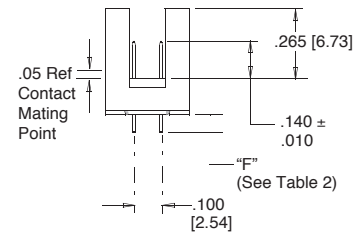

Notes:

1. This polarization bump does not exist on the 20 position header.
2. Recommended to be mated to the .050" x .100" 820 Series Socket.

Ordering Information

PTH Straight Header 81XXX - 6X0X0X - XX

Ejector Latches

(If Ordered Separately)

Long Latches

- 3505-28 (natural)
- 3505-28B (black)

Short Latches

- 3505-29 (natural)
- 3505-29B (black)

Contact Quantity
(See Table 4)

Ejector/Latch System:

- 0 = None (Special Order)
- 5 = With Short Ejectors Installed (Special Order)
- 6 = With Long Ejector Latches Installed (Standard)

Board Mounting Options:

- 1 = None (Special Order)
- 3 = Press fit posts both ends (Standard)

Contact Tail:

- 2 = Solder Tail for .062 [1.57] PC Board (Standard)
- 3 = Solder Tail for .094 [2.39] PC Board (Special Order)
- 4 = Solder Tail for .125 [.318] PC Board (Special Order)

Plating suffix:

- blank = 125 μ" tin lead tails (RIA E3 & C2 apply)
- RB = 250 μ" matte tin tails (RIA E1 & C1 apply)

TS-0253-G
Sheet 4 of 7

3M™ 4-Wall, Tripolarized Header

.050" × .100" Latch/Ejector, PTH & SMT Straight, PTH Right Angle

810 Series

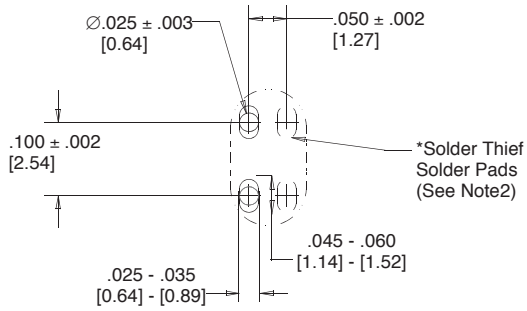

*Solder Thief Solder Pads required only on Solder side of PC Board.

View A

Ejector/Latches	Dimension E (Min)
None	.215 [5.46]
Long	.650 [16.51]
Short	.525 [13.34]

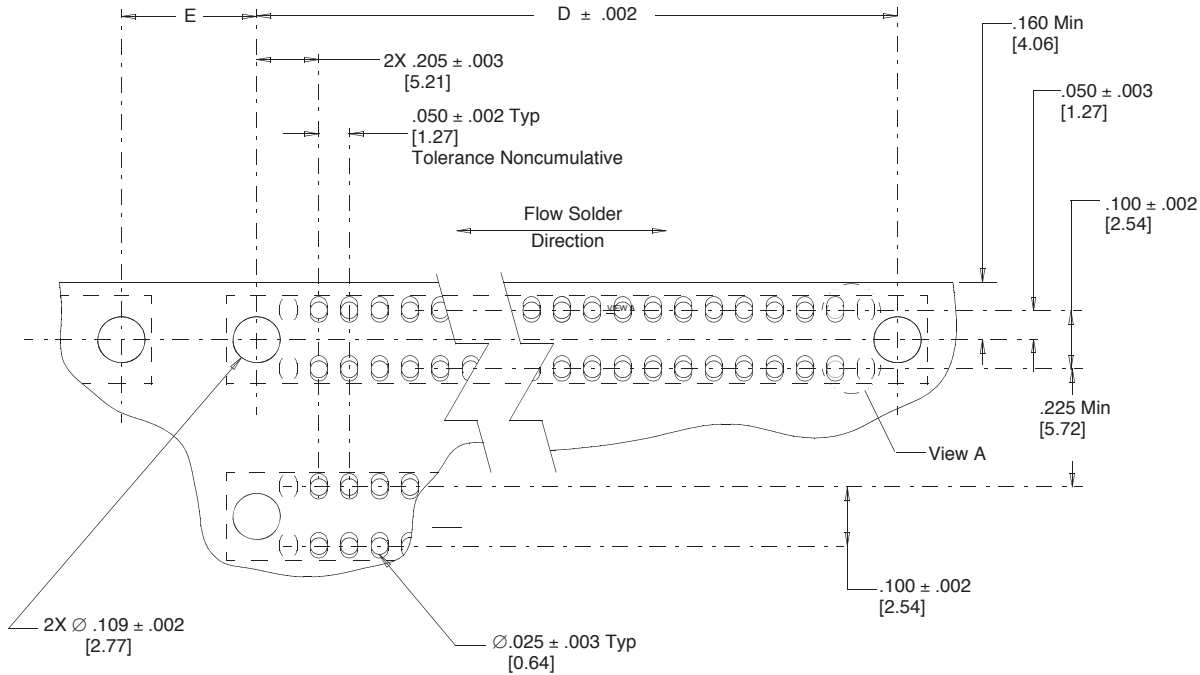

**Recommended Mounting Hole Pattern
PTH Vertical Header**
(shown for mounting side of PC Board)

Inch [Imm]			
Tolerance Unless Noted			
	.0	.00	.000
Inch	±.1	±.01	±.005

[] Dimensions for Reference Only

Note:

1. Recommended to process PC Boards through the solder bath such that the connector enters end first (two solder tails at a time). This will help prevent solder bridging.
2. A Solder Thief Solder Pad (Dummy Pad) at the end of each row is recommended on the bottom or solder side of the PC Board in order to help prevent solder bridging on the end solder tails. The Solder Thiefs are only required on the end of the rows which leave the solder bath last.

TS-0253-G
Sheet 5 of 7

3M™ 4-Wall, Tripolarized Header

.050" × .100" Latch/Ejector, PTH & SMT Straight, PTH Right Angle

810 Series

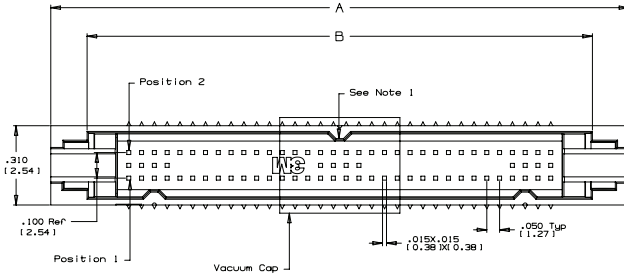

Contact Quantity	Dimensions				Tape & Reel Suffix
	A	B	D Short (Ref.)	D Long (Ref.)	
020	1.060 [26.92]	0.722 [18.34]	1.671 [42.44]	1.842 [46.79]	WD
026	1.210 [30.73]	0.872 [22.15]	1.821 [46.25]	1.992 [50.60]	WF
036	1.460 [37.08]	1.122 [28.50]	2.071 [52.60]	2.242 [56.95]	
040	1.560 [39.62]	1.222 [31.04]	2.171 [55.14]	2.342 [59.49]	
050	1.810 [45.97]	1.472 [37.39]	2.421 [61.49]	2.592 [65.84]	WF
060	2.060 [52.32]	1.722 [43.74]	2.671 [67.84]	2.842 [72.19]	
068	2.260 [57.40]	1.922 [48.82]	2.871 [72.92]	3.042* [77.27]	WG
080	2.560 [65.02]	2.222 [56.44]	3.171* [80.54]	3.342* [84.89]	
100	3.060 [77.72]	2.722 [69.14]	3.671 [93.24]	3.842 [97.59]	WH

*Requires WH pocket tape

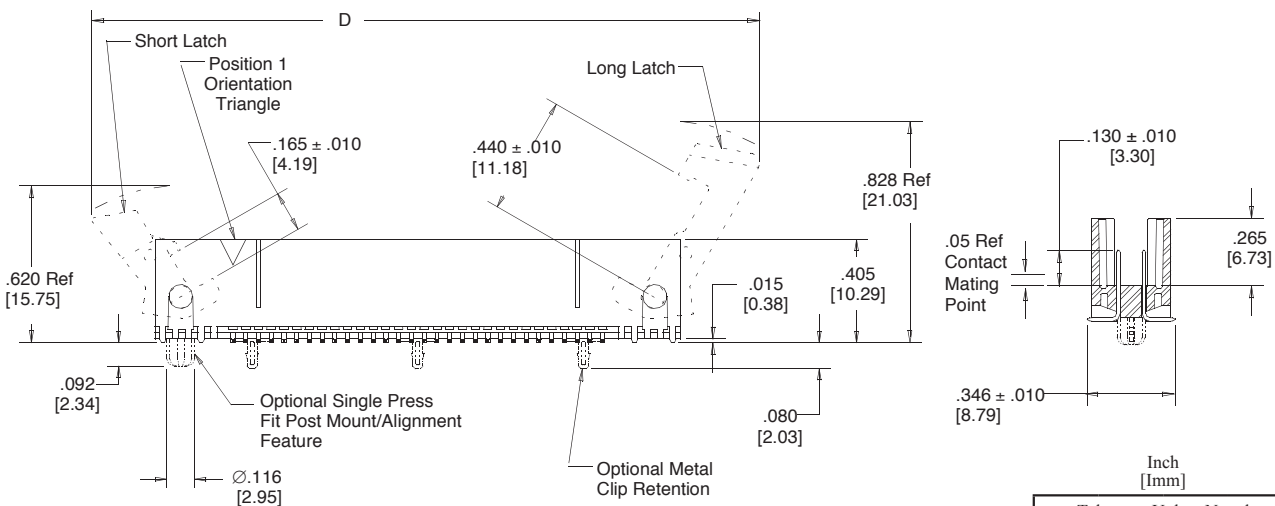

Tolerance Unless Noted			
	.0	.00	.000
Inch	±.1	±.01	±.005

[] Dimensions for Reference Only

- Notes:
- This polarization bump does not exist on the 20 position header.
 - Recommended to be mated to the .050" X .100" 820 Series Wiremount Socket.

Ordering Information

SMT Straight Header 81XXX - 6X0C0X - XX - XX

Ejector Latches

(If Ordered Separately)

Contact Quantity
(See Table 7)

Ejector/Latch System:

- 0 = None (Special Order)
- 5 = With Short Ejectors Installed (Special Order)
- 6 = With Long Ejector Latches Installed (Standard)

Board Mounting Options:

- 1 = None
- 4 = Press Fit Post Mount at Position 1 end
- 7 = Metal retention clips
- 8 = #1 end press fit post & metal retention clips (Special Order)

Packaging Options:

- Blank = Trays
- WX = Tape & Reel Package (see table)

Plating suffix:

- blank = 125 μ" tin lead tails (RIA E3 & C2 apply)
- RB = 250 μ" matte tin tails (RIA E1 & C1 apply)

Long Latches

- 3505-28 (natural)
- 3505-28B (black)

Short Latches

- 3505-29 (natural)
- 3505-29B (black)

TS-0253-G
Sheet 6 of 7

3M™ 4-Wall, Tripolarized Header

.050" × .100" Latch/Ejector, PTH & SMT Straight, PTH Right Angle

810 Series

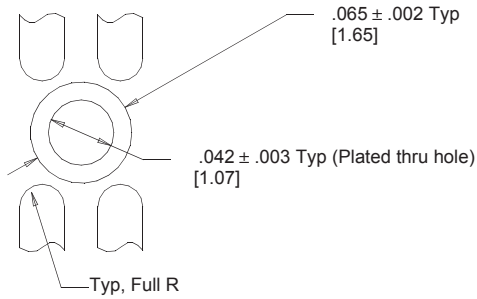

Detail A
Optional plated thru hole
for metal clip retention

Ejector Latches	Dimensions	
	H Min	
None	.775 [19.69]	
Long	1.085 [27.56]	
Short	1.21 [30.73]	

No. of Positions	Dimensions	
	F	G
20	.450 [11.43]	N/A
26	.600 [15.24]	.025 [0.64]
36	.850 [21.59]	N/A
40	.950 [24.13]	N/A
50	1.200 [30.48]	.025 [.64]
60	1.450 [36.83]	0.000
68	1.650 [41.91]	0.000
80	1.950 [49.53]	0.000
100	2.450 [62.23]	0.000

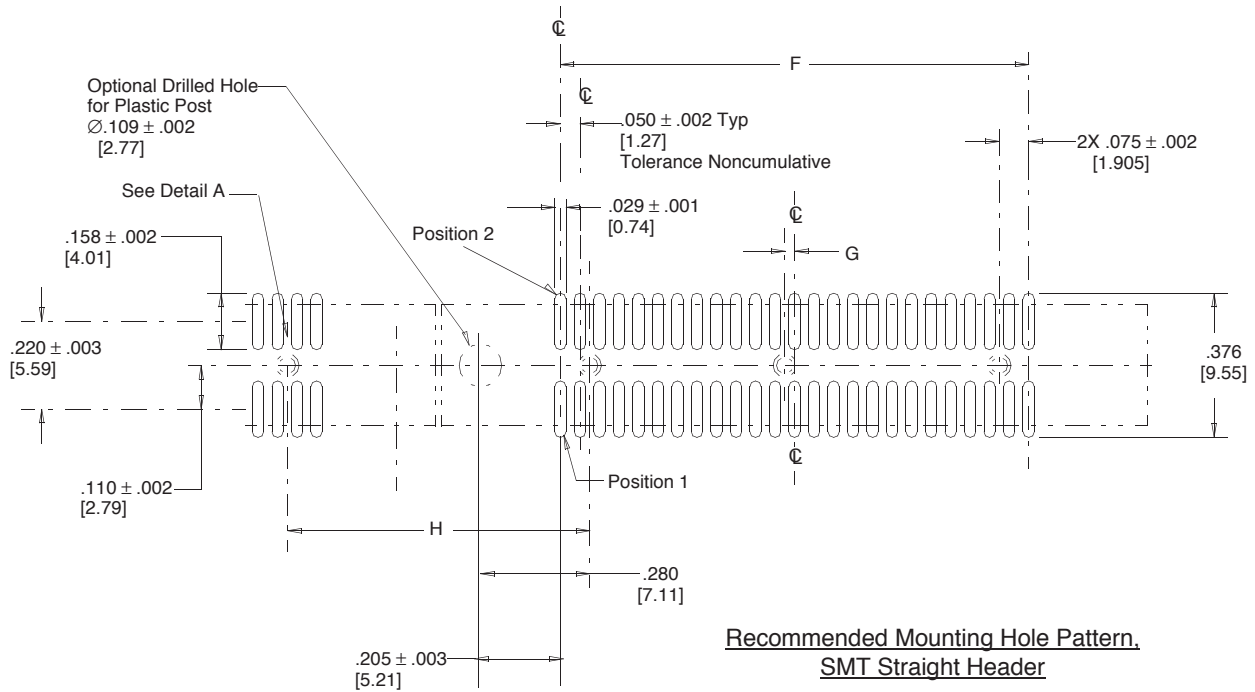

**Recommended Mounting Hole Pattern,
SMT Straight Header**

(Shown for mounting side of PC Board)

TS-0253-G
Sheet 7 of 7

Important Notice

All statements, technical information, and recommendations related to 3M's products are based on information believed to be reliable, but the accuracy or completeness is not guaranteed. Before using this product, you must evaluate it and determine if it is suitable for your intended application. You assume all risks and liability associated with such use. Any statements related to the product which are not contained in 3M's current publications, or any contrary statements contained on your purchase order shall have no force or effect unless expressly agreed upon, in writing, by an authorized officer of 3M.

Warranty; Limited Remedy; Limited Liability.

This product will be free from defects in material and manufacture for a period of ninety (90) days from the time of purchase. **3M MAKES NO OTHER WARRANTIES INCLUDING, BUT NOT LIMITED TO, ANY IMPLIED WARRANTY OF MERCHANTABILITY OR FITNESS FOR A PARTICULAR PURPOSE.** If this product is defective within the warranty period stated above, your exclusive remedy shall be, at 3M's option, to replace or repair the 3M product or refund the purchase price of the 3M product. **Except where prohibited by law, 3M will not be liable for any indirect, special, incidental or consequential loss or damage arising from this 3M product, regardless of the legal theory asserted.**

**3M Electronics Solutions Division**

6801 River Place Blvd.
Austin, TX 78726-9000
U.S.A.
1-800-225-5373
www.3Mconnector.com

Please recycle. Printed in USA.
© 3M 2010. All rights reserved.
RIA-2217B-E

3M is a trademark of 3M Company.