

Intel® IXP42X Product Line of Network Processors and IXC1100 Control Plane Processor

Datasheet

Product Features

For a complete list of product features, see “Product Features” on page 10.

The following features *do not* require enabling software:

- Intel XScale® Processor — Up to 533 MHz
- PCI Interface
- USB v1.1 Device Controller
- SDRAM Interface
- High-Speed UART
- Console UART
- Internal Bus Performance Monitoring Unit
- 16 GPIOs
- Four Internal Timers
- Packaging — 492-pin PBGA
- Commercial/Extended Temperature

The following features *do* require enabling software:

- Encryption/Authentication (AES, DES, 3DES, SHA-1, MD5)
- Two High-Speed, Serial Interfaces
- Three Network Processor Engines
- Up to two MII Interfaces
- One UTOPIA Level 2 Interface
- Multi-Channel HDLC

Note: Refer to the *Intel® IXP400 Software Programmer's Guide* for information on which features are currently enabled.

Typical Applications

- High-Performance DSL Modem
- High-Performance Cable Modem
- Residential Gateway
- SME Router
- Network Printers
- Control Plane
- Integrated Access Device (IAD)
- Set-Top Box
- Access Points (802.11a/b/g)
- Industrial Controllers

Document Number: 252479-007US
June 2007



INFORMATION IN THIS DOCUMENT IS PROVIDED IN CONNECTION WITH INTEL® PRODUCTS. NO LICENSE, EXPRESS OR IMPLIED, BY ESTOPPEL OR OTHERWISE, TO ANY INTELLECTUAL PROPERTY RIGHTS IS GRANTED BY THIS DOCUMENT. EXCEPT AS PROVIDED IN INTEL'S TERMS AND CONDITIONS OF SALE FOR SUCH PRODUCTS, INTEL ASSUMES NO LIABILITY WHATSOEVER, AND INTEL DISCLAIMS ANY EXPRESS OR IMPLIED WARRANTY, RELATING TO SALE AND/OR USE OF INTEL PRODUCTS INCLUDING LIABILITY OR WARRANTIES RELATING TO FITNESS FOR A PARTICULAR PURPOSE, MERCHANTABILITY, OR INFRINGEMENT OF ANY PATENT, COPYRIGHT OR OTHER INTELLECTUAL PROPERTY RIGHT. Intel products are not intended for use in medical, life saving, life sustaining, critical control or safety systems, or in nuclear facility applications.

Intel may make changes to specifications and product descriptions at any time, without notice.

Intel Corporation may have patents or pending patent applications, trademarks, copyrights, or other intellectual property rights that relate to the presented subject matter. The furnishing of documents and other materials and information does not provide any license, express or implied, by estoppel or otherwise, to any such patents, trademarks, copyrights, or other intellectual property rights.

Designers must not rely on the absence or characteristics of any features or instructions marked "reserved" or "undefined." Intel reserves these for future definition and shall have no responsibility whatsoever for conflicts or incompatibilities arising from future changes to them.

Intel processor numbers are not a measure of performance. Processor numbers differentiate features within each processor family, not across different processor families. See http://www.intel.com/products/processor_number for details.

The Intel® IXP42X Product Line of Network Processors and IXC1100 Control Plane Processor may contain design defects or errors known as errata which may cause the product to deviate from published specifications. Current characterized errata are available on request.

Contact your local Intel sales office or your distributor to obtain the latest specifications and before placing your product order.

Copies of documents which have an order number and are referenced in this document, or other Intel literature may be obtained by calling 1-800-548-4725 or by visiting Intel's website at <http://www.intel.com>.

BunnyPeople, Celeron, Celeron Inside, Centrino, Centrino logo, Core Inside, FlashFile, i960, InstantIP, Intel, Intel logo, Intel386, Intel486, Intel740, IntelDX2, IntelDX4, IntelSX2, Intel Core, Intel Inside, Intel Inside logo, Intel. Leap ahead., Intel. Leap ahead. logo, Intel NetBurst, Intel NetMerge, Intel NetStructure, Intel SingleDriver, Intel SpeedStep, Intel StrataFlash, Intel Viiv, Intel vPro, Intel XScale, Itanium, Itanium Inside, MCS, MMX, Oplus, OverDrive, PDCharm, Pentium, Pentium Inside, skool, Sound Mark, The Journey Inside, VTune, Xeon, and Xeon Inside are trademarks of Intel Corporation in the U.S. and other countries.

*Other names and brands may be claimed as the property of others.

Copyright © 2007, Intel Corporation. All Rights Reserved.



Contents

1.0	Introduction	9
1.1	About this Document	9
1.2	Product Features	10
1.2.1	Product Line Features	10
1.2.2	Processor Features	13
2.0	Functional Overview	14
2.1	Functional Units	18
2.1.1	Network Processor Engines (NPEs)	18
2.1.2	Internal Bus	19
2.1.2.1	North AHB	20
2.1.2.2	South AHB	20
2.1.2.3	APB Bus	20
2.1.3	MII Interfaces	21
2.1.4	UTOPIA Level 2	21
2.1.5	USB Interface	21
2.1.6	PCI Controller	21
2.1.7	SDRAM Controller	22
2.1.8	Expansion Bus	22
2.1.9	High-Speed, Serial Interfaces	23
2.1.10	High-Speed and Console UARTs	23
2.1.11	GPIO	23
2.1.12	Internal Bus Performance Monitoring Unit (IBPMU)	23
2.1.13	Interrupt Controller	24
2.1.14	Timers	24
2.1.15	AHB Queue Manager	24
2.2	Intel XScale® Processor	24
2.2.1	Super Pipeline	25
2.2.2	Branch Target Buffer (BTB)	26
2.2.3	Instruction Memory Management Unit (IMMU)	27
2.2.4	Data Memory Management Unit (DMMU)	27
2.2.5	Instruction Cache (I-Cache)	27
2.2.6	Data Cache (D-Cache)	28
2.2.7	Mini-Data Cache	28
2.2.8	Fill Buffer (FB) and Pend Buffer (PB)	29
2.2.9	Write Buffer (WB)	29
2.2.10	Multiply-Accumulate Coprocessor (CPO)	29
2.2.11	Performance Monitoring Unit (PMU)	30
2.2.12	Debug Unit	30
3.0	Functional Signal Descriptions	30
3.1	Pin Description Tables	32
4.0	Package and Pinout Information	47
4.1	Package Description	47
4.2	Signal-Pin Descriptions	49
4.3	Package Thermal Specifications	76
4.3.1	Commercial Temperature	77
4.3.2	Extended Temperature	77
5.0	Electrical Specifications	77
5.1	Absolute Maximum Ratings	77
5.2	V _{CCPLL1} , V _{CCPLL2} , V _{CCOSCP} , V _{CCOSC} Pin Requirements	78



5.2.1	V _{CCPLL1} Requirement	78
5.2.2	V _{CCPLL2} Requirement	78
5.2.3	V _{CCOSCP} Requirement	79
5.2.4	V _{CCOSC} Requirement	79
5.3	RCOMP Pin Requirements	80
5.4	DC Specifications	81
5.4.1	Operating Conditions	81
5.4.2	PCI DC Parameters	81
5.4.3	USB DC Parameters	81
5.4.4	UTOPIA Level 2 DC Parameters	82
5.4.5	MII DC Parameters	82
5.4.6	MDIO DC Parameters	82
5.4.7	SDRAM Bus DC Parameters	83
5.4.8	Expansion Bus DC Parameters	83
5.4.9	High-Speed, Serial Interface 0 DC Parameters	84
5.4.10	High-Speed, Serial Interface 1 DC Parameters	84
5.4.11	High-Speed and Console UART DC Parameters	84
5.4.12	GPIO DC Parameters	85
5.4.13	JTAG AND PLL_LOCK DC Parameters	85
5.4.14	Reset DC Parameters	85
5.5	AC Specifications	86
5.5.1	Clock Signal Timings	86
5.5.1.1	Processor Clock Timings	86
5.5.1.2	PCI Clock Timings	87
5.5.1.3	MII Clock Timings	87
5.5.1.4	UTOPIA Level 2 Clock Timings	88
5.5.1.5	Expansion Bus Clock Timings	88
5.5.2	Bus Signal Timings	88
5.5.2.1	PCI	88
5.5.2.2	USB Interface	90
5.5.2.3	UTOPIA Level 2 (33 MHz)	90
5.5.2.4	MII	91
5.5.2.5	MDIO	92
5.5.2.6	SDRAM Bus	93
5.5.2.7	Expansion Bus	95
5.5.2.8	High-Speed, Serial Interfaces	120
5.5.2.9	JTAG	121
5.5.3	Reset Timings	122
5.5.3.1	Cold Reset	122
5.5.3.2	Hardware Warm Reset	123
5.5.3.3	Soft Reset	123
5.5.3.4	Reset Timings	124
5.6	Power Sequence	125
5.7	I _{CC} and Total Average Power	126
6.0	Ordering Information	128



Figures

1	Intel® IXP425 Network Processor Block Diagram	15
2	Intel® IXP423 Network Processor Block Diagram	16
3	Intel® IXP422 Network Processor Block Diagram	17
4	Intel® IXP421 Network Processor Block Diagram	17
5	Intel® IXP420 Network Processor Block Diagram	18
6	Intel XScale® Technology Block Diagram	25
7	492-Pin Lead PBGA Package	47
8	Package Markings	48
9	V _{CCPLL1} Power Filtering Diagram	78
10	V _{CCPLL2} Power Filtering Diagram	79
11	V _{CCSCP} Power Filtering Diagram	79
12	V _{CCOSC} Power Filtering Diagram	80
13	RCOMP Pin External Resistor Requirements	80
14	Typical Connection to an Oscillator	87
15	PCI Output Timing	88
16	PCI Input Timing	89
17	UTOPIA Level 2 Input Timings	90
18	UTOPIA Level 2 Output Timings	90
19	MII Output Timings	91
20	MII Input Timings	92
21	MDIO Output Timings	92
22	MDIO Input Timings	93
23	SDRAM Input Timings	93
24	SDRAM Output Timings	94
25	Signal Timing With Respect to Clock Rising Edge	95
26	Intel® Multiplexed Read Mode	96
27	Intel® Multiplexed Write Mode	97
28	Intel® Simplex Read Mode	99
29	Intel® Simplex Write Mode	100
30	Motorola* Multiplexed Read Mode	102
31	Motorola* Multiplexed Write Mode	103
32	Motorola* Simplex Read Mode	104
33	Motorola* Simplex Write Mode	105
34	HPI-8 Mode Read Accesses	107
35	HPI-8 Mode Write Accesses	108
36	HPI-16 Multiplexed Write Mode	111
37	HPI-16 Multiplex Read Mode	113
38	HPI-16 Simplex Read Mode	115
39	HPI-16 Simplex Write Mode	117
40	I/O Wait Normal Phase Timing	118
41	I/O Wait Extended Phase Timing	119
42	High-Speed, Serial Timings	120
43	Boundary-Scan General Timings	121
44	Boundary-Scan Reset Timings	122
45	Reset Timings	124
46	Power-Up Sequence Timing	126



Tables

1	Related Documents.....	9
2	Terminology and Acronyms.....	9
3	Processor Features.....	13
4	Processor Functions.....	19
5	Signal Type Definitions.....	31
6	Processors' Signal Interface Summary Table.....	31
7	SDRAM Interface.....	33
8	PCI Controller.....	34
9	High-Speed, Serial Interface 0.....	36
10	High-Speed, Serial Interface 1.....	37
11	MII Interfaces.....	38
12	UTOPIA Level 2 Interface.....	40
13	Expansion Bus Interface.....	41
14	UART Interfaces.....	42
15	USB Interface.....	43
17	GPIO Interface.....	44
16	Oscillator Interface.....	44
18	JTAG Interface.....	45
19	System Interface††.....	45
20	Power Interface.....	46
21	Part Numbers for the Intel® IXP42X Product Line of Network Processors.....	48
22	Ball Map Assignment for the Intel® IXP425 Network Processor.....	49
23	Ball Map Assignment for the Intel® IXP422 Network Processor.....	56
24	Ball Map Assignment for the Intel® IXP421 Network Processor.....	63
25	Ball Map Assignment for the Intel® IXP420 Network Processor and Intel® IXC1100 Control Plane Processor.....	70
26	Operating Conditions.....	81
27	PCI DC Parameters.....	81
28	USB v1.1 DC Parameters.....	81
29	UTOPIA Level 2 DC Parameters.....	82
30	MII DC Parameters.....	82
31	MDIO DC Parameters.....	82
32	SDRAM Bus DC Parameters.....	83
33	Expansion Bus DC Parameters.....	83
34	High-Speed, Serial Interface 0 DC Parameters.....	84
35	High-Speed, Serial Interface 1 DC Parameters.....	84
36	UART DC Parameters.....	84
37	GPIO DC Parameters.....	85
38	JTAG AND PLL_LOCK DC Parameters @ 3.3V.....	85
39	PWRON_RESET_N DC Parameters.....	85
40	RESET_IN_N Parameters @ 3.3V.....	86
41	Devices' Clock Timings (Oscillator Reference).....	86
42	Processors' Clock Timings Spread Spectrum Parameters.....	86
43	PCI Clock Timings.....	87
44	MII Clock Timings.....	87
45	UTOPIA Level 2 Clock Timings.....	88
46	Expansion Bus Clock Timings.....	88
47	PCI Bus Signal Timings.....	89
48	UTOPIA Level 2 Input Timings Values.....	90
49	UTOPIA Level 2 Output Timings Values.....	91
50	MII Output Timings Values.....	91
51	MII Input Timings Values.....	92
52	MDIO Timings Values.....	93



53	SDRAM Input Timings Values.....	93
54	SDRAM Output Timings Values.....	94
55	Signal Timing With Respect to Clock Rising Edge.....	95
56	Intel® Multiplexed Mode Values.....	98
57	Intel Simplex Mode Values.....	101
58	Motorola* Multiplexed Mode Values.....	103
59	Motorola* Simplex Mode Values.....	105
60	HPI Timing Symbol Description.....	109
61	HPI-8 Mode Write Access Values.....	109
62	HPI-16 Multiplexed Write Accesses Values.....	110
63	HPI-16 Multiplexed Read Accesses Values.....	112
64	HPI-16 Simplex Read Accesses Values.....	114
65	HPI-16 Simplex Write Accesses Values.....	116
66	High-Speed, Serial Timing Values.....	121
67	Boundary-Scan Interface Timings Values.....	122
68	Reset Timings Table Parameters.....	125
69	I _{CC} and Total Average Power – Commercial Temperature Range.....	126
70	I _{CC} and Total Average Power – Extended Temperature Range.....	127



Revision History

Date	Revision	Description
June 2007	007	1. Added B-1 stepping information
August 2006	006	<ol style="list-style-type: none"> 1. Table 3, Table 21: Added the FWIXP423BD, 533 MHz IXP423 2. Clarified GPIO functions in Section 2.1.11 3. Updated Pin Types in Table 11 and Table 12 4. Added Section 3.1 to help explain the tables outlined in Table 6 5. Modified some signals in Table 8 through Table 17 to be pulled up when unused in new designs. No change to existing designs. 6. Updated Power on Reset or Sys Reset column values in Table 17 and Table 19 7. Table 21: Removed the IXC1100 8. Corrected the maximum Talepulse value in Table 55 9. Clarified ordering information in Section 6.0 10. Updated Intel® product branding. References to Intel XScale core were updated to Intel XScale Processor. 11. Incorporated specification changes, specification clarifications and document changes from the <i>Intel® IXP4XX Product Line of Network Processors Specification Update (306428-004)</i>
March 2005	005	<ol style="list-style-type: none"> 1. Rearranged product features lists in Section 1.2, “Product Features” 2. Added two new columns to Table 3 to indicate Software Enable/Disable, and IXP423 network processor features 3. Replaced network processor block diagrams: Figure 1, Figure 2, Figure 3, Figure 4, and Figure 5 4. Added new row for the IXP423 network processor to Table 4, “Processor Functions” 5. Corrected the PCI_IDSEL definition in Table 8, “PCI Controller” 6. Added pull-up resistor requirement for the ETH_MDIO pin in Table 11, “MII Interfaces” 7. Added footnote to Table 19, “System Interfacet††” regarding system level reset 8. Added part number for IXP423 on Table 21, “Part Numbers for the Intel® IXP42X Product Line of Network Processors” 9. Added note 4 to Table 27, “PCI DC Parameters” 10. Changed VIH “Minimum” parameter to 2.0 in Table 28, “USB v1.1 DC Parameters” (see the <i>Intel® IXP4XX Product Line of Network Processors Specification Update (306428)</i>); added note 2 11. Added new paragraph to Section 5.5.1.1, “Processor Clock Timings” regarding crystal oscillators application 12. Added footnote regarding PLL operation at the lowest slew rate to Table 41, “Devices’ Clock Timings (Oscillator Reference)” 13. Added footnote to Table 51, “MII Input Timings Values” and Table 52, “MDIO Timings Values” 14. Inserted new Figure 25, “Signal Timing With Respect to Clock Rising Edge” 15. Replaced Expansion Bus figures: Figure 25–Figure 39 16. Updated Table 55, “Signal Timing With Respect to Clock Rising Edge” 17. Updated Trdsetup and Trdhold values in Table 56, Table 57, Table 58 and Table 59 18. Added footnotes to Table 63, “HPI-16 Multiplexed Read Accesses Values” 19. Replaced Table 69, “I_{CC} and Total Average Power – Commercial Temperature Range”, and inserted new Table 70, “I_{CC} and Total Average Power – Extended Temperature Range”
June 2004	004	Updated Intel® product branding. Change bars are retained from the previous release of this document (-003).
April 2004	003	Incorporated specification changes, specification clarifications and document changes from the <i>Intel® IXP42X Product Line of Network Processors and IXC1100 Control Plane Processor Specification Update (252702-003)</i> .
May 2003	002	Incorporated specification changes, specification clarifications and document changes from the <i>Intel® IXP42X Product Line of Network Processors Specification Update (252702-001)</i> . Incorporated information for the Intel® IXC1100 Control Plane Processor.
February 2003	001	Initial release of this document. Document reissued, without “Confidential” marking.





1.0 Introduction

1.1 About this Document

This datasheet contains a functional overview of the Intel® IXP42X Product Line of Network Processors and IXC1100 Control Plane Processor, mechanical data (package signal locations and simulated thermal characteristics), targeted electrical specifications, and some bus functional wave forms for the device. Detailed functional descriptions other than parametric performance are published in the *Intel® IXP42X Product Line of Network Processors and IXC1100 Control Plane Processor Developer's Manual*.

Other related documents are shown in [Table 1](#).

Table 1. Related Documents

Document Title	Document #
<i>Intel® IXP4XX Product Line of Network Processors Specification Update</i>	306428
<i>Intel® IXP42X Product Line of Network Processors and IXC1100 Control Plane Processor Developer's Manual</i>	252480
<i>Intel® IXP400 Software Programmer's Guide</i>	252539
<i>Intel® IXP400 Software Specification Update</i>	273795
<i>Intel XScale® Core Developer's Manual</i>	273473
<i>Intel® IXP42X Product Line of Network Processors and IXC1100 Control Plane Processor Hardware Design Guidelines</i>	252817
<i>Intel XScale® Microarchitecture Technical Summary</i>	—
<i>PCI Local Bus Specification, Rev. 2.2</i>	—
<i>Universal Serial Bus Specification, Revision 1.1</i>	—

Table 2. Terminology and Acronyms

Acronym/ Terminology	Description
AAL	ATM Adaptation Layers
AES	Advanced Encryption Standard
AHB	Advanced High-Performance Bus
APB	Advanced Peripheral Bus
API	Application Program Interface
Assert	The logically active value of a signal or bit.
ATM	Asynchronous Transmission Mode
AQM	AHB Queue Manager
BTB	Branch Target Buffer
CRC	Cyclical Redundancy Check
Deassert	The logically inactive value of a signal or bit.
DDR	Double Data Rate
DES	Data-Encryption Standard
DMA	Direct Memory Access
DSP	Digital Signal Processor



Table 2. Terminology and Acronyms (Continued)

Acronym/ Terminology	Description
E1	Euro 1 trunk line
FIFO	First In First Out
GCI	General Circuit Interface
GPIO	General-purpose input/output
HDLC	High-level Data Link Control
HPI	(Texas Instruments*) Host Port Interfaces
HSS	High-Speed Serial (port)
LSb	Least-Significant bit
LSB	Least-Significant Byte
MAC	Media Access Controller
MDIO	Management Data Input/Output
MII	Media-Independent Interface
MMU	Memory Management Unit
MSb	Most-Significant bit
MSB	Most-Significant Byte
NPE	Network Processor Engine
PCI	Peripheral Component Interconnect
PHY	Physical Layer (Layer 1) Interface
Reserved	A field that may be used by an implementation. Software should not modify reserved fields or depend on any values in reserved fields.
RX	Receive (HSS is receiving from off-chip)
SRAM	Static Random Access Memory
SDRAM	Synchronous Dynamic Random Access Memory
T1	Type 1 trunk line
TX	Transmit (HSS is transmitting off-chip)
UART	Universal Asynchronous Receiver-Transmitter
USB	Universal Serial Bus
UTOPIA	Universal Test and Operations PHY Interface for ATM
WAN	Wide Area Network

1.2 Product Features

1.2.1 Product Line Features

This section outlines the features that apply to the Intel® IXP42X Product Line of Network Processors and IXC1100 Control Plane Processor.

Some of the features described in this document require enablement by software delivered by Intel. Some features may not be enabled with current software releases.



The features that require software are identified below. Refer to the *Intel® IXP400 Software Programmer's Guide* for information on features that are currently enabled.

- Intel XScale® Processor (compliant with ARM* architecture)
 - High-performance processor based on Intel XScale® Microarchitecture
 - Seven/eight-stage Intel® Super-Pipelined RISC Technology
 - Management unit
 - 32-entry, data memory management unit
 - 32-entry, instruction memory management unit
 - 32-Kbyte, 32-way, set associative instruction cache
 - 32-Kbyte, 32-way, set associative data cache
 - 2-Kbyte, two-way, set associative mini-data cache
 - 128-entry, branch target buffer
 - Eight-entry write buffer
 - Four-entry fill and pend buffers
 - Clock speeds:
 - 266 MHz
 - 400 MHz
 - 533 MHz
 - ARM* Version V5TE Compliant
 - Intel® Media Processing Technology Multiply-accumulate coprocessor
 - Debug unit
Accessible through JTAG port
- PCI interface
 - 32-bit interface
 - Selectable clock
 - 33 MHz clock output derived from either GPIO14 or GPIO15
 - 33 and 66 MHz clock input
 - *PCI Local Bus Specification, Rev. 2.2* compatible
 - PCI arbiter supporting up to four external PCI devices (four REQ/GNT pairs)
 - Host/option capable
 - Master/target capable
 - Two DMA channels
- USB v 1.1 device controller
 - Full-speed capable
 - Embedded transceiver
 - 16 endpoints
- SDRAM interface
 - 32-bit data
 - 13-bit address
 - 133 MHz
 - Up to eight open pages simultaneously maintained
 - Programmable auto-refresh
 - Programmable CAS/data delay



- Support for 8 MB, minimum, up to 256 MB maximum
- Expansion interface
 - 24-bit address
 - 16-bit data
 - Eight programmable chip selects
 - Supports Intel/Motorola* microprocessors
 - Multiplexed-style bus cycles
 - Simplex-style bus cycles
- DSP support for:
 - Texas Instruments* DSPs supporting HPI-8 bus cycles
 - Texas Instruments DSPs supporting HPI-16 bus cycles
- High-speed/Console UARTs
 - 1,200 baud to 921 Kbaud
 - 16550 compliant
 - 64-byte Tx and Rx FIFOs
 - CTS and RTS modem control signals
- Internal bus performance monitoring unit
 - Seven 27-bit event counters
 - Monitoring of internal bus occurrences and duration events
- 16 GPIOs
- Four internal timers
- Packaging
 - 492-pin PBGA
 - Commercial temperature (0° to +70° C)
 - Extended temperature (-40° to +85° C)

The remaining features described in the product line features list require software in order for these features to be functional. To determine if the feature is enabled, see the *Intel® IXP400 Software Programmer's Guide*.

- Three network processor engines (NPEs) **Note 1**
 - Used to offload typical Layer-2 networking functions such as:
 - Ethernet filtering
 - ATM SARing
 - HDLC
- Encryption/Authentication/Hashing **Note 1**
 - DES
 - Triple-DES (3DES)
 - AES 128-bit and 256-bit
 - ARC4/WEP-CRC
 - SHA-1
 - MD5
- Two MII interfaces **Note 1**
 - 802.3 MII interfaces



- Single MDIO interface to control both MII interfaces
- UTOPIA Level 2 Interface **Note 1**
 - Eight-bit interface
 - Up to 33 MHz clock speed
 - Five transmit and five receive address lines
- Two high-speed, serial interfaces **Note 1**
 - Six-wire
 - Supports speeds up to 8.192 MHz
 - Supports connection to T1/E1 framers
 - Supports connection to CODEC/SLICs
 - Eight HDLC Channels

Note: This feature requires Intel supplied software. To determine if this feature is enabled by a particular software release, see the *Intel® IXP400 Software Programmer's Guide*.

1.2.2 Processor Features

Table 3 on page 13 describes the features that apply to the Intel® IXP42X Product Line of Network Processors and IXC1100 Control Plane Processor.

Table 3. Processor Features (Sheet 1 of 2)

Feature	Requires Enabling Software (Note 1)	Intel® IXP425 Network Processor	Intel® IXP423 Network Processor	Intel® IXP422 Network Processor	Intel® IXP421 Network Processor	Intel® IXP420 Network Processor	Intel® IXC1100 Control Plane Processor
Processor Speed (MHz)		266/400/533	266/533	266	266	266/400/533	266/400/533
UTOPIA 2	Yes	X	X		X		
GPIO		X	X	X	X	X	X
UART 0/1		X	X	X	X	X	X
HSS 0	Yes	X	X		X		
HSS 1	Yes	X	X		X		
MII 0	Yes	X	X	X	X	X	X
MII 1	Yes	X	X	X		X	X
USB		X	X	X	X	X	X
PCI		X	X	X	X	X	X
Expansion Bus		16-bit, 66 MHz	16-bit, 66 MHz	16-bit, 66 MHz	16-bit, 66 MHz	16-bit, 66 MHz	16-bit, 66 MHz
SDRAM		32-bit, 133 MHz	32-bit, 133 MHz	32-bit, 133 MHz	32-bit, 133 MHz	32-bit, 133 MHz	32-bit, 133 MHz
AES / DES / 3DES	Yes	X		X			
Multi-Channel HDLC	Yes	8	8		8		
Notes:							
1. The features marked "Yes" require enabling software. Refer to the <i>Intel® IXP400 Software Programmer's Guide</i> to determine if the feature is enabled.							
2. Only the 266 MHz version of the Intel® IXP420 Network Processor supports extended temperature.							



Table 3. Processor Features (Sheet 2 of 2)

Feature	Requires Enabling Software (Note 1)	Intel® IXP425 Network Processor	Intel® IXP423 Network Processor	Intel® IXP422 Network Processor	Intel® IXP421 Network Processor	Intel® IXP420 Network Processor	Intel® IXC1100 Control Plane Processor
SHA-1 / MD-5	Yes	X		X			
Commercial Temperature		X	X	X	X	X	X
Extended Temperature		X				X (Note 2)	X

Notes:

1. The features marked "Yes" require enabling software. Refer to the *Intel® IXP400 Software Programmer's Guide* to determine if the feature is enabled.
2. Only the 266 MHz version of the Intel® IXP420 Network Processor supports extended temperature.

2.0 Functional Overview

The Intel® IXP42X Product Line of Network Processors and IXC1100 Control Plane Processor are compliant with the ARM[®] Version 5TE instruction-set architecture (ISA). The Intel® IXP42X product line and IXC1100 control plane processors are designed with Intel 0.18-micron production semiconductor process technology. This process technology — along with the compactness of the Intel XScale[®] processor, the ability to simultaneously process up to three integrated network processing engines (NPEs), and numerous dedicated-function peripheral interfaces — enables the IXP42X product line and IXC1100 control plane processors to operate over a wide range of low-cost networking applications, with industry-leading performance.

As indicated in [Figure 1](#) through [Figure 5](#), the Intel® IXP42X product line and IXC1100 control plane processors combine many features with the Intel XScale[®] Processor to create a highly integrated processor applicable to LAN/WAN-based networking applications in addition to other embedded networking applications.

This section briefly describes the main features of the product. For detailed functional descriptions, see the *Intel® IXP42X Product Line of Network Processors and IXC1100 Control Plane Processor Developer's Manual*.



Figure 1. Intel® IXP425 Network Processor Block Diagram

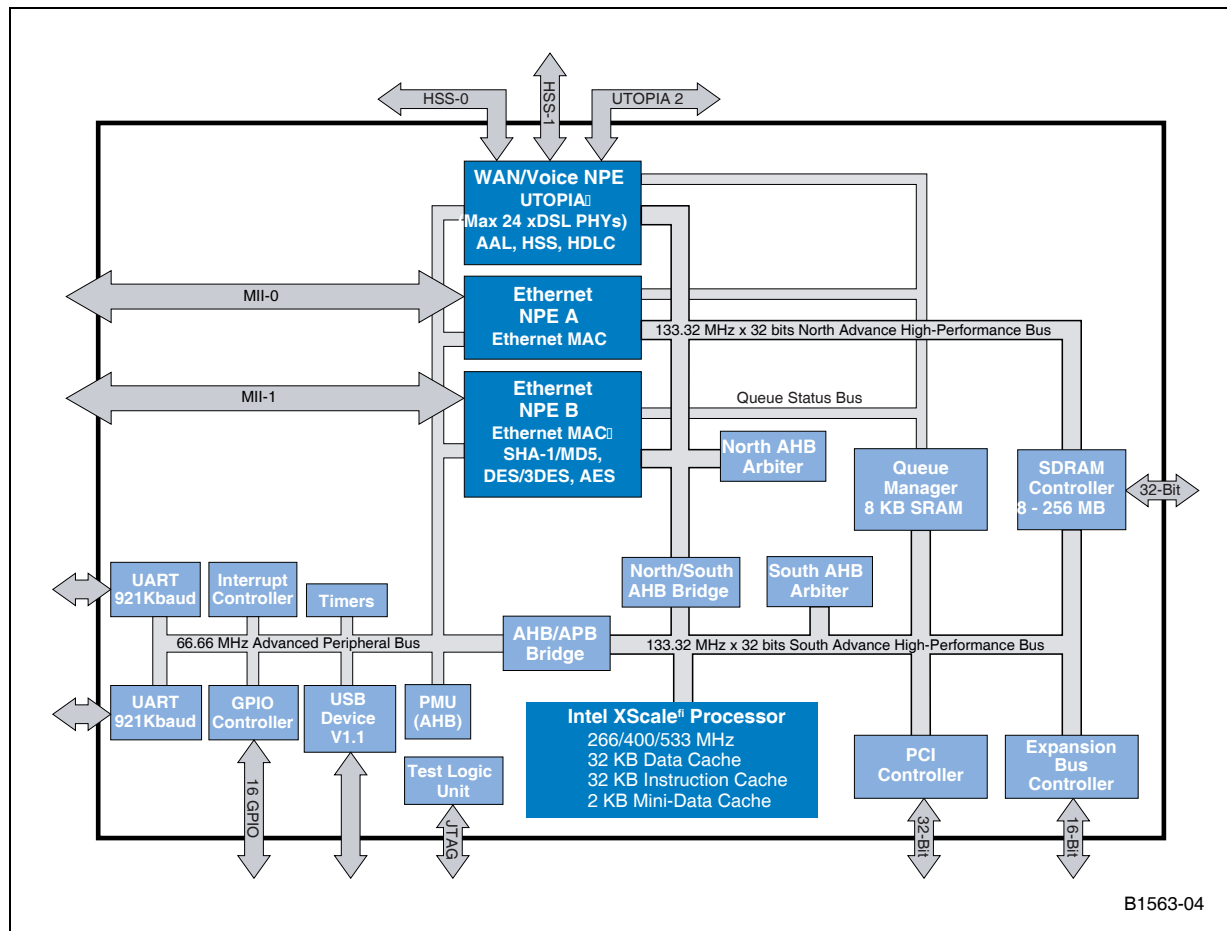

Figure 2. Intel® IXP423 Network Processor Block Diagram

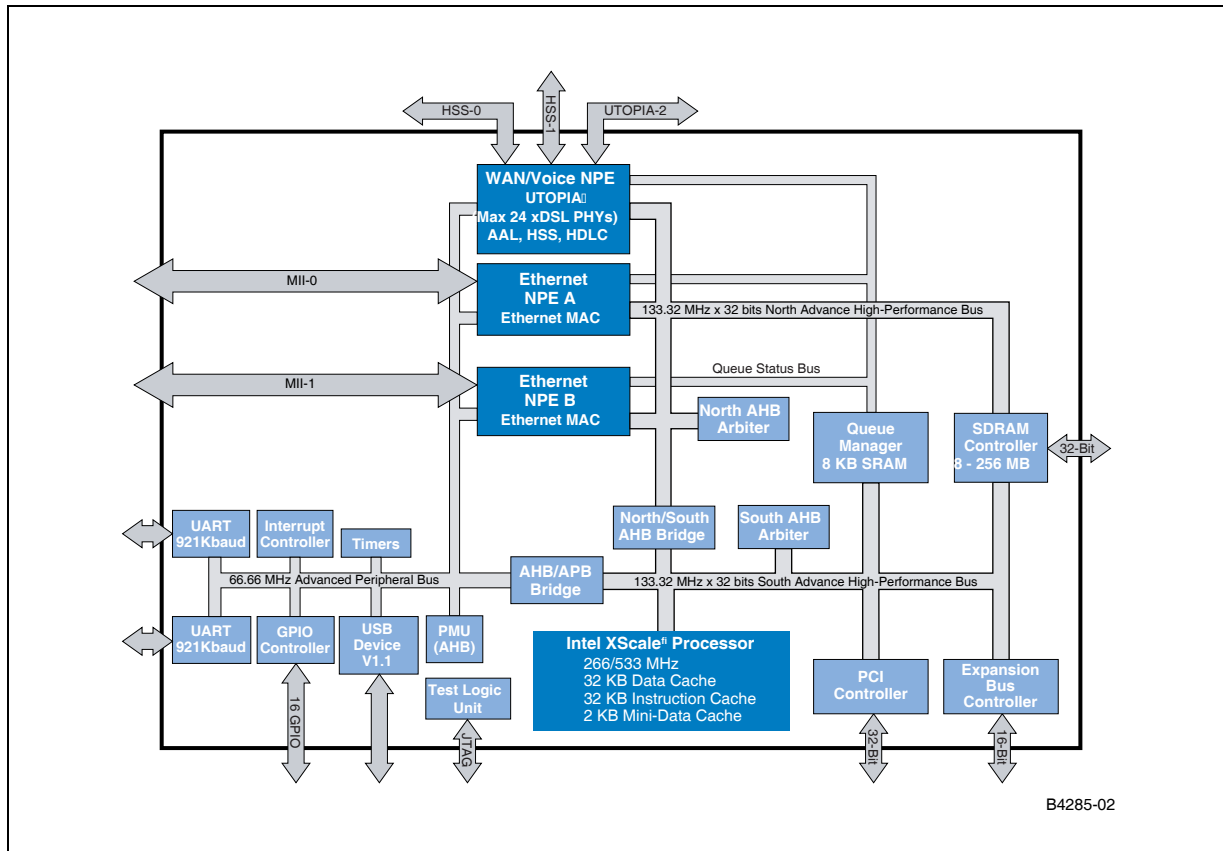



Figure 3. Intel® IXP422 Network Processor Block Diagram

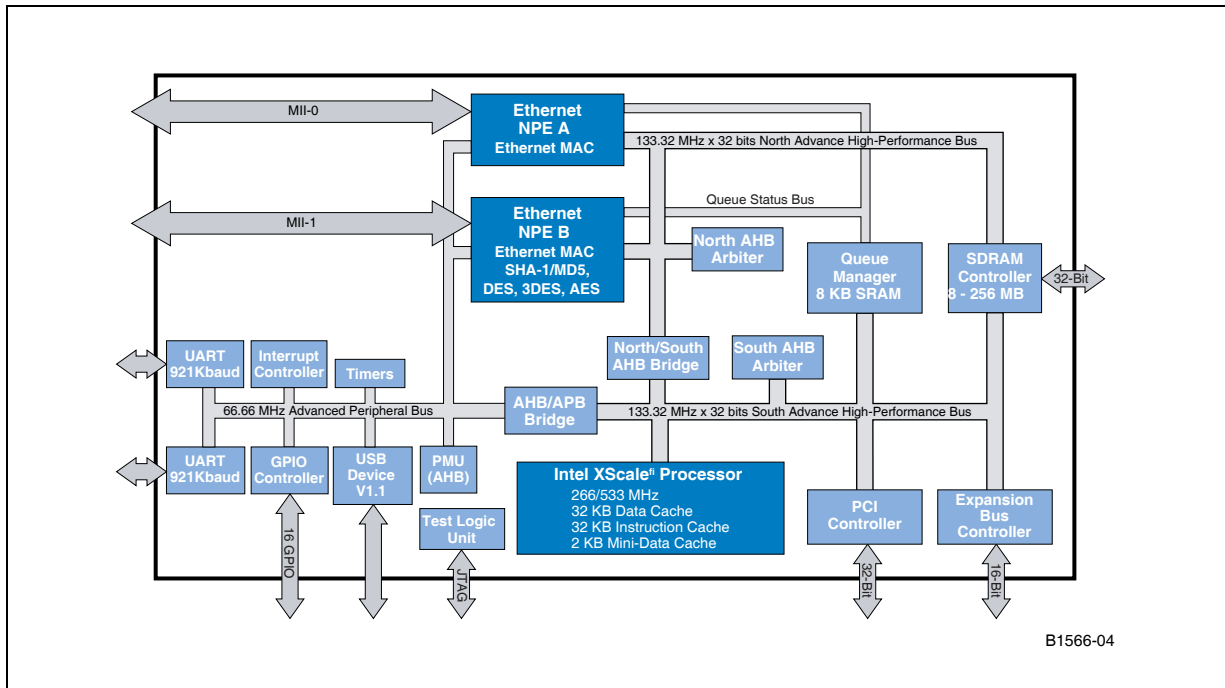

Figure 4. Intel® IXP421 Network Processor Block Diagram

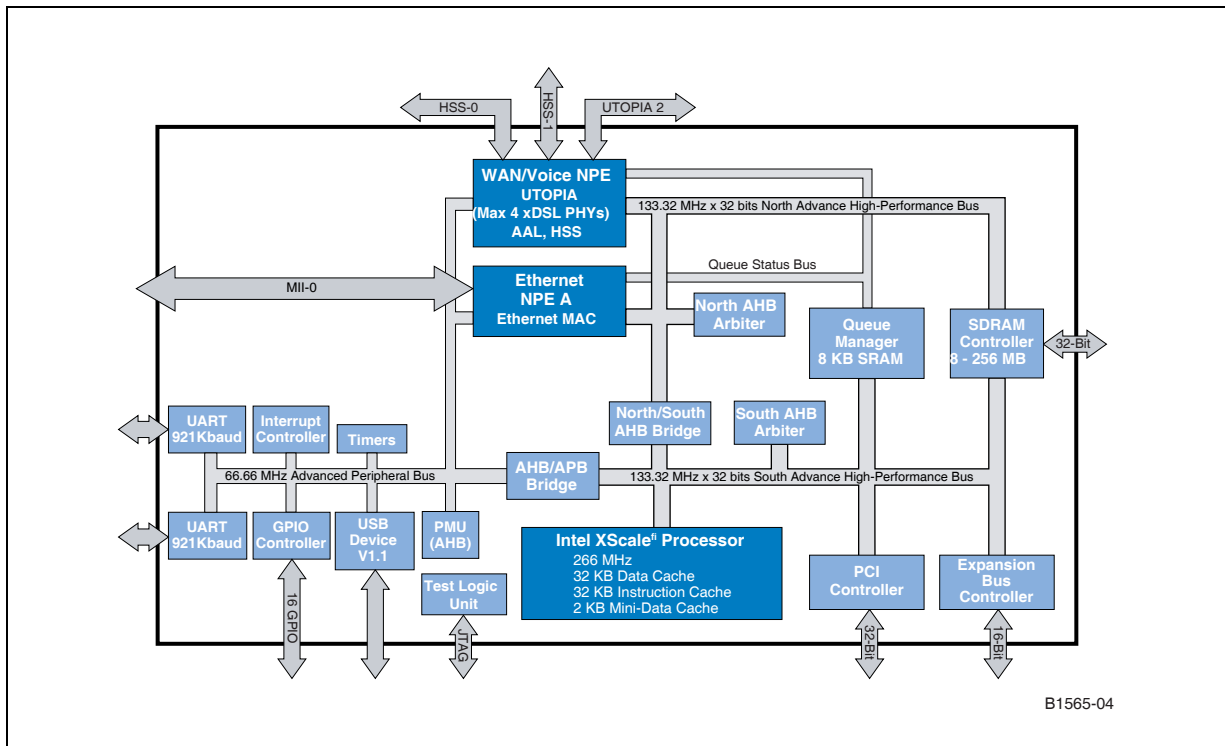
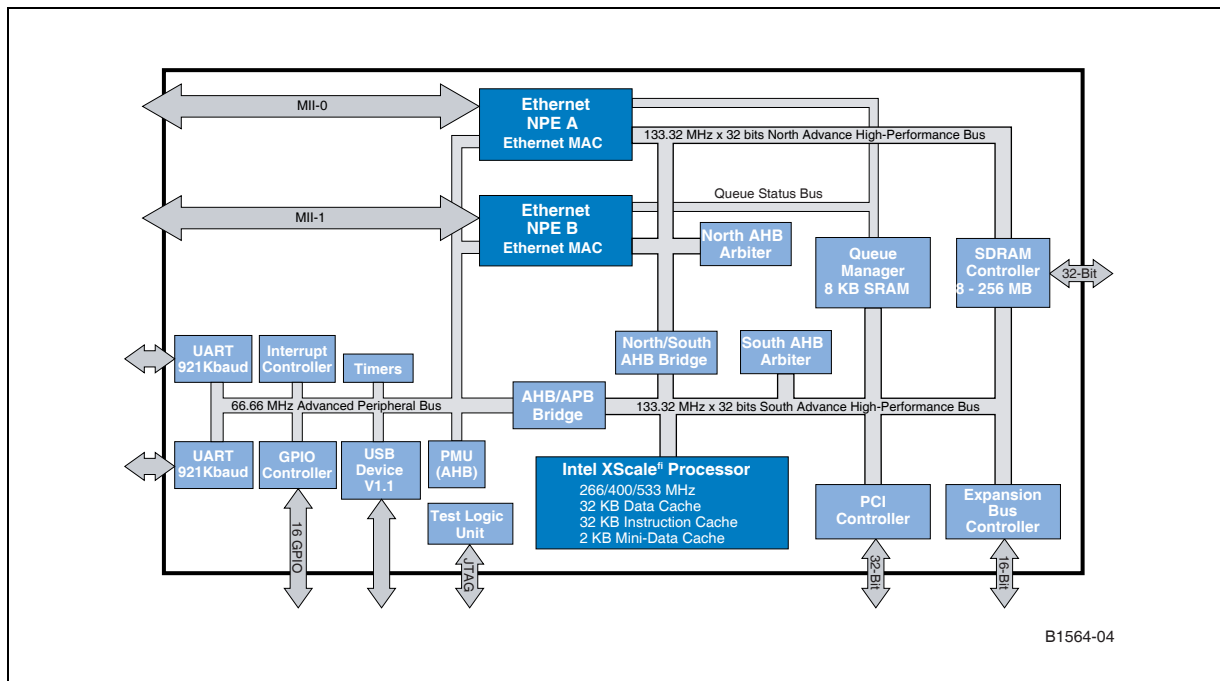

Figure 5. Intel® IXP420 Network Processor Block Diagram



2.1 Functional Units

The following sections briefly describe the functional units and their interaction in the system. For more detailed information, refer to the *Intel® IXP42X Product Line of Network Processors and IXC1100 Control Plane Processor Developer's Manual*.

Unless otherwise specified, the functional descriptions apply to all processors in the IXP42X product line and IXC1100 control plane processors. Refer to [Table 3 on page 13](#) and [Figure 1 on page 15](#) through [Figure 5](#) for specific information on supported interfaces.

2.1.1 Network Processor Engines (NPEs)

The network processor engines (NPEs) are dedicated-function processors containing hardware coprocessors integrated into the IXP42X product line and IXC1100 control plane processors. The NPEs are used to off-load processing functions required by the Intel XScale® processor.

These NPEs are high-performance, hardware-multi-threaded processors with additional local-hardware-assist functionality used to off-load highly processor-intensive functions such as MII (MAC), CRC checking/generation, AAL segmentation and re-assembly, AES, DES, 3DES, SHA-1, and MD5. All instruction code for the NPEs are stored locally with a dedicated instruction memory bus and dedicated data memory bus.

These NPEs support processing of the dedicated peripherals that can include:

- A Universal Test and Operation PHY Interface for ATM (UTOPIA) 2 interface
- Two High-Speed Serial (HSS) interfaces
- Two Media-Independent Interfaces (MII)



Table 4 specifies which devices, in the IXP42X product line and IXC1100 control plane processors, have which of these capabilities.

Table 4. Processor Functions

Device	UTOPIA	HSS	MII 0	MII 1	AES / DES / 3DES	Multi-Channel HDLC	SHA-1 / MD-5
Intel® IXP425 Network Processor	X	X	X	X	X	8	X
Intel® IXP423 Network Processor	X	X	X	X		8	
Intel® IXP422 Network Processor			X	X	X		X
Intel® IXP421 Network Processor	X	X	X			8	
Intel® IXP420 Network Processor			X	X			
Intel® IXC1100 Control Plane Processor			X	X			

The NPE is a hardware-multi-threaded processor engine that is used to accelerate functions that are difficult to achieve high performance in a standard RISC processor. Each NPE is a 133.32 MHz (which is 4 * OSC_IN input pin) processor core that has self-contained instruction memory and self-contained data memory that operate in parallel.

In addition to having separate instruction/data memory and local-code store, the NPE supports hardware multi-threading with support for multiple contexts. The support of hardware multi-threading creates an efficient processor engine with minimal processor stalls due to the ability of the processor to switch contexts in a single clock cycle, based on a prioritized/preemptive basis. The prioritized/preemptive nature of the context switching allows time-critical applications to be implemented in a low-latency fashion, which is required while processing multi-media applications.

The NPE also connects several hardware-based coprocessors that are used to implement functions that are difficult for a processor to implement. These functions include:

- Serialization/De-serialization
- DES/3DES/AES
- MD5
- CRC checking/generation
- SHA-1
- HDLC bit stuffing/de-stuffing

These coprocessors are implemented in hardware, enabling the coprocessors and the NPE processor core to operate in parallel.

The combined forces of the hardware multi-threading, local-code store, independent instruction memory, independent data memory, and parallel processing allows the Intel XScale® processor to be utilized for application purposes. The multi-processing capability of the peripheral interface functions allows unparalleled performance to be achieved by the application running on the Intel XScale® processor.

2.1.2 Internal Bus

The internal bus architecture of the IXP42X product line and IXC1100 control plane processors is designed to allow parallel processing to occur and to isolate bus utilization, based on particular traffic patterns. The bus is segmented into three major buses: the North AHB, South AHB, and APB.



2.1.2.1 North AHB

The North AHB is a 133.32 MHz, 32-bit bus that can be mastered by the NPEs. The targets of the North AHB can be the SDRAM or the AHB/AHB bridge. The AHB/AHB bridge allows the NPEs to access the peripherals and internal targets on the South AHB.

Data transfers by the NPEs on the North AHB to the South AHB are targeted predominately to the queue manager. Transfers to the AHB/AHB bridge may be “posted,” when writing, or “split,” when reading.

When a transaction is “posted,” a master on the North AHB requests a write to a peripheral on the South AHB. If the AHB/AHB Bridge has a free FIFO location, the write request will be transferred from the master on the North AHB to the AHB/AHB bridge. The AHB/AHB bridge will complete the write on the South AHB, when it can obtain access to the peripheral on the South AHB. The North AHB is released to complete another transaction.

When a transaction is “split,” a master on the North AHB requests a read of a peripheral on the South AHB. If the AHB/AHB bridge has a free FIFO location, the read request will be transferred from the master on the North AHB to the AHB/AHB bridge. The AHB/AHB bridge will complete the read on the South AHB, when it can obtain access to the peripheral on the South AHB.

Once the AHB/AHB bridge has obtained the read information from the peripheral on the South AHB, the AHB/AHB bridge notifies the arbiter, on the North AHB, that the AHB/AHB bridge has the data for the master that requested the “split” transfer. The master on the North AHB — that requested the split transfer — will arbitrate for the North AHB and transfer the read data from the AHB/AHB bridge. The North AHB is released to complete another transaction while the North AHB master — that requested the “split” transfer — waits for the data to arrive.

These “posting” and “splitting” transfers allow control of the North AHB to be given to another master on the North AHB — enabling the North AHB to achieve maximum efficiency. Transfers to the AHB/AHB bridge are considered to be small and infrequent, relative to the traffic passed between the NPEs on the North AHB and the SDRAM.

2.1.2.2 South AHB

The South AHB is a 133.32 MHz, 32-bit bus that can be mastered by the Intel XScale® processor, PCI controller, and the AHB/AHB bridge. The targets of the South AHB Bus can be the SDRAM, PCI interface, queue manager, expansion bus, or the APB/AHB bridge.

Accessing across the APB/AHB bridge allows interfacing to peripherals attached to the APB.

2.1.2.3 APB Bus

The APB Bus is a 66.66 MHz (which is 2 * OSC_IN input pin.), 32-bit bus that can be mastered by the AHB/APB bridge only. The targets of the APB bus can be:

- High-speed UART interface
- Console UART interface
- USB v1.1 interface
- All NPEs
- Internal bus performance monitoring unit (IBPMU)
- Interrupt controller
- GPIO
- Timers



The APB interface is also used as an alternate-path interface to the NPEs and is used for NPE code download and configuration.

2.1.3 MII Interfaces

Two industry-standard, media-independent interface (MII) interfaces are integrated into most of the IXP42X product line and IXC1100 control plane processors with separate media-access controllers and independent network processing engines. (See [Table 4 on page 19.](#))

The independent NPEs and MACs allow parallel processing of data traffic on the MII interfaces and off-loading of processing required by the Intel XScale® processor. The IXP42X product line and IXC1100 control plane processors are compliant with the IEEE, 802.3 specification.

In addition to two MII interfaces, the IXP42X product line and IXC1100 control plane processors include a single management data interface that is used to configure and control PHY devices that are connected to the MII interface.

2.1.4 UTOPIA Level 2

The integrated, UTOPIA Level 2 interface works with a network processing engine, for several of the IXP42X product line and IXC1100 control plane processors. (See [Table 4 on page 19.](#))

The UTOPIA Level 2 interface supports a single- or a multiple-physical-interface configuration with cell-level or octet-level handshaking. The network processing engine handles segmentation and reassembly of ATM cells, CRC checking/generation, and transfer of data to/from memory. This allows parallel processing of data traffic on the UTOPIA Level 2 interface, off-loading processor overhead required by the Intel XScale® processor.

The IXP42X product line and IXC1100 control plane processors are compliant with the ATM Forum, *UTOPIA Level-2 Specification*, Revision 1.0.

2.1.5 USB Interface

The integrated USB 1.1 interface is a device-only controller. The interface supports full-speed operation and 16 endpoints and includes an integrated transceiver.

There are:

- Six isochronous endpoints (three input and three output)
- One control endpoints
- Three interrupt endpoints
- Six bulk endpoints (three input and three output)

2.1.6 PCI Controller

The IXP42X product line and IXC1100 control plane processors' PCI controller is compatible with the *PCI Local Bus Specification*, Rev. 2.2. The PCI interface is 32-bit compatible bus and capable of operating as either a host or an option (that is, not the Host) For more information on PCI Controller support and configuration see the *Intel® IXP42X Product Line of Network Processors and IXC1100 Control Plane Processor Developer's Manual*.



2.1.7 SDRAM Controller

The memory controller manages the interface to external SDRAM memory chips. The interface:

- Operates at 133.32 MHz (which is 4 * OSC_IN input pin.)
- Supports eight open pages simultaneously
- Has two banks to support memory configurations from 8 Mbyte to 256 Mbyte

The memory controller only supports 32-bit memory. If a x16 memory chip is used, a minimum of two memory chips would be required to facilitate the 32-bit interface required by the IXP42X product line and IXC1100 control plane processors. A maximum of four SDRAM memory chips may be attached to the processors. For more information on SDRAM support and configuration see the *Intel® IXP42X Product Line of Network Processors and IXC1100 Control Plane Processor Developer's Manual*.

The memory controller internally interfaces to the North AHB and South AHB with independent interfaces. This architecture allows SDRAM transfers to be interleaved and pipelined to achieve maximum possible efficiency.

The maximum burst size supported to the SDRAM interface is eight 32-bit words. This burst size allows the best efficiency/fairness performance between accesses from the North AHB and the South AHB.

2.1.8 Expansion Bus

The expansion interface allows easy and — in most cases — glue-less connection to peripheral devices. It also provides input information for device configuration after reset. Some of the peripheral device types are flash, ATM control interfaces, and DSPs used for voice applications. (Some voice configurations can be supported by the HSS interfaces and the Intel XScale® processor, implementing voice-compression algorithms.)

The expansion bus interface is a 16-bit interface that allows an address range of 512 bytes to 16 Mbytes, using 24 address lines for each of the eight independent chip selects.

Accesses to the expansion bus interface consists of five phases. Each of the five phases can be lengthened or shortened by setting various configuration registers on a per-chip-select basis. This feature allows the IXP42X product line and IXC1100 control plane processors to connect to a wide variety of peripheral devices with varying speeds.

The expansion bus interface supports Intel or Motorola* microprocessor-style bus cycles. The bus cycles can be configured to be multiplexed address/data cycles or separate address/data cycles for each of the eight chip-selects.

Additionally, Chip Selects 4 through 7 can be configured to support Texas Instruments HPI-8 or HPI-16 style accesses for DSPs.

The expansion bus interface is an asynchronous interface to externally connected chips. However, a clock must be supplied to the IXP42X product line and IXC1100 control plane processors' expansion bus interface for the interface to operate. This clock can be driven from GPIO 15 or an external source. The maximum clock rate that the expansion bus interface can accept is 66.66 MHz.

At the de-assertion of reset, the 24-bit address bus is used to capture configuration information from the levels that are applied to the pins at this time. External pull-up/pull-down resistors are used to tie the signals to particular logic levels. For additional details, refer to Section 8 (Expansion Bus Controller) of the *Intel® IXP42X Product Line of Network Processors and IXC1100 Control Plane Processor Developer's Manual*.



2.1.9 High-Speed, Serial Interfaces

The high-speed, serial interfaces are six-signal interfaces that support serial transfer speeds from 512 KHz to 8.192 MHz, for some models of the IXP42X product line and IXC1100 control plane processors. (See [Table 4 on page 19.](#))

Each interface allows direct connection of up to four T1/E1 framers and CODEC/SLICs to the IXP42X product line and IXC1100 control plane processors. The high-speed, serial interfaces are capable of supporting various protocols, based on the implementation of the code developed for the network processor engine. For a list of supported protocols, see the *Intel® IXP400 Software Programmer's Guide*.

2.1.10 High-Speed and Console UARTs

The UART interfaces are 16550-compliant UARTs with the exception of transmit and receive buffers. Transmit and receive buffers are 64 bytes-deep versus the 16 bytes required by the 16550 UART specification.

The interface can be configured to support speeds from 1,200 baud to 921 Kbaud. The interface support configurations of:

- Five, six, seven, or eight data-bit transfers
- One or two stop bits
- Even, odd, or no parity

The request-to-send (RTS_N) and clear-to-send (CTS_N) modem control signals also are available with the interface for hardware flow control.

2.1.11 GPIO

16 GPIO pins are supported by the IXP42X product line and IXC1100 control plane processors. GPIO pins 0 through 15 can be configured to be general-purpose input or general-purpose output. Additionally, GPIO pins 0 through 12 can be configured to be an interrupt input.

GPIO Pin 14 and GPIO 15 can also be configured as a clock output. The output-clock configuration can be set at various speeds, up to 33.33 MHz, with various duty cycles. GPIO Pin 14 is configured as an input, upon reset. GPIO Pin 15 is configured as an output, upon reset. GPIO Pin 15 can be used to clock the expansion interface, after reset.

2.1.12 Internal Bus Performance Monitoring Unit (IBPMU)

The IXP42X product line and IXC1100 control plane processors consists of seven 27-bit counters that may be used to capture predefined durations or occurrence events on the North AHB, South AHB, or SDRAM controller page hits/misses.

2.1.13 Interrupt Controller

The IXP42X product line and IXC1100 control plane processors consists of 32 interrupt sources to allow an extension of the Intel XScale® processor FIQ and IRQ interrupt sources. These sources can originate from some external GPIO pins or internal peripheral interfaces.

The interrupt controller can configure each interrupt source as an FIQ, IRQ, or disabled. The interrupt sources tied to Interrupt 0 to 7 can be prioritized. The remaining interrupts are prioritized in ascending order. For example, Interrupt 8 has a higher priority than 9, 9 has a higher priority than 10, and 30 has a higher priority than 31.



2.1.14 Timers

The IXP42X product line and IXC1100 control plane processors consists of four internal timers operating at 66.66 MHz (which is 2 * OSC_IN input pin.) to allow task scheduling and prevent software lock-ups. The device has four 32-bit counters:

- Watch-Dog Timer
- Timestamp Timer
- Two general-purpose timers

2.1.15 AHB Queue Manager

The AHB Queue Manager (AQM) provides queue functionality for various internal blocks. It maintains the queues as circular buffers in an embedded 8KB SRAM. It also implements the status flags and pointers required for each queue.

The AQM manages 64 independent queues. Each queue is configurable for buffer and entry size. Additionally status flags are maintained for each queue.

The AQM interfaces include an Advanced High-performance Bus (AHB) interface to the NPEs and Intel XScale® processor (or any other AHB bus master), a Flag Bus interface, an event bus (to the NPE condition select logic) and two interrupts to the Intel XScale® processor. The AHB interface is used for configuration of the AQM and provides access to queues, queue status and SRAM. Individual queue status for queues 0-31 is communicated to the NPEs via the flag bus. Combined queue status for queues 32-63 are communicated to the NPEs via the event bus. The two interrupts, one for queues 0-31 and one for queues 32-63, provide status interrupts to the Intel XScale® processor.

2.2 Intel XScale® Processor

The Intel XScale technology is compliant with the ARM* Version 5TE instruction-set architecture (ISA). The Intel XScale® processor, shown in [Figure 6](#), is designed with Intel 0.18-micron production semiconductor process technology. This process technology enables the Intel XScale® processor to operate over a wide speed and power range, producing industry-leading mW/MIPS performance.

Intel XScale® processor features include:

- Seven/eight-stage super-pipeline promotes high-speed, efficient processor performance
- 128-entry branch target buffer keeps pipeline filled with statistically correct branch choices
- 32-entry instruction memory-management unit for logical-to-physical address translation, access permissions, I-cache attributes
- 32-entry data-memory management unit for logical-to-physical address translation, access permissions, D-cache attributes
- 32-Kbyte instruction cache can hold entire programs, preventing processor stalls caused by multi-cycle memory accesses
- 32-Kbyte data cache reduces processor stalls caused by multi-cycle memory accesses
- 2-Kbyte mini-data cache for frequently changing data streams avoids “thrashing” of the D-cache
- Four-entry fill-and-pend buffers to promote processor efficiency by allowing “hit-under-miss” operation with data caches
- Eight-entry write buffer allows the processor to continue execution while data is written to memory



- Multiple-accumulate coprocessor that can do two simultaneous, 16-bit, SIMD multiplies with 40-bit accumulation for efficient, high-quality media and signal processing
- Performance monitoring unit (PMU) furnishing two 32-bit event counters and one 32-bit cycle counter for analysis of hit rates, etc.
This PMU is for the Intel XScale® processor only. An additional PMU is supplied for monitoring of internal bus performance.
- JTAG debug unit that uses hardware break points and 256-entry trace history buffer (for flow-change messages) to debug programs

Figure 6. Intel XScale® Technology Block Diagram

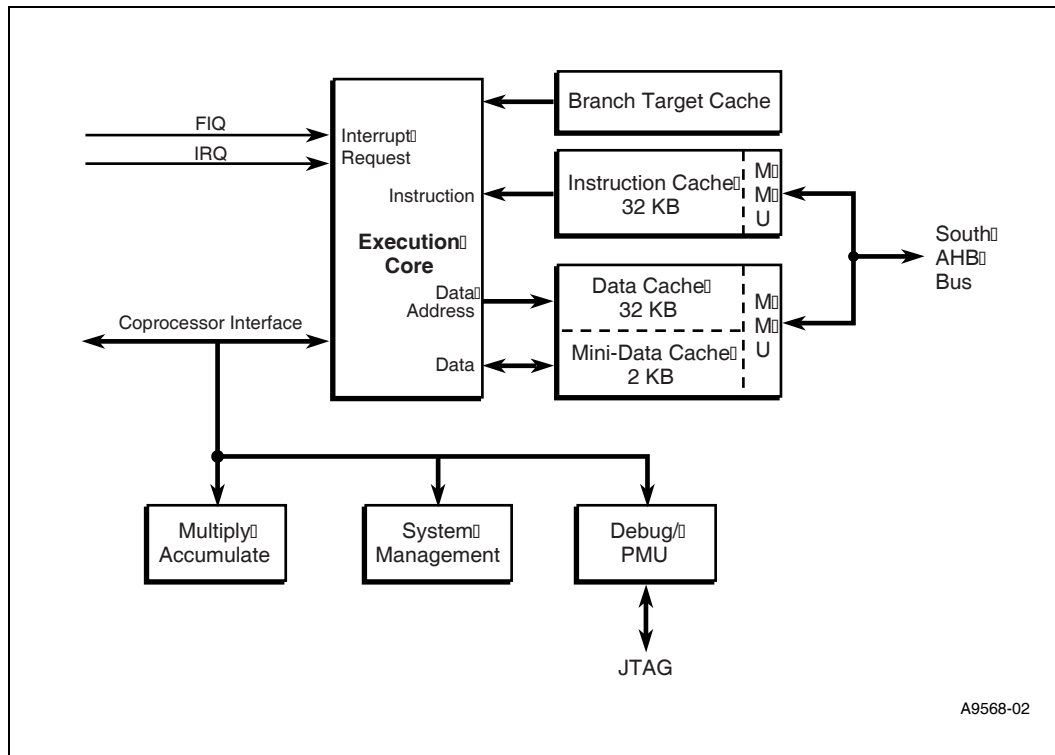

2.2.1 Super Pipeline

The super pipeline is composed of integer, multiply-accumulate (MAC), and memory pipes.

The integer pipe has seven stages:

- Branch Target Buffer (BTB)/Fetch 1
- Fetch 2
- Decode
- Register File/Shift
- ALU Execute
- State Execute
- Integer Writeback

The memory pipe has eight stages:



- The first five stages of the Integer pipe (BTB/Fetch 1 through ALU Execute) . . . then finish with the following memory stages:
- Data Cache 1
- Data Cache 2
- Data Cache Writeback

The MAC pipe has six to nine stages:

- The first four stages of the Integer pipe (BTB/Fetch 1 through Register File/ Shift) . . . then finish with the following MAC stages:
- MAC 1
- MAC 2
- MAC 3
- MAC 4
- Data Cache Writeback

The MAC pipe supports a data-dependent early terminate where stages MAC 2, MAC 3, and/or MAC 4 are bypassed.

Deep pipes promote high instruction execution rates only when a means exists to successfully predict the outcome of branch instructions. The branch target buffer provides such a means.

2.2.2 Branch Target Buffer (BTB)

Each entry of the 128-entry BTB contains the address of a branch instruction, the target address associated with the branch instruction, and a previous history of the branch being taken or not taken. The history is recorded as one of four states:

- Strongly taken
- Weakly taken
- Weakly not taken
- Strongly not taken

The BTB can be enabled or disabled via Coprocessor 15, Register 1.

When the address of the branch instruction hits in the BTB and its history is strongly or weakly taken, the instruction at the branch target address is fetched. When its history is strongly or weakly not-taken, the next sequential instruction is fetched. In either case the history is updated.

Data associated with a branch instruction enters the BTB the first time the branch is taken. This data enters the BTB in a slot with a history of strongly not-taken (overwriting previous data when present).

Successfully predicted branches avoid any branch-latency penalties in the super pipeline. Unsuccessfully predicted branches result in a four to five cycle branch-latency penalty in the super pipeline.

2.2.3 Instruction Memory Management Unit (IMMU)

For instruction pre-fetches, the IMMU controls logical-to-physical address translation, memory access permissions, memory-domain identifications, and attributes (governing operation of the instruction cache). The IMMU contains a 32-entry, fully associative instruction-translation, look-aside buffer (ITLB) that has a round-robin replacement policy. ITLB entries zero through 30 can be locked.



When an instruction pre-fetch misses in the ITLB, the IMMU invokes an automatic table-walk mechanism that fetches an associated descriptor from memory and loads it into the ITLB. The descriptor contains information for logical-to-physical address translation, memory-access permissions, memory-domain identifications, and attributes governing operation of the I-cache. The IMMU then continues the instruction pre-fetch by using the address translation just entered into the ITLB. When an instruction pre-fetch hits in the ITLB, the IMMU continues the pre-fetch using the address translation already resident in the ITLB.

Access permissions for each of up to 16 memory domains can be programmed. When an instruction pre-fetch is attempted to an area of memory in violation of access permissions, the attempt is aborted and a pre-fetch abort is sent to the Intel XScale® processor for exception processing. The IMMU and DMMU can be enabled or disabled together.

2.2.4 Data Memory Management Unit (DMMU)

For data fetches, the DMMU controls logical-to-physical address translation, memory-access permissions, memory-domain identifications, and attributes (governing operation of the data cache or mini-data cache and write buffer). The DMMU contains a 32-entry, fully associative data-translation, look-aside buffer (DTLB) that has a round-robin replacement policy. DTLB entries 0 through 30 can be locked.

When a data fetch misses in the DTLB, the DMMU invokes an automatic table-walk mechanism that fetches an associated descriptor from memory and loads it into the DTLB. The descriptor contains information for logical-to-physical address translation, memory-access permissions, memory-domain identifications, and attributes (governing operation of the D-cache or mini-data cache and write buffer).

The DMMU continues the data fetch by using the address translation just entered into the DTLB. When a data fetch hits in the DTLB, the DMMU continues the fetch using the address translation already resident in the DTLB.

Access permissions for each of up to 16 memory domains can be programmed. When a data fetch is attempted to an area of memory in violation of access permissions, the attempt is aborted and a data abort is sent to the Intel XScale® processor for exception processing.

The IMMU and DMMU can be enabled or disabled together.

2.2.5 Instruction Cache (I-Cache)

The I-cache can contain high-use, multiple-code segments or entire programs, allowing the Intel XScale® processor access to instructions at core frequencies. This prevents processor stalls caused by multi-cycle accesses to external memory.

The 32-Kbyte I-cache is 32-set/32-way associative, where each set contains 32 ways and each way contains a tag address, a cache line of instructions (eight 32-bit words and one parity bit per word), and a line-valid bit. For each of the 32 sets, 0 through 28 ways can be locked. Unlocked ways are replaceable via a round-robin policy.

The I-cache can be enabled or disabled. Attribute bits within the descriptors, contained in the ITLB of the IMMU, provide some control over an enabled I-cache.

When a needed line (eight 32-bit words) is not present in the I-cache, the line is fetched (critical word first) from memory via a two-level, deep-fetch queue. The fetch queue allows the next instruction to be accessed from the I-cache, but only when its data operands do not depend on the execution results of the instruction being fetched via the queue.



2.2.6 Data Cache (D-Cache)

The D-cache can contain high-use data such as lookup tables and filter coefficients, allowing the Intel XScale® processor access to data at core frequencies. This prevents processor stalls caused by multi-cycle accesses to external memory.

The 32-Kbyte D-cache is 32-set/32-way associative, where each set contains 32 ways and each way contains a tag address, a cache line (32 bytes with one parity bit per byte) of data, two dirty bits (one for each of two eight-byte groupings in a line), and one valid bit. For each of the 32 sets, zero through 28 ways can be locked, unlocked, or used as local SRAM. Unlocked ways are replaceable via a round-robin policy.

The D-cache (together with the mini-data cache) can be enabled or disabled. Attribute bits within the descriptors, contained in the DTLB of the DMMU, provide significant control over an enabled D-cache. These bits specify cache operating modes such as read and write allocate, write-back, write-through, and D-cache versus mini-data cache targeting.

The D-cache (and mini-data cache) work with the load buffer and pend buffer to provide “hit-under-miss” capability that allows the Intel XScale® processor to access other data in the cache after a “miss” is encountered. The D-cache (and mini-data cache) works in conjunction with the write buffer for data that is to be stored to memory.

2.2.7 Mini-Data Cache

The mini-data cache can contain frequently changing data streams such as MPEG video, allowing the Intel XScale® processor access to data streams at core frequencies. This prevents processor stalls caused by multi-cycle accesses to external memory. The mini-data cache relieves the D-cache of data “thrashing” caused by frequently changing data streams.

The 2-Kbyte, mini-data cache is 32-set/two-way associative, where each set contains two ways and each way contains a tag address, a cache line (32 bytes with one parity bit per byte) of data, two dirty bits (one for each of two eight-byte groupings in a line), and a valid bit. The mini-data cache uses a round-robin replacement policy, and cannot be locked.

The mini-data cache (together with the D-cache) can be enabled or disabled. Attribute bits contained within a coprocessor register specify operating modes write and/or read allocate, write-back, and write-through.

The mini-data cache (and D-cache) work with the load buffer and pend buffer to provide “hit-under-miss” capability that allows the Intel XScale® processor to access other data in the cache after a “miss” is encountered. The mini-data cache (and D-cache) works in conjunction with the write buffer for data that is to be stored to memory.

2.2.8 Fill Buffer (FB) and Pend Buffer (PB)

The four-entry fill buffer (FB) works with the Intel XScale® processor to hold non-cacheable loads until the bus controller can act on them. The FB and the four-entry pend buffer (PB) work with the D-cache and mini-data cache to provide “hit-under-miss” capability, allowing the Intel XScale® processor to seek other data in the caches while “miss” data is being fetched from memory.

The FB can contain up to four unique “miss” addresses (logical), allowing four “misses” before the processor is stalled. The PB holds up to four addresses (logical) for additional “misses” to those addresses that are already in the FB. A coprocessor register can specify draining of the fill and pend (write) buffers.



2.2.9 Write Buffer (WB)

The write buffer (WB) holds data for storage to memory until the bus controller can act on it. The WB is eight entries deep, where each entry holds 16 bytes. The WB is constantly enabled and accepts data from the Intel XScale® processor, D-cache, or mini-data cache.

Coprocessor 15, Register 1 specifies whether WB coalescing is enabled or disabled. When coalescing is disabled, stores to memory occur in program order regardless of the attribute bits within the descriptors located in the DTLB. When coalescing is enabled, the attribute bits within the descriptors located in the DTLB are examined to determine when coalescing is enabled for the destination region of memory. When coalescing is enabled in both CP15, R1 and the DTLB, data entering the WB can coalesce with any of the eight entries (16 bytes) and be stored to the destination memory region, but possibly out of program order.

Stores to a memory region specified to be non-cacheable and non-bufferable by the attribute bits within the descriptors located in the DTLB causes the processor to stall until the store completes. A coprocessor register can specify draining of the write buffer.

2.2.10 Multiply-Accumulate Coprocessor (CP0)

For efficient processing of high-quality, media-and-signal-processing algorithms, CP0 provides 40-bit accumulation of 16 x 16, dual-16 x 16 (SIMD), and 32 x 32 signed multiplies. Special MAR and MRA instructions are implemented to move the 40-bit accumulator to two Intel XScale® processor general registers (MAR) and move two Intel XScale® processor general registers to the 40-bit accumulator (MRA). The 40-bit accumulator can be stored or loaded to or from D-cache, mini-data cache, or memory using two STC or LDC instructions.

The 16 x 16 signed multiply-accumulates (MIAxy) multiply either the high/high, low/low, high/low, or low/high 16 bits of a 32-bit Intel XScale® processor general register (multiplier) and another 32-bit Intel XScale® processor general register (multiplicand) to produce a full, 32-bit product that is sign-extended to 40 bits and added to the 40-bit accumulator.

Dual-signed, 16 x 16 (SIMD) multiply-accumulates (MIAPH) multiply the high/high and low/low 16-bits of a packed 32-bit, Intel XScale® processor general register (multiplier) and another packed 32-bit, Intel XScale® processor general register (multiplicand) to produce two 16-bits products that are both sign-extended to 40 bits and added to the 40-bit accumulator.

The 32 x 32 signed multiply-accumulates (MIA) multiply a 32-bit, Intel XScale® processor general register (multiplier) and another 32-bit, Intel XScale® processor general register (multiplicand) to produce a 64-bit product where the 40 LSBs are added to the 40-bit accumulator. The 16 x 32 versions of the 32 x 32 multiply-accumulate instructions complete in a single cycle.

2.2.11 Performance Monitoring Unit (PMU)

The performance monitoring unit contains two 32-bit, event counters and one 32-bit, clock counter. The event counters can be programmed to monitor I-cache hit rate, data caches hit rate, ITLB hit rate, DTLB hit rate, pipeline stalls, BTB prediction hit rate, and instruction execution count.



2.2.12 Debug Unit

The debug unit is accessed through the JTAG port. The industry-standard, IEEE 1149.1 JTAG port consists of a test access port (TAP) controller, boundary-scan register, instruction and data registers, and dedicated signals TDI, TDO, TCK, TMS, and TRST#.

The debug unit — when used with debugger application code running on a host system outside of the Intel XScale® processor — allows a program, running on the Intel XScale® processor, to be debugged. It allows the debugger application code or a debug exception to stop program execution and redirect execution to a debug-handling routine.

Debug exceptions are instruction breakpoint, data breakpoint, software breakpoint, external debug breakpoint, exception vector trap, and trace buffer full breakpoint. Once execution has stopped, the debugger application code can examine or modify the Intel XScale® processor's state, coprocessor state, or memory. The debugger application code can then restart program execution.

The debug unit has two hardware-instruction, break point registers; two hardware, data-breakpoint registers; and a hardware, data-breakpoint control register. The second data-breakpoint register can be alternatively used as a mask register for the first data-breakpoint register.

A 256-entry trace buffer provides the ability to capture control flow messages or addresses. A JTAG instruction (LDIC) can be used to download a debug handler via the JTAG port to the mini-instruction cache (the I-cache has a 2-Kbyte, mini-instruction cache to hold a debug handler).

3.0 Functional Signal Descriptions

Listed in the signal definition tables — starting at [Table 7, “SDRAM Interface” on page 33](#) — are pull-up or pull-down resistor recommendations that are required when the particular *enabled* interface is not being used in the application. These external resistor requirements are only needed if the particular model of Intel® IXP42X product line and IXC1100 control plane processors has the particular interface *enabled* and the interface is not required in the application.

Warning: All IXP42X product line and IXC1100 control plane processors I/O pins are *not* 5-V tolerant.

Disabled features, within the IXP42X product line and IXC1100 control plane processors, do not require external resistors as the processor will have internal pull-up or pull-down resistors enabled as part of the *disabled* interface.

[Table 5](#) presents the legend for interpreting the **Type** field in the other tables in this section of the document.

To determine which interfaces are not enabled within the IXP42X product line and IXC1100 control plane processors, see [Table 3 on page 13](#).

Table 5. Signal Type Definitions (Sheet 1 of 2)

Symbol	Description
I	Input pin only
O	Output pin only
I/O	Pin can be either an input or output
OD	Open Drain pin



Table 5. Signal Type Definitions (Sheet 2 of 2)

Symbol	Description
PWR	Power pin
GND	Ground pin
1	Driven to Vcc
0	Driven to Vss
X	Driven to unknown state
ID	Input is disabled
H	Pulled up to Vcc
L	Pulled to Vss
PD	Pull-up Disabled
Z	Output Disabled
VO	A valid output level is driven, allowed states - 1, 0, H, Z
VI	Need to drive a valid input level, allowed states - 1, 0, H, Z
PE	Pull-up Enabled, equivalent to H
Tri	Output Only/Tristatable
N/C	No Connect
-	Pin must be connected as described

Table 6. Processors’ Signal Interface Summary Table

Reference
Table 7, “SDRAM Interface” on page 33
Table 8, “PCI Controller” on page 34
Table 9, “High-Speed, Serial Interface 0” on page 36
Table 10, “High-Speed, Serial Interface 1” on page 37
Table 11, “MII Interfaces” on page 38
Table 12, “UTOPIA Level 2 Interface” on page 40
Table 13, “Expansion Bus Interface” on page 41
Table 14, “UART Interfaces” on page 42
Table 15, “USB Interface” on page 43
Table 16, “Oscillator Interface” on page 44
Table 17, “GPIO Interface” on page 44
Table 18, “JTAG Interface” on page 45
Table 19, “System Interfacet†” on page 45
Table 20, “Power Interface” on page 46

3.1 Pin Description Tables

This section identifies all the signal pins by symbol name, type and description. Names should follow the following convention, all capital letters with a trailing “_N” indicate a signal is asserted when driven to a logic low (digital 0). The description includes the full name of the pin along with a functional description. This section does not specify the number of power and ground pins required, but does include the number of different types of power pins required.

A signal called active high specifies that the interface is active when driven to a logic 1 and inactive when driven to a logic 0.

A signal called active low specifies that the interface is active when driven to a logic 0 and inactive when driven to a logic 1.



The following information attempts to explain how to interpret the tables. There are five vertical columns:

- The **Power Reset** or **Sys Reset** column indicates signal state for the following conditions:
 - **Power Reset** is defined as follows:
 $PWRON_RESET_N = 0$ and $RESET_IN_N = X$
 - **Sys Reset** is defined as follows:
 $PWRON_RESET_N = 1$ and $RESET_IN_N = 0$
- The **Post Reset** column indicates signal state for the following condition:
 - **Post Reset** is defined as follows:
 $PWRON_RESET_N = 1$, $RESET_IN_N = 1$ and $PLL_LOCK = 1$



Functional Signal Descriptions

Table 7. SDRAM Interface

Name	Power Reset or Sys Reset	Post Reset	Type [†]	Description
SDM_ADDR[12:0]	Z	0	O	SDRAM Address: A0-A12 signals are output during the READ/WRITE commands and ACTIVE commands to select a location in memory to act upon.
SDM_DATA[31:0]	Z	1	I/O	SDRAM Data: Bidirectional data bus used to transfer data to and from the SDRAM
SDM_CLKOUT	Z	0	O	SDRAM Clock: All SDRAM input signals are sampled on the rising edge of SDM_CLKOUT. All output signals are driven with respect to the rising edge of SDM_CLKOUT.
SDM_BA[1:0]	Z	0	O	SDRAM Bank Address: SDM_BA0 and SDM_BA1 define the bank the current command is attempting to access.
SDM_RAS_N	Z	1	O	SDRAM Row Address strobe/select (active low): Along with SDM_CAS_N, SDM_WE_N, and SDM_CS_N signals determines the current command to be executed.
SDM_CAS_N	Z	1	O	SDRAM Column Address strobe/select (active low): Along with SDM_RAS_N, SDM_WE_N, and SDM_CS_N signals determines the current command to be executed.
SDM_CS_N[1:0]	Z	1	O	SDRAM Chip select (active low): CS# enables the command decoder in the external SDRAM when logic low and disables the command decoder in the external SDRAM when logic high.
SDM_WE_N	Z	1	O	SDRAM Write enable (active low): Along with SDM_CAS_N, SDM_RAS_N, and SDM_CS_N signals determines the current command to be executed.
SDM_CKE	Z	1	O	SDRAM Clock Enable: CKE is driving high to activate the clock to an external SDRAM and driven low to deactivate the CLK to an external SDRAM.
SDM_DQM[3:0]	Z	0	O	SDRAM Data bus mask: DQM is used to byte select data during read/write access to an external SDRAM.
† For a legend of the Type codes, see Table 5 on page 30 .				



Functional Signal Descriptions

Table 8. PCI Controller (Sheet 1 of 2)

Name	Power Reset or Sys Reset	Post Reset	Type [†]	Description
PCI_AD[31:0]	Z	Z	I/O	PCI Address/Data bus used to transfer address and bidirectional data to and from multiple PCI devices. Should be pulled high ^{††} with a 10-K Ω resistor when not being utilized in the system.
PCI_CBE_N[3:0]	Z	Z	I/O	PCI Command/Byte Enables is used as a command word during PCI address cycles and as byte enables for data cycles. Should be pulled high with a 10-K Ω resistor when not being utilized in the system.
PCI_PAR	Z	Z	I/O	PCI Parity used to check parity across the 32 bits of PCI_AD and the four bits of PCI_CBE_N. Should be pulled high ^{††} with a 10-K Ω resistor when not being utilized in the system.
PCI_FRAME_N	Z	Z	I/O	PCI Cycle Frame used to signify the beginning and duration of a transaction. The signal will be inactive prior to or during the final data phase of a given transaction. Should be pulled high with a 10-K Ω resistor when not being utilized in the system.
PCI_TRDY_N	Z	Z	I/O	PCI Target Ready informs that the target of the PCI bus is ready to complete the current data phase of a given transaction. Should be pulled high with a 10-K Ω resistor when not being utilized in the system.
PCI_IRDY_N	Z	Z	I/O	PCI Initiator Ready informs the PCI bus that the initiator is ready to complete the transaction. Should be pulled high with a 10-K Ω resistor when not being utilized in the system.
PCI_STOP_N	Z	Z	I/O	PCI Stop indicates that the current target is requesting the current initiator to stop the current transaction. Should be pulled high with a 10-K Ω resistor when not being utilized in the system.
PCI_PERR_N	Z	Z	I/O	PCI Parity Error asserted when a PCI parity error is detected — between the PCI_PAR and associated information on the PCI_AD bus and PCI_CBE_N — during all PCI transactions, except for Special Cycles. The agent receiving data will drive this signal. Should be pulled high with a 10-K Ω resistor when not being utilized in the system.
PCI_SERR_N	Z	Z	I/OD	PCI System Error asserted when a parity error occurs on special cycles or any other error that will cause the PCI bus not to function properly. This signal can function as an input or an open drain output. Should be pulled high with a 10-K Ω resistor when not being utilized in the system.
PCI_DEVSEL_N	Z	Z	I/O	PCI Device Select: <ul style="list-style-type: none"> When used as an output, PCI_DEVSEL_N indicates that device has decoded that address as the target of the requested transaction. When used as an input, PCI_DEVSEL_N indicates if any device on the PCI bus exists with the given address. Should be pulled high with a 10-K Ω resistor when not being utilized in the system.
PCI_IDSEL	Z	Z	I	PCI Initialization Device Select is a chip select during configuration reads and writes. Should be pulled high with a 10-K Ω resistor when not being utilized in the system.
PCI_REQ_N[3:1]	Z	Z	I	PCI arbitration request: Used by the internal PCI arbiter to allow an agent to request the PCI bus. Should be pulled high with a 10-K Ω resistor when not being utilized in the system.
†	For a legend of the Type codes, see Table 5 on page 30 .			
††	For new designs, this signal should be pulled high with a 10-K Ω resistor when not being utilized in the system. No change is required to existing designs that have this signal pulled low.			



Functional Signal Descriptions

Table 8. PCI Controller (Sheet 2 of 2)

Name	Power Reset or Sys Reset	Post Reset	Type [†]	Description
PCI_REQ_N[0]	Z	Z	I/O	PCI arbitration request: <ul style="list-style-type: none"> When configured as an input (PCI arbiter enabled), the internal PCI arbiter will allow an agent to request the PCI bus. When configured as an output (PCI arbiter disabled), the pin will be used to request access to the PCI bus from an external arbiter. Should be pulled high with a 10-K Ω resistor, when the PCI bus is not being utilized in the system.
PCI_GNT_N[3:1]	Z	Z	O	PCI arbitration grant: Generated by the internal PCI arbiter to allow an agent to claim control of the PCI bus.
PCI_GNT_N[0]	Z	Z	I/O	PCI arbitration grant: <ul style="list-style-type: none"> When configured as an output (PCI arbiter enabled), the internal PCI arbiter to allow an agent to claim control of the PCI bus. When configured as an input (PCI arbiter disabled), the pin will be used to claim access of the PCI bus from an external arbiter. Should be pulled high with a 10-K Ω resistor when not being utilized in the system.
PCI_INTA_N	Z	Z	O/D	PCI interrupt: Used to request an interrupt. Should be pulled high with a 10-K Ω resistor when not being utilized in the system.
PCI_CLKIN	Z	VI	I	PCI Clock: provides timing for all transactions on PCI. All PCI signals — except INTA#, INTB#, INTC#, and INTD# — are sampled on the rising edge of CLK and timing parameters are defined with respect to this edge. The PCI clock rate can operate at up to 66 MHz. Should be pulled high ^{††} with a 10-K Ω resistor when not being utilized in the system.
[†] For a legend of the Type codes, see Table 5 on page 30 . ^{††} For new designs, this signal should be pulled high with a 10-K Ω resistor when not being utilized in the system. No change is required to existing designs that have this signal pulled low.				



Functional Signal Descriptions

Table 9. High-Speed, Serial Interface 0

Name	Power Reset or Sys Reset	Post Reset	Type [†]	Description
HSS_TXFRAME0	Z	Z	I/O	The High-Speed Serial (HSS) transmit frame signal can be configured as an input or an output to allow an external source become synchronized with the transmitted data. Often known as a Frame Sync signal. Configured as an input upon reset. Should be pulled high ^{††} with a 10-K Ω resistor when not being utilized in the system.
HSS_TXDATA0	Z	Z	O/D	Transmit data out. Open Drain output. Must be pulled high with a 10-K Ω resistor to V _{CCP} .
HSS_TXCLK0	Z	Z	I/O	The High-Speed Serial (HSS) transmit clock signal can be configured as an input or an output. The clock can be a frequency ranging from 512 KHz to 8.192 MHz. Used to clock out the transmitted data. Configured as an input upon reset. Frame sync and data can be selected to be generated on the rising or falling edge of the transmit clock. Should be pulled high ^{††} with a 10-K Ω resistor when not being utilized in the system.
HSS_RXFRAME0	Z	Z	I/O	The High-Speed Serial (HSS) receive frame signal can be configured as an input or an output to allow an external source to become synchronized with the received data. Often known as a Frame Sync signal. Configured as an input upon reset. Should be pulled high ^{††} with a 10-K Ω resistor when not being utilized in the system.
HSS_RXDATA0	Z	VI	I	Receive data input. Can be sampled on the rising or falling edge of the receive clock. Should be pulled high ^{††} through a 10-K Ω resistor when not being utilized in the system.
HSS_RXCLK0	Z	Z	I/O	The High-Speed Serial (HSS) receive clock signal can be configured as an input or an output. The clock can be from 512 KHz to 8.192 MHz. Used to sample the received data. Configured as an input upon reset. Should be pulled high ^{††} with a 10-K Ω resistor when not being utilized in the system.
[†]	For a legend of the Type codes, see Table 5 on page 30 .			
^{††}	For new designs, this signal should be pulled high with a 10-K Ω resistor when not being utilized in the system. No change is required to existing designs that have this signal pulled low.			



Functional Signal Descriptions

Table 10. High-Speed, Serial Interface 1

Name	Power Reset or Sys Reset	Post Reset	Type [†]	Description
HSS_TXFRAME1	Z	Z	I/O	The High-Speed Serial (HSS) transmit frame signal can be configured as an input or an output to allow an external source to be synchronized with the transmitted data. Often known as a Frame Sync signal. Configured as an input upon reset. Should be pulled high ^{††} with a 10-K Ω resistor when not being utilized in the system.
HSS_TXDATA1	Z	Z	O/D	Transmit data out. Open Drain output. Must be pulled high with a 10-K Ω resistor to V_{CCP} .
HSS_TXCLK1	Z	Z	I/O	The High-Speed Serial (HSS) transmit clock signal can be configured as an input or an output. The clock can be a frequency ranging from 512 KHz to 8.192 MHz. Used to clock out the transmitted data. Configured as an input upon reset. Frame sync and Data can be selected to be generated on the rising or falling edge of the transmit clock. Should be pulled high ^{††} with a 10-K Ω resistor when not being utilized in the system.
HSS_RXFRAME1	Z	Z	I/O	The High-Speed Serial (HSS) receive frame signal can be configured as an input or an output to allow an external source to be synchronized with the received data. Often known as a Frame Sync signal. Configured as an input upon reset. Should be pulled high ^{††} with a 10-K Ω resistor when not being utilized in the system.
HSS_RXDATA1	Z	VI	I	Receive data input. Can be sampled on the rising or falling edge of the receive clock. Should be pulled high ^{††} through a 10-K Ω resistor when not being utilized in the system.
HSS_RXCLK1	Z	Z	I/O	The High-Speed Serial (HSS) receive clock signal can be configured as an input or an output. The clock can be from 512 KHz to 8.192 MHz. Used to sample the received data. Configured as an input upon reset. Should be pulled high ^{††} with a 10-K Ω resistor when not being utilized in the system.
[†]	For a legend of the Type codes, see Table 5 on page 30 .			
^{††}	For new designs, this signal should be pulled high with a 10-K Ω resistor when not being utilized in the system. No change is required to existing designs that have this signal pulled low.			



Functional Signal Descriptions

Table 11. MII Interfaces (Sheet 1 of 2)

Name	Power Reset or Sys Reset	Post Reset	Type [†]	Description
ETH_TXCLK0	Z	VI	I	Externally supplied transmit clock. <ul style="list-style-type: none"> • 25 MHz for 100 Mbps operation • 2.5 MHz for 10 Mbps Should be pulled high ^{††} through a 10-K Ω resistor when not being utilized in the system.
ETH_TXDATA0[3:0]	Z	O	O	Transmit data bus to PHY, asserted synchronously with respect to ETH_TXCLK0.
ETH_TXENO	Z	O	O	Indicates that the PHY is being presented with nibbles on the MII interface. Asserted synchronously, with respect to ETH_TXCLK0, at the first nibble of the preamble and remains asserted until all the nibbles of a frame are presented.
ETH_RXCLK0	Z	VI	I	Externally supplied receive clock. <ul style="list-style-type: none"> • 25 MHz for 100 Mbps operation • 2.5 MHz for 10 Mbps Should be pulled high ^{††} through a 10-K Ω resistor when not being utilized in the system.
ETH_RXDATA0[3:0]	Z	VI	I	Receive data bus from PHY, data sampled synchronously with respect to ETH_RXCLK0 <ul style="list-style-type: none"> • Should be pulled high^{††} through a 10-KΩ resistor when not being utilized in the system.
ETH_RXDVO	Z	VI	I	Receive data valid, used to inform the MII interface that the Ethernet PHY is sending data. Should be pulled high ^{††} through a 10-K Ω resistor when not being utilized in the system.
ETH_COLO	Z	VI	I	Asserted by the PHY when a collision is detected by the PHY. Should be pulled low through a 10-K Ω resistor when not being utilized in the system.
ETH_CRSD	Z	VI	I	Asserted by the PHY when the transmit medium or receive medium is active. De-asserted when both the transmit and receive medium are idle. Remains asserted throughout the duration of a collision condition. PHY asserts CRS asynchronously and de-asserts synchronously, with respect to ETH_RXCLK0. Should be pulled high ^{††} through a 10-K Ω resistor when not being utilized in the system.
ETH_MDIO	Z	Z	I/O	Management data output. Provides the write data to both PHY devices connected to each MII interface. An external 1.5-K Ω pull-up resistor is required. Note: If interfacing with a single Intel [®] LXT972 Fast Ethernet Transceiver, and a 1.5K pull-up resistor is not used, the NPE will 'see' 32 PHYs on the MII interface. Should be pulled high ^{††} through a 10-K Ω resistor when not being utilized in the system.
ETH_MDC	Z	Z	IO	Management data clock. Management data interface clock is used to clock the MDIO signal as an output and sample the MDIO as an input. The ETH_MDC is an input on power up and can be configured to be an output through an Intel API as documented in the <i>Intel[®] IXP400 Software Programmer's Guide</i> .
†	For a legend of the Type codes, see Table 5 on page 30.			
††	For new designs, this signal should be pulled high with a 10-K Ω resistor when not being utilized in the system. No change is required to existing designs that have this signal pulled low.			



Functional Signal Descriptions

Table 11. MII Interfaces (Sheet 2 of 2)

Name	Power Reset or Sys Reset	Post Reset	Type [†]	Description
ETH_TXCLK1	Z	VI	I	Externally supplied transmit clock. <ul style="list-style-type: none"> • 25 MHz for 100 Mbps operation • 2.5 MHz for 10 Mbps Should be pulled high ^{††} through a 10-K Ω resistor when not being utilized in the system.
ETH_TXDATA1[3:0]	Z	O	O	Transmit data bus to PHY, asserted synchronously with respect to ETH_TXCLK1.
ETH_TXEN1	Z	O	O	Indicates that the PHY is being presented with nibbles on the MII interface. Asserted synchronously, with respect to ETH_TXCLK1, at the first nibble of the preamble, and remains asserted until all the nibbles of a frame are presented.
ETH_RXCLK1	Z	VI	I	Externally supplied receive clock. <ul style="list-style-type: none"> • 25 MHz for 100 Mbps operation • 2.5 MHz for 10 Mbps Should be pulled high ^{††} through a 10-K Ω resistor when not being utilized in the system.
ETH_RXDATA1[3:0]	Z	VI	I	Receive data bus from PHY, data sampled synchronously, with respect to ETH_RXCLK1. <ul style="list-style-type: none"> • Should be pulled high^{††} through a 10-KΩ resistor when not being utilized in the system.
ETH_RXDV1	Z	VI	I	Receive data valid, used to inform the MII interface that the Ethernet PHY is sending data. Should be pulled high ^{††} through a 10-K Ω resistor when not being utilized in the system.
ETH_COL1	Z	VI	I	Asserted by the PHY when a collision is detected by the PHY. <ul style="list-style-type: none"> • Should be pulled low through a 10-KΩ resistor when not being utilized in the system.
ETH_CRS1	Z	VI	I	Asserted by the PHY when the transmit medium or receive medium are active. De-asserted when both the transmit and receive medium are idle. Remains asserted throughout the duration of collision condition. PHY asserts CRS asynchronously and de-asserts synchronously with respect to ETH_RXCLK1. Should be pulled high ^{††} through a 10-K Ω resistor when not being utilized in the system.
[†]	For a legend of the Type codes, see Table 5 on page 30 .			
^{††}	For new designs, this signal should be pulled high with a 10-K Ω resistor when not being utilized in the system. No change is required to existing designs that have this signal pulled low.			



Functional Signal Descriptions

Table 12. UTOPIA Level 2 Interface (Sheet 1 of 2)

Name	Power Reset or Sys Reset	Post Reset	Type†	Description
UTP_OP_CLK	Z	VI	I	UTOPIA Transmit clock input. Also known as UTP_TX_CLK. This signal is used to synchronize all UTOPIA-transmit outputs to the rising edge of the UTP_OP_CLK. This signal should be pulled high†† through a 10-KΩ resistor when not being utilized in the system.
UTP_OP_FCO	Z	Z	O	UTOPIA flow control output signal. Also known as the TXENB_N signal. Used to inform the selected PHY that data is being transmitted to the PHY. Placing the PHY's address on the UTP_OP_ADDR — and bringing UTP_OP_FCO to logic 1, during the current clock — followed by the UTP_OP_FCO going to a logic 0, on the next clock cycle, selects which PHY is active in MPHY mode. In SPHY configurations, UTP_OP_FCO is used to inform the PHY that the processor is ready to send data.
UTP_OP_SOC	Z	Z	O	Start of Cell. Also known as TX_SOC. Active high signal is asserted when UTP_OP_DATA contains the first valid byte of a transmitted cell.
UTP_OP_DATA[7:0]	Z	Z	O	UTOPIA output data. Also known as UTP_TX_DATA. Used to send data from the processor to an ATM UTOPIA-Level-2-compliant PHY.
UTP_OP_ADDR[4:0]	Z	VI	I/O	Transmit PHY address bus. Used by the processor when operating in MPHY mode to poll and select a single PHY at any given time.
UTP_OP_FCI	Z	VI	I	UTOPIA Output data flow control input: Also known as the TXFULL/CLAV signal. Used to inform the processor of the ability of each polled PHY to receive a complete cell. For cell-level flow control in an MPHY environment, TxClav is an active high tri-stateable signal from the MPHY to ATM layer. The UTP_OP_FCI, which is connected to multiple MPHY devices, will see logic high generated by the PHY, one clock after the given PHY address is asserted — when a full cell can be received by the PHY. The UTP_OP_FCI will see a logic low generated by the PHY one clock cycle, after the PHY address is asserted — if a full cell cannot be received by the PHY. This signal should be pulled high†† through a 10-KΩ resistor if not being used.
UTP_IP_CLK	Z	VI	I	UTOPIA Receive clock input. Also known as UTP_RX_CLK. This signal is used to synchronize all UTOPIA-received inputs to the rising edge of the UTP_IP_CLK. This signal should be pulled high†† through a 10-KΩ resistor when not being utilized in the system.
UTP_IP_FCI	Z	VI	I	UTOPIA Input Data flow control input signal. Also known as RXEMPTY/CLAV. Used to inform the processor of the ability of each polled PHY to send a complete cell. For cell-level flow control in an MPHY environment, RxClav is an active high tri-stateable signal from the MPHY to ATM layer. The UTP_IP_FCI, which is connected to multiple MPHY devices, will see logic high generated by the PHY, one clock after the given PHY address is asserted, when a full cell can be received by the PHY. The UTP_IP_FCI will see a logic low generated by the PHY, one clock cycle after the PHY address is asserted if a full cell cannot be received by the PHY. In SPHY mode, this signal is used to indicate to the processor that the PHY has an octet or cell available to be transferred to the processor. Should be pulled high†† through a 10-KΩ resistor when not being utilized in the system.
†	For a legend of the Type codes, see Table 5 on page 30 .			
††	For new designs, this signal should be pulled high with a 10-KΩ resistor when not being utilized in the system. No change is required to existing designs that have this signal pulled low.			



Functional Signal Descriptions

Table 12. UTOPIA Level 2 Interface (Sheet 2 of 2)

Name	Power Reset or Sys Reset	Post Reset	Type†	Description
UTP_IP_SOC	Z	VI	I	Start of Cell. RX_SOC Active-high signal that is asserted when UTP_IP_DATA contains the first valid byte of a transmitted cell. Should be pulled high†† through a 10-K Ω resistor when not being utilized in the system.
UTP_IP_DATA[7:0]	Z	VI	I	UTOPIA input data. Also known as RX_DATA. Used by to the processor to receive data from an ATM UTOPIA-Level-2-compliant PHY. Should be pulled high†† through a 10-K Ω resistor when not being utilized in the system.
UTP_IP_ADDR[4:0]	Z	VI	I/O	Receive PHY address bus. Used by the processor when operating in MPHY mode to poll and select a single PHY at any one given time.
UTP_IP_FCO	Z	Z	O	UTOPIA Input Data Flow Control Output signal: Also known as the RX_ENB_N. In SPHY configurations, UTP_IP_FCO is used to inform the PHY that the processor is ready to accept data. In MPHY configurations, UTP_IP_FCO is used to select which PHY will drive the UTP_RX_DATA and UTP_RX_SOC signals. The PHY is selected by placing the PHY's address on the UTP_IP_ADDR and bringing UTP_OP_FCO to logic 1 during the current clock, followed by the UTP_OP_FCO going to a logic 0 on the next clock cycle.
† For a legend of the Type codes, see Table 5 on page 30 . †† For new designs, this signal should be pulled high with a 10-K Ω resistor when not being utilized in the system. No change is required to existing designs that have this signal pulled low.				

Table 13. Expansion Bus Interface (Sheet 1 of 2)

Name	Power Reset or Sys Reset	Post Reset	Type†	Description
EX_CLK	Z	Z	I	Input clock signal used to sample all expansion interface inputs and clock all expansion interface outputs.
EX_ALE	Z	0	O	Address-latch enable used for multiplexed address/data bus accesses. Used in Intel and Motorola* multiplexed modes of operation.
EX_ADDR[23:0]	H	H	I/O	Expansion-bus address used as an output for data accesses over the expansion bus. Also, used as an input during reset to capture device configuration. These signals have a weak pull-up resistor attached internally. Based on the desired configuration, various address signals must be pulled low in order for the device to operate in the desired mode.
EX_WR_N	Z	1	O	Intel-mode write strobe / Motorola-mode data strobe (EXP_MOT_DS_N) / TI*-mode data strobe (TI_HDS1_N).
† For a legend of the Type codes, see Table 5 on page 30 . †† For new designs, this signal should be pulled high with a 10-K Ω resistor when not being utilized in the system. No change is required to existing designs that have this signal pulled low.				



Functional Signal Descriptions

Table 13. Expansion Bus Interface (Sheet 2 of 2)

Name	Power Reset or Sys Reset	Post Reset	Type†	Description
EX_RD_N	Z	1	O	Intel-mode read strobe / Motorola-mode read-not-write (EXPB_MOT_RNW) / TI mode read-not-write (TI_HR_W_N).
EX_CS_N[7:0]	Z	1	O	External chip selects for expansion bus. <ul style="list-style-type: none"> Chip selects 0 through 7 can be configured to support Intel or Motorola bus cycles. Chip selects 4 through 7 can be configured to support TI HPI bus cycles.
EX_DATA[15:0]	Z	0	I/O	Expansion-bus, bidirectional data
EX_IOWAIT_N	H	H	I	Data ready/acknowledge from expansion-bus devices. Expansion-bus access is halted when an external device sets EX_IOWAIT_N to logic 0 and resume from the halted location once the external device sets EX_IOWAIT_N to logic 1. This signal affects accesses that use EX_CS_N[7:0] when the chip select is configured in Intel- or Motorola-mode of operation. Should be pulled high through a 10-K Ω resistor when not being utilized in the system.
EX_RDY[3:0]	H	H	I	HPI interface ready signals. Can be configured to be active high or active low. These signals are used to halt accesses using Chip Selects 7 through 4 when the chip selects are configured to operate in HPI mode. There is one RDY signal per chip select. This signal only affects accesses that use EX_CS_N[7:4]. Should be pulled high†† through a 10-K Ω resistor when not being utilized in the system.
† For a legend of the Type codes, see Table 5 on page 30 .				
†† For new designs, this signal should be pulled high with a 10-K Ω resistor when not being utilized in the system. No change is required to existing designs that have this signal pulled low.				

Table 14. UART Interfaces (Sheet 1 of 2)

Name	Power Reset or Sys Reset	Post Reset	Type†	Description
RXDATA0	Z	VI	I	UART serial data input to High-Speed UART Pins. Should be pulled high†† through a 10-K Ω resistor when not being utilized in the system.
TXDATA0	Z	VO	O	UART serial data output. The TXD signal is set to the MARKING (logic 1) state upon a reset operation. High-Speed Serial UART Pins.
CTS0_N	H	VI/PE	I	UART CLEAR-TO-SEND input to High-Speed UART Pins. When logic 0, this pin indicates that the modem or data set connected to the UART interface of the processor is ready to exchange data. The CTS_N signal is a modem status input whose condition can be tested by the processor. Should be pulled high through a 10-K Ω resistor when not being utilized in the system.
† For a legend of the Type codes, see Table 5 on page 30 .				
†† For new designs, this signal should be pulled high with a 10-K Ω resistor when not being utilized in the system. No change is required to existing designs that have this signal pulled low.				



Functional Signal Descriptions

Table 14. UART Interfaces (Sheet 2 of 2)

Name	Power Reset or Sys Reset	Post Reset	Type†	Description
RTS0_N	H	VO/PE	O	UART REQUEST-TO-SEND output: When logic 0, this informs the modem or the data set connected to the UART interface of the processor that the UART is ready to exchange data. A reset sets the request to send signal to logic 1. LOOP-mode operation holds this signal in its inactive state (logic 1). High-Speed UART Pins.
RXDATA1	Z	VI	I	UART serial data input. Should be pulled high†† through a 10-K Ω resistor when not being utilized in the system.
TXDATA1	Z	VO	O	UART serial data output. The TXD signal is set to the MARKING (logic 1) state upon a Reset operation. Console UART Pins.
CTS1_N	H	VI/PE	I	UART CLEAR-TO-SEND input to Console UART pins. When logic 0, this pin indicates that the modem or data set connected to the UART interface of the processor is ready to exchange data. The CTS_N signal is a modem status input whose condition can be tested by the processor. Should be pulled high through a 10-K Ω resistor when not being utilized in the system.
RTS1_N	H	VO/PE	O	UART REQUEST-TO-SEND output: When logic 0, this informs the modem or the data set connected to the UART interface of the processor that the UART is ready to exchange data. A reset sets the request to send signal to logic 1. LOOP-mode operation holds this signal in its inactive state (logic 1). Console UART Pins.
† For a legend of the Type codes, see Table 5 on page 30 .				
†† For new designs, this signal should be pulled high with a 10-K Ω resistor when not being utilized in the system. No change is required to existing designs that have this signal pulled low.				

Table 15. USB Interface

Name	Power Reset or Sys Reset	Post Reset	Type†	Description
USB_DPOS	Z	Z	I/O	Positive signal of the differential USB receiver/driver.
USB_DNEG	Z	Z	I/O	Negative signal of the differential USB receiver/driver.
† For a legend of the Type codes, see Table 5 on page 30 .				



Functional Signal Descriptions

Table 16. Oscillator Interface

Name	Power Reset or Sys Reset	Post Reset	Type†	Description
OSC_IN	VI	VI	I	33.33 MHz, sinusoidal input signal. Can be driven by an oscillator.
OSC_OUT	VO	VO	O	33.33 MHz, sinusoidal output signal. Left disconnected when being driven by an oscillator.

† For a legend of the **Type** codes, see [Table 5 on page 30](#).

Table 17. GPIO Interface

Name	Power Reset or Sys Reset	Post Reset	Type†	Description
GPIO[12:0]	Z	Z	I/O	General purpose Input/Output pins. May be configured as an input or an output. As an input, each signal may be configured a processor interrupt. Default after reset is to be configured as inputs. Should be pulled high†† using a 10-K Ω resistor when not being utilized in the system.
GPIO[13]	Z	Z	I/O	General purpose input/output pins. May be configured as an input or an output. Default after reset is to be configured as inputs. Should be pulled high†† using a 10-K Ω resistor when not being utilized in the system.
GPIO[14]	Z	Z	I/O	Can be configured similar to GPIO Pin 13 or as a clock output. Configuration as an output clock can be set at various speeds of up to 33.33 MHz with various duty cycles. Configured as an input, upon reset. Should be pulled high†† though a 10-K Ω resistor when not being utilized in the system.
GPIO[15]	0	CLKOUT /VO	I/O	Can be configured similar to GPIO Pin 13 or as a clock output. Configuration as an output clock can be set at various speeds of up to 33.33 MHz with various duty cycles. Configured as an output, upon reset. Can be used to clock the expansion interface, after reset. Should be pulled high†† though a 10-K Ω resistor when not being utilized in the system.

† For a legend of the **Type** codes, see [Table 5 on page 30](#).
 †† For new designs, this signal should be pulled high with a 10-K Ω resistor when not being utilized in the system. No change is required to existing designs that have this signal pulled low.



Functional Signal Descriptions

Table 18. JTAG Interface

Name	Power Reset or Sys Reset	Post Reset	Type†	Description
JTG_TMS	H	VI/PE	I	Test mode select for the IEEE 1149.1 JTAG interface.
JTG_TDI	H	VI/PE	I	Input data for the IEEE 1149.1 JTAG interface.
JTG_TDO	Z	VO	O	Output data for the IEEE 1149.1 JTAG interface.
JTG_TRST_N	H	VI/PE	I	Used to reset the IEEE 1149.1 JTAG interface. The JTG_TRST_N signal must be asserted (driven low) during power-up, otherwise the TAP controller may not be initialized properly, and the processor may be locked. When the JTAG interface is not being used, the signal must be pulled low using a 10-K Ω resistor.
JTG_TCK	Z	VI	I	Used as the clock for the IEEE 1149.1 JTAG interface.

† For a legend of the **Type** codes, see [Table 5 on page 30](#).

Table 19. System Interface††

Name	Power Reset or Sys Reset	Post Reset	Type†	Description
BYPASS_CLK	Z	VI	I	Used for test purposes only. Must be pulled high for normal operation.
SCANTESTMODE_N	H	VI/PE	I	Used for test purposes only. Must be pulled high for normal operation.
RESET_IN_N	0	VI	I	Used as a reset input to the device when PWRON_RESET_N is in an inactive state and once power up conditions are met. Power up conditions include the following: <ul style="list-style-type: none"> — Power supplies reaching a safe stable condition and — The PLL achieving a locked state
PWRON_RESET_N	0	VI	I	Signal used at power up to reset all internal logic to a known state after the PLL has achieved a locked state. The PWRON_RESET_N input is a 1.3-V tolerant only.

† For a legend of the **Type** codes, see [Table 5 on page 30](#).

†† **IMPORTANT NOTE:** When a system-level reset is asserted to the Intel® IXP42X Product Line of Network Processors and IXC1100 Control Plane Processor — either via a power-on reset, a system reset, or a Watchdog-Timer reset — and any interface is in an active transaction (particularly the PCI bus or expansion bus, but not precluding any interface), an illegal protocol is generated. The behavior of the IXP42X product line and IXC1100 control plane processors is undefined in this situation and a reset of other attached devices may be required.



Functional Signal Descriptions

Table 19. System Interface^{††}

Name	Power Reset or Sys Reset	Post Reset	Type [†]	Description
HIGHZ_N	H	VI/PE	I	Used for test purposes only. Must be pulled high for normal operation.
PLL_LOCK	0	VO	O	Signal used to inform external reset logic that the internal PLL has achieved a locked state.
RCOMP	Tied off to a resistor	Tied off to a resistor	O	Signal used to control PCI drive strength characteristics. Drive strength is varied on PCI address, data and control signals. Pin requires a 34-Ω +/- 1% tolerance resistor to ground. Refer to Figure 13 on page 80 .
[†] For a legend of the Type codes, see Table 5 on page 30 . ^{††} IMPORTANT NOTE: When a system-level reset is asserted to the Intel [®] IXP42X Product Line of Network Processors and IXC1100 Control Plane Processor — either via a power-on reset, a system reset, or a Watchdog-Timer reset — and any interface is in an active transaction (particularly the PCI bus or expansion bus, but not precluding any interface), an illegal protocol is generated. The behavior of the IXP42X product line and IXC1100 control plane processors is undefined in this situation and a reset of other attached devices may be required.				

Table 20. Power Interface

Name	Type [†]	Description
VCC	I	1.3-V power supply input pins used for the internal logic.
VCCP	I	3.3-V power supply input pins used for the peripheral (I/O) logic.
VSS		Ground power supply input pins used for both the 3.3-V and the 1.3-V power supplies.
VCCOSCP	I	3.3-V power supply input pins used for the peripheral (I/O) logic of the analog oscillator circuitry. Require special power filtering circuitry. Refer to Figure 11 on page 79 .
VSSOSCP	I	Ground input pins used for the peripheral (I/O) logic of the analog oscillator circuitry. Used in conjunction with the VCCOSCP pins. Requires special power filtering circuitry. Refer to Figure 11 on page 79 .
VCCOSC	I	1.3-V power supply input pins used for the internal logic of the analog oscillator circuitry. Requires special power filtering circuitry. Refer to Figure 12 on page 80 .
VSSOSC	I	Ground power supply input pins used for the internal logic of the analog oscillator circuitry. Used in conjunction with the VCCOSC pins. Requires special power filtering circuitry. Refer to Figure 12 on page 80 .
VCCPLL1	I	1.3-V power supply input pins used for the internal logic of the analog phase lock-loop circuitry. Requires special power filtering circuitry. Refer to Figure 9 on page 78 .
VCCPLL2	I	1.3-V power supply input pins used for the internal logic of the analog phase lock-loop circuitry. Requires special power filtering circuitry. Refer to Figure 10 on page 79 .
[†] For a legend of the Type codes, see Table 5 on page 30 .		



4.0 Package and Pinout Information

The Intel® IXP42X Product Line of Network Processors and IXC1100 Control Plane Processor have a 492-ball, plastic ball grid array (PBGA) package for commercial-temperature applications and a pin-for-pin, compatible 492-ball, plastic ball grid array with a drop-in heat spreader (H) for extended-temperature applications.

4.1 Package Description

Figure 7. 492-Pin Lead PBGA Package

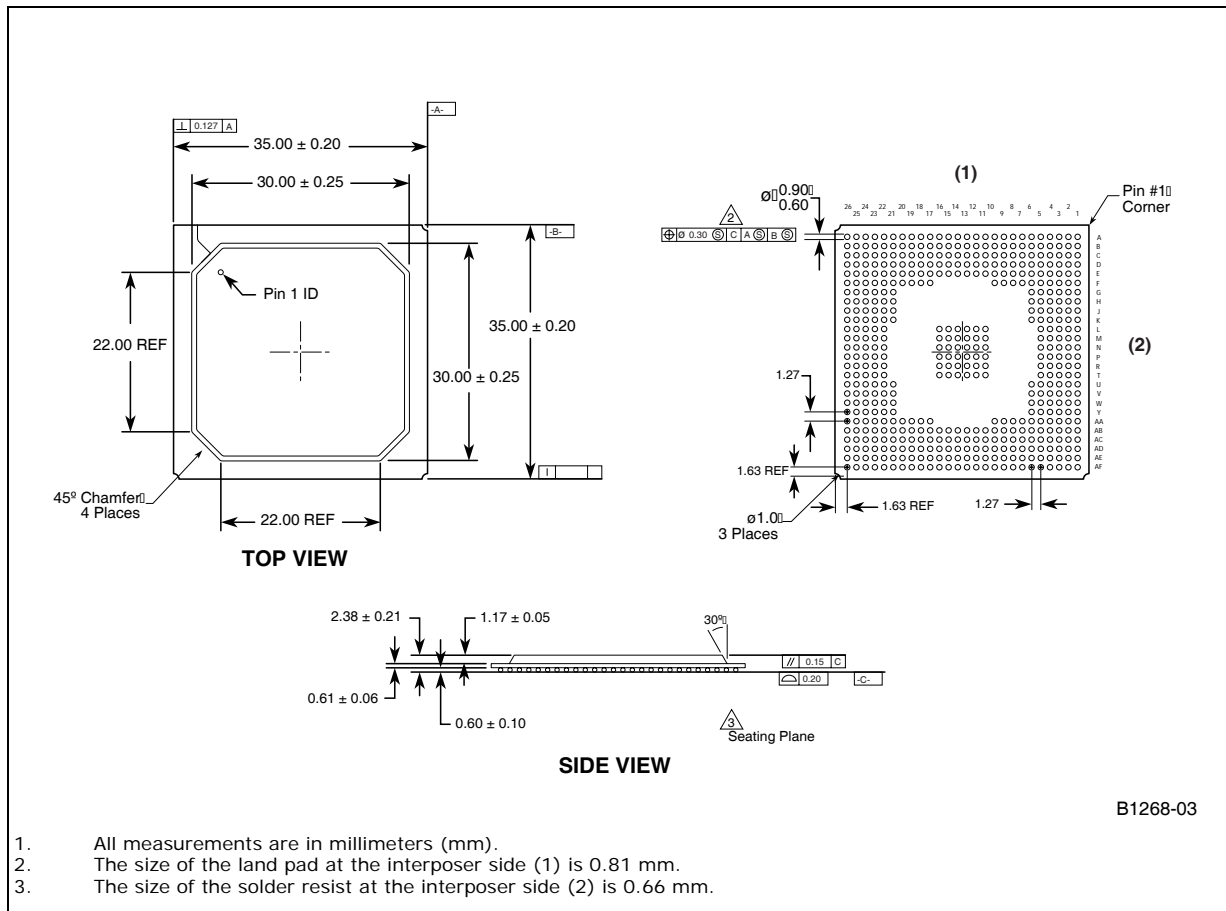

Figure 8. Package Markings

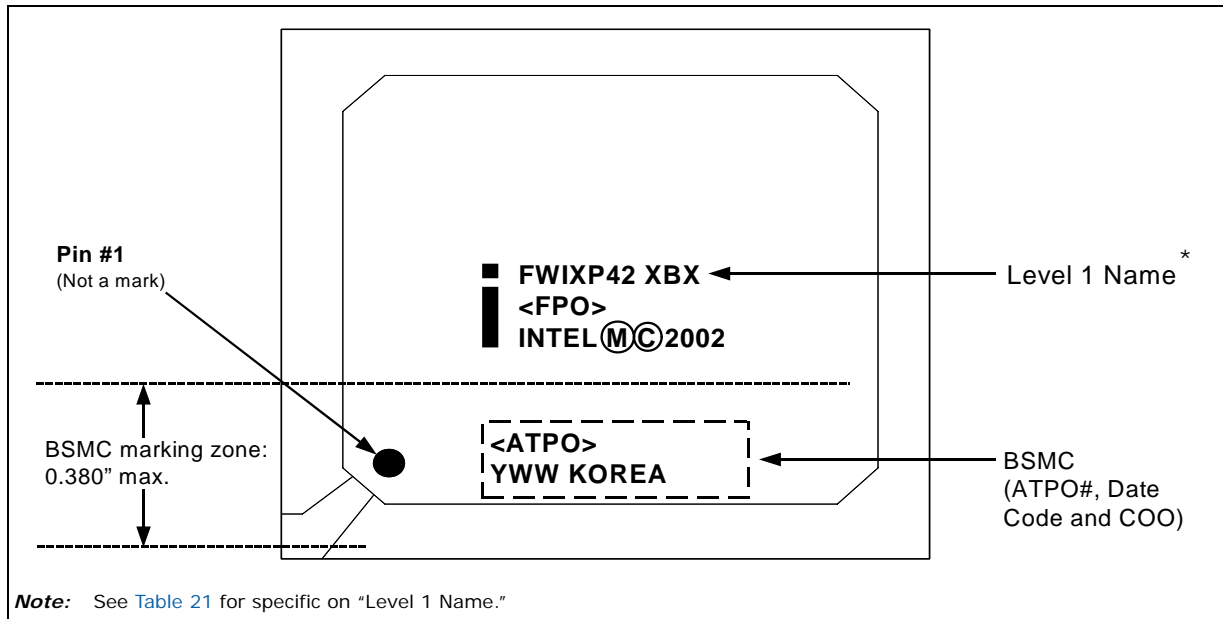

Table 21. Part Numbers for the Intel® IXP42X Product Line of Network Processors (Sheet 1 of 2)

Device	Stepping	Speed (MHz)	Extended Temp.	Lead Free	Part #
Intel® IXP425	B-1	533	Yes	Yes	EWIXP425ABDT
Intel® IXP425	B-1	266	Yes	Yes	EWIXP425ABBT
Intel® IXP425	B-1	533		Yes	PRIXP425ABD
Intel® IXP425	B-1	400		Yes	PRIXP425ABC
Intel® IXP425	B-1	266		Yes	PRIXP425ABB
Intel® IXP425	B-1	533	Yes		GWIXP425ABDT
Intel® IXP425	B-1	400	Yes		GWIXP425ABCT
Intel® IXP425	B-1	266	Yes		GWIXP425ABBT
Intel® IXP425	B-1	533			FWIXP425ABD
Intel® IXP425	B-1	400			FWIXP425ABC
Intel® IXP425	B-1	266			FWIXP425ABB
Intel® IXP423	B-1	533		Yes	PRIXP423ABD
Intel® IXP423	B-1	533			FWIXP423ABD
Intel® IXP423	B-1	266		Yes	PRIXP423ABB
Intel® IXP423	B-1	266			FWIXP423ABB
Intel® IXP422	B-1	266		Yes	PRIXP422ABB
Intel® IXP422	B-1	266			FWIXP422ABB
Intel® IXP421	B-1	266		Yes	PRIXP421ABB
Intel® IXP421	B-1	266			FWIXP421ABB
Intel® IXP420	B-1	266	Yes	Yes	EWIXP420ABBT



Table 21. Part Numbers for the Intel® IXP42X Product Line of Network Processors (Sheet 2 of 2)

Device	Stepping	Speed (MHz)	Extended Temp.	Lead Free	Part #
Intel® IXP420	B-1	266	Yes		GWIXP420ABBT
Intel® IXP420	B-1	533		Yes	PRIXP420ABD
Intel® IXP420	B-1	400		Yes	PRIXP420ABC
Intel® IXP420	B-1	266		Yes	PRIXP420ABB
Intel® IXP420	B-1	533			FWIXP420ABD
Intel® IXP420	B-1	400			FWIXP420ABC
Intel® IXP420	B-1	266			FWIXP420ABB

4.2 Signal-Pin Descriptions

In this section, separate ball-map-assignment tables are given for each model of the IXP42X product line and IXC1100 control plane processors. These tables include:

Device	Table #	Starting Page
Intel® IXP425 Network Processor	22	49
Intel® IXP423 Network Processor	22	49
Intel® IXP422 Network Processor	23	56
Intel® IXP421 Network Processor	24	63
Intel® IXP420 Network Processor and Intel® IXC1100 Control Plane Processor	25	70

Table 22. Ball Map Assignment for the Intel® IXP425 Network Processor (Sheet 1 of 7)

Ball	Signal	Ball	Signal	Ball	Signal	Ball	Signal
A1	PCI_AD[27]	B1	PCI_AD[28]	C1	PCI_AD[26]	D1	PCI_AD[25]
A2	PCI_GNT_N[1]	B2	VCCP	C2	PCI_AD[30]	D2	VSS
A3	PCI_GNT_N[3]	B3	PCI_GNT_N[2]	C3	VSS	D3	PCI_AD[31]
A4	SDM_DATA[19]	B4	VCCP	C4	PCI_INTA_N	D4	VCC
A5	SDM_DATA[27]	B5	SDM_DATA[28]	C5	VSS	D5	PCI_SERR_N
A6	SDM_DATA[26]	B6	VCCP	C6	SDM_DATA[18]	D6	VCC
A7	SDM_DATA[25]	B7	SDM_DATA[21]	C7	VSS	D7	SDM_DATA[29]
A8	SDM_DATA[23]	B8	VSS	C8	VCCP	D8	SDM_DATA[20]
A9	SDM_DATA[14]	B9	SDM_DATA[0]	C9	SDM_DATA[24]	D9	VCC
A10	SDM_DATA[13]	B10	VCCP	C10	VSS	D10	SDM_DATA[15]
A11	SDM_DATA[11]	B11	SDM_DATA[12]	C11	SDM_DATA[2]	D11	SDM_DATA[1]
A12	SDM_DATA[10]	B12	VSS	C12	SDM_DATA[4]	D12	VCC
A13	SDM_DATA[6]	B13	SDM_DATA[9]	C13	VSS	D13	SDM_DATA[5]
A14	SDM_DATA[8]	B14	VCCP	C14	SDM_DATA[7]	D14	VCC
A15	SDM_DQM[1]	B15	SDM_DQM[2]	C15	SDM_DQM[3]	D15	SDM_WE_N
A16	SDM_CS_N[0]	B16	VSS	C16	VCCP	D16	SDM_CS_N[1]
A17	SDM_CLKOUT	B17	SDM_CKE	C17	SDM_CAS_N	D17	SDM_BA[1]
A18	SDM_RAS_N	B18	VCCP	C18	SDM_ADDR[11]	D18	VCC
A19	SDM_ADDR[12]	B19	SDM_ADDR[10]	C19	VSS	D19	SDM_ADDR[0]
A20	SDM_ADDR[9]	B20	VSS	C20	SDM_ADDR[6]	D20	VSS
A21	SDM_ADDR[8]	B21	SDM_ADDR[1]	C21	SDM_ADDR[2]	D21	VCC

Note: Interfaces not being utilized at a system level require external pull-up or pull-down resistors. For specific details and requirements, see Section 3.0, "Functional Signal Descriptions" on page 30.



Table 22. Ball Map Assignment for the Intel® IXP425 Network Processor (Sheet 2 of 7)

Ball	Signal	Ball	Signal	Ball	Signal	Ball	Signal
A22	SDM_ADDR[5]	B22	VCCP	C22	VSS	D22	EX_ALE
A23	EX_RD_N	B23	EX_IOWAIT_N	C23	EX_ADDR[0]	D23	VCC
A24	EX_ADDR[1]	B24	VSS	C24	EX_ADDR[4]	D24	EX_ADDR[6]
A25	EX_ADDR[3]	B25	VCCP	C25	EX_ADDR[7]	D25	RCOMP
A26	EX_ADDR[5]	B26	EX_ADDR[9]	C26	EX_ADDR[13]	D26	EX_ADDR[17]
E1	PCI_AD[23]	F1	PCI_AD[20]	G1	PCI_AD[21]	H1	PCI_AD[16]
E2	VCCP	F2	PCI_IDSEL	G2	VCCP	H2	PCI_AD[18]
E3	PCI_REQ_N[2]	F3	VCC	G3	PCI_AD[24]	H3	VCC
E4	VSS	F4	PCI_REQ_N[0]	G4	VSS	H4	PCI_CBE_N[3]
E5	PCI_GNT_N[0]	F5	VCCP	G5	PCI_REQ_N[1]	H5	VCC
E6	SDM_DATA[16]	F6	VCC	G6	VSS	H6	PCI_REQ_N[3]
E7	VCCP	F7	SDM_DATA[31]				
E8	SDM_DATA[30]	F8	VSS				
E9	VSS	F9	SDM_DATA[17]				
E10	SDM_DATA[22]	F10	VCC				
E11	VCCP						
E12	SDM_DATA[3]						
E13	VSS						
E14	SDM_DQM[0]						
E15	VCCP						
E16	SDM_BA[0]						
E17	VSS	F17	VCC				
E18	SDM_ADDR[7]	F18	SDM_ADDR[4]				
E19	VCCP	F19	VSS				
E20	SDM_ADDR[3]	F20	USB_DPOS				
E21	USB_DNEG	F21	VCC	G21	EX_ADDR[2]	H21	VSS
E22	VCCP	F22	EX_WR_N	G22	VSS	H22	EX_ADDR[11]
E23	VSS	F23	VCC	G23	EX_ADDR[12]	H23	EX_ADDR[18]
E24	EX_ADDR[10]	F24	EX_ADDR[14]	G24	VSS	H24	VCCP
E25	EX_ADDR[15]	F25	VCCP	G25	EX_ADDR[20]	H25	VSS
E26	EX_ADDR[19]	F26	EX_ADDR[21]	G26	EX_ADDR[22]	H26	EX_CS_N[1]

Note: Interfaces not being utilized at a system level require external pull-up or pull-down resistors. For specific details and requirements, see [Section 3.0, "Functional Signal Descriptions"](#) on page 30.



Table 22. Ball Map Assignment for the Intel® IXP425 Network Processor (Sheet 3 of 7)

Ball	Signal	Ball	Signal	Ball	Signal	Ball	Signal
J1	PCI_CLKIN	K1	PCI_CBE_N[2]	L1	PCI_DEVSEL_N	M1	PCI_CBE_N[1]
J2	VCCP	K2	VSS	L2	VCCP	M2	PCI_PAR
J3	VSS	K3	PCI_AD[17]	L3	PCI_STOP_N	M3	VSS
J4	PCI_AD[22]	K4	VCCP	L4	VCC	M4	PCI_IRDY_N
J5	VSS	K5	PCI_AD[19]	L5	PCI_FRAME_N	M5	VCCP
J6	PCI_AD[29]	K6	VCC				
				L11	VSS	M11	VSS
				L12	VSS	M12	VSS
				L13	VSS	M13	VSS
				L14	VSS	M14	VSS
				L15	VSS	M15	VSS
				L16	VSS	M16	VSS
J21	EX_ADDR[8]	K21	VCC				
J22	EX_ADDR[16]	K22	VSS	L22	VCCP	M22	EX_CS_N[5]
J23	VCC	K23	EX_CS_N[0]	L23	VCC	M23	EX_CLK
J24	EX_ADDR[23]	K24	EX_CS_N[3]	L24	EX_CS_N[6]	M24	EX_DATA[2]
J25	EX_CS_N[2]	K25	VCCP	L25	EX_DATA[0]	M25	VSS
J26	EX_CS_N[4]	K26	EX_CS_N[7]	L26	EX_DATA[1]	M26	EX_DATA[3]
Note: Interfaces not being utilized at a system level require external pull-up or pull-down resistors. For specific details and requirements, see Section 3.0, "Functional Signal Descriptions" on page 30.							



Table 22. Ball Map Assignment for the Intel® IXP425 Network Processor (Sheet 4 of 7)

Ball	Signal	Ball	Signal	Ball	Signal	Ball	Signal
N1	PCI_AD[11]	P1	PCI_CBE_N[0]	R1	PCI_AD[10]	T1	PCI_AD[6]
N2	VCCP	P2	PCI_AD[14]	R2	VSS	T2	PCI_TRDY_N
N3	VCC	P3	PCI_AD[13]	R3	PCI_AD[9]	T3	VSS
N4	PCI_PERR_N	P4	VSS	R4	VCC	T4	PCI_AD[2]
N5	PCI_AD[15]	P5	PCI_AD[12]	R5	PCI_AD[4]	T5	VCCP
N11	VSS	P11	VSS	R11	VSS	T11	VSS
N12	VSS	P12	VSS	R12	VSS	T12	VSS
N13	VSS	P13	VSS	R13	VSS	T13	VSS
N14	VSS	P14	VSS	R14	VSS	T14	VSS
N15	VSS	P15	VSS	R15	VSS	T15	VSS
N16	VSS	P16	VSS	R16	VSS	T16	VSS
N22	VCC	P22	EX_DATA[6]	R22	VCCP	T22	EX_RDY_N[0]
N23	VSS	P23	EX_DATA[7]	R23	VCC	T23	VSS
N24	VCC	P24	EX_DATA[8]	R24	EX_DATA[12]	T24	EX_DATA[14]
N25	EX_DATA[4]	P25	VCCP	R25	EX_DATA[11]	T25	VSS
N26	EX_DATA[5]	P26	EX_DATA[9]	R26	EX_DATA[10]	T26	EX_DATA[13]
Note: Interfaces not being utilized at a system level require external pull-up or pull-down resistors. For specific details and requirements, see Section 3.0, "Functional Signal Descriptions" on page 30.							



Table 22. Ball Map Assignment for the Intel® IXP425 Network Processor (Sheet 5 of 7)

Ball	Signal	Ball	Signal	Ball	Signal	Ball	Signal
U1	PCI_AD[8]	V1	PCI_AD[5]	W1	PCI_AD[1]	Y1	HSS_TXCLK0
U2	VCCP	V2	VSS	W2	VCCP	Y2	HSS_RXCLK0
U3	PCI_AD[0]	V3	PCI_AD[3]	W3	HSS_RXFRAME0	Y3	HSS_TXFRAME1
U4	PCI_AD[7]	V4	VCC	W4	VSS	Y4	VCC
U5	HSS_TXDATA0	V5	HSS_TXFRAME0	W5	HSS_TXCLK1	Y5	VCCP
U6	VCC	V6	VSS	W6	HSS_RXFRAME1	Y6	ETH_TXENO
U21	VCC	V21	GPIO[6]	W21	GPIO[1]	Y21	RXDATA1
U22	GPIO[14]	V22	GPIO[9]	W22	VCCP	Y22	GPIO[0]
U23	EX_RDY_N[1]	V23	VCC	W23	GPIO[8]	Y23	VCC
U24	EX_RDY_N[2]	V24	GPIO[13]	W24	VSS	Y24	GPIO[5]
U25	GPIO[15]	V25	VCCP	W25	GPIO[11]	Y25	VCCP
U26	EX_DATA[15]	V26	EX_RDY_N[3]	W26	GPIO[12]	Y26	GPIO[10]
<p>Note: Interfaces not being utilized at a system level require external pull-up or pull-down resistors. For specific details and requirements, see Section 3.0, “Functional Signal Descriptions” on page 30.</p>							



Table 22. Ball Map Assignment for the Intel® IXP425 Network Processor (Sheet 6 of 7)

Ball	Signal	Ball	Signal	Ball	Signal	Ball	Signal
AA1	HSS_RXDATA0	AB1	HSS_TXDATA1	AC1	VSS	AD1	ETH_TXCLK0
AA2	VCCP	AB2	HSS_RXDATA1	AC2	ETH_TXDATA0[0]	AD2	ETH_RXDVO
AA3	VSS	AB3	ETH_TXDATA0[3]	AC3	VCCP	AD3	VSS
AA4	HSS_RXCLK1	AB4	ETH_TXDATA0[1]	AC4	VCC	AD4	ETH_CRSO
AA5	ETH_TXDATA0[2]	AB5	VSS	AC5	ETH_RXDATA0[0]	AD5	ETH_MDC
AA6	VCC	AB6	ETH_RXCLK0	AC6	VSS	AD6	ETH_TXDATA1[0]
AA7	ETH_RXDATA0[1]	AB7	VCCP	AC7	VCC	AD7	ETH_RXDATA1[3]
AA8	VSS	AB8	ETH_TXDATA1[2]	AC8	ETH_RXDATA1[2]	AD8	ETH_RXCLK1
AA9	ETH_TXDATA1[1]	AB9	ETH_RXDATA1[1]	AC9	VCC	AD9	VSS
AA10	VCC	AB10	VCCP	AC10	VCC	AD10	VSSOSCP
		AB11	VCCP	AC11	VCCOSCP	AD11	VCCP
		AB12	VSS	AC12	VCC	AD12	PLL_LOCK
		AB13	UTP_OP_DATA[7]	AC13	RESET_IN_N	AD13	PWRON_RESET_N
		AB14	VCCP	AC14	VCC	AD14	UTP_OP_DATA[4]
		AB15	UTP_OP_SOC	AC15	UTP_OP_DATA[1]	AD15	UTP_OP_DATA[2]
		AB16	VSS	AC16	UTP_OP_FCI	AD16	VSS
AA17	VCC	AB17	UTP_IP_DATA[6]	AC17	UTP_OP_ADDR[1]	AD17	UTP_OP_ADDR[3]
AA18	UTP_IP_FCI	AB18	VCCP	AC18	VCC	AD18	UTP_IP_DATA[7]
AA19	UTP_IP_ADDR[0]	AB19	UTP_IP_CLK	AC19	UTP_IP_DATA[2]	AD19	VCCP
AA20	VSS	AB20	UTP_IP_ADDR[1]	AC20	UTP_IP_SOC	AD20	UTP_IP_DATA[1]
AA21	VCC	AB21	SCANTESTMODE_N	AC21	VCC	AD21	UTP_IP_ADDR[4]
AA22	TXDATA1	AB22	VCCP	AC22	JTG_TRST_N	AD22	VSS
AA23	VSS	AB23	CTS0_N	AC23	VCC	AD23	JTG_TDO
AA24	GPIO[3]	AB24	CTS1_N	AC24	RXDATA0	AD24	VSS
AA25	VSS	AB25	VCCP	AC25	RTS1_N	AD25	TXDATA0
AA26	GPIO[7]	AB26	GPIO[4]	AC26	GPIO[2]	AD26	RTSO_N

Note: Interfaces not being utilized at a system level require external pull-up or pull-down resistors. For specific details and requirements, see [Section 3.0, "Functional Signal Descriptions" on page 30.](#)



Table 22. Ball Map Assignment for the Intel® IXP425 Network Processor (Sheet 7 of 7)

Ball	Signal	Ball	Signal	Ball	Signal	Ball	Signal
AE1	ETH_RXDATA0[3]	AF1	ETH_RXDATA0[2]				
AE2	VCCP	AF2	ETH_MDIO				
AE3	ETH_COLO	AF3	(Reserved)				
AE4	ETH_TXEN1	AF4	ETH_TXDATA1[3]				
AE5	VCCP	AF5	ETH_TXCLK1				
AE6	ETH_RXDV1	AF6	ETH_RXDATA1[0]				
AE7	VSS	AF7	ETH_CRS1				
AE8	ETH_COL1	AF8	VSSOSC				
AE9	VCCP	AF9	OSC_IN				
AE10	VCCPLL1	AF10	VSSOSCP				
AE11	VSS	AF11	OSC_OUT				
AE12	VCCPLL2	AF12	VCCOSC				
AE13	VCCP	AF13	BYPASS_CLK				
AE14	UTP_OP_DATA[5]	AF14	UTP_OP_DATA[6]				
AE15	VSS	AF15	UTP_OP_DATA[3]				
AE16	UTP_OP_FCO	AF16	UTP_OP_DATA[0]				
AE17	VCCP	AF17	UTP_OP_CLK				
AE18	UTP_OP_ADDR[2]	AF18	UTP_OP_ADDR[4]				
AE19	VSS	AF19	UTP_OP_ADDR[0]				
AE20	UTP_IP_DATA[4]	AF20	UTP_IP_DATA[5]				
AE21	VCCP	AF21	UTP_IP_DATA[3]				
AE22	UTP_IP_FCO	AF22	UTP_IP_DATA[0]				
AE23	VCCP	AF23	UTP_IP_ADDR[3]				
AE24	JTG_TDI	AF24	UTP_IP_ADDR[2]				
AE25	VCCP	AF25	JTG_TMS				
AE26	HIGHZ_N	AF26	JTG_TCK				
Note: Interfaces not being utilized at a system level require external pull-up or pull-down resistors. For specific details and requirements, see Section 3.0, "Functional Signal Descriptions" on page 30.							



Table 23. Ball Map Assignment for the Intel® IXP422 Network Processor (Sheet 1 of 7)

Ball	Signal	Ball	Signal	Ball	Signal	Ball	Signal
A1	PCI_AD[27]	B1	PCI_AD[28]	C1	PCI_AD[26]	D1	PCI_AD[25]
A2	PCI_GNT_N[1]	B2	VCCP	C2	PCI_AD[30]	D2	VSS
A3	PCI_GNT_N[3]	B3	PCI_GNT_N[2]	C3	VSS	D3	PCI_AD[31]
A4	SDM_DATA[19]	B4	VCCP	C4	PCI_INTA_N	D4	VCC
A5	SDM_DATA[27]	B5	SDM_DATA[28]	C5	VSS	D5	PCI_SERR_N
A6	SDM_DATA[26]	B6	VCCP	C6	SDM_DATA[18]	D6	VCC
A7	SDM_DATA[25]	B7	SDM_DATA[21]	C7	VSS	D7	SDM_DATA[29]
A8	SDM_DATA[23]	B8	VSS	C8	VCCP	D8	SDM_DATA[20]
A9	SDM_DATA[14]	B9	SDM_DATA[0]	C9	SDM_DATA[24]	D9	VCC
A10	SDM_DATA[13]	B10	VCCP	C10	VSS	D10	SDM_DATA[15]
A11	SDM_DATA[11]	B11	SDM_DATA[12]	C11	SDM_DATA[2]	D11	SDM_DATA[1]
A12	SDM_DATA[10]	B12	VSS	C12	SDM_DATA[4]	D12	VCC
A13	SDM_DATA[6]	B13	SDM_DATA[9]	C13	VSS	D13	SDM_DATA[5]
A14	SDM_DATA[8]	B14	VCCP	C14	SDM_DATA[7]	D14	VCC
A15	SDM_DQM[1]	B15	SDM_DQM[2]	C15	SDM_DQM[3]	D15	SDM_WE_N
A16	SDM_CS_N[0]	B16	VSS	C16	VCCP	D16	SDM_CS_N[1]
A17	SDM_CLKOUT	B17	SDM_CKE	C17	SDM_CAS_N	D17	SDM_BA[1]
A18	SDM_RAS_N	B18	VCCP	C18	SDM_ADDR[11]	D18	VCC
A19	SDM_ADDR[12]	B19	SDM_ADDR[10]	C19	VSS	D19	SDM_ADDR[0]
A20	SDM_ADDR[9]	B20	VSS	C20	SDM_ADDR[6]	D20	VSS
A21	SDM_ADDR[8]	B21	SDM_ADDR[1]	C21	SDM_ADDR[2]	D21	VCC
A22	SDM_ADDR[5]	B22	VCCP	C22	VSS	D22	EX_ALE
A23	EX_RD_N	B23	EX_IOWAIT_N	C23	EX_ADDR[0]	D23	VCC
A24	EX_ADDR[1]	B24	VSS	C24	EX_ADDR[4]	D24	EX_ADDR[6]
A25	EX_ADDR[3]	B25	VCCP	C25	EX_ADDR[7]	D25	RCOMP
A26	EX_ADDR[5]	B26	EX_ADDR[9]	C26	EX_ADDR[13]	D26	EX_ADDR[17]

Note: Interfaces not being utilized at a system level require external pull-up or pull-down resistors. For specific details and requirements, see Section 3.0, "Functional Signal Descriptions" on page 30.



Table 23. Ball Map Assignment for the Intel® IXP422 Network Processor (Sheet 2 of 7)

Ball	Signal	Ball	Signal	Ball	Signal	Ball	Signal
E1	PCI_AD[23]	F1	PCI_AD[20]	G1	PCI_AD[21]	H1	PCI_AD[16]
E2	VCCP	F2	PCI_IDSEL	G2	VCCP	H2	PCI_AD[18]
E3	PCI_REQ_N[2]	F3	VCC	G3	PCI_AD[24]	H3	VCC
E4	VSS	F4	PCI_REQ_N[0]	G4	VSS	H4	PCI_CBE_N[3]
E5	PCI_GNT_N[0]	F5	VCCP	G5	PCI_REQ_N[1]	H5	VCC
E6	SDM_DATA[16]	F6	VCC	G6	VSS	H6	PCI_REQ_N[3]
E7	VCCP	F7	SDM_DATA[31]				
E8	SDM_DATA[30]	F8	VSS				
E9	VSS	F9	SDM_DATA[17]				
E10	SDM_DATA[22]	F10	VCC				
E11	VCCP						
E12	SDM_DATA[3]						
E13	VSS						
E14	SDM_DQM[0]						
E15	VCCP						
E16	SDM_BA[0]						
E17	VSS	F17	VCC				
E18	SDM_ADDR[7]	F18	SDM_ADDR[4]				
E19	VCCP	F19	VSS				
E20	SDM_ADDR[3]	F20	USB_DPOS				
E21	USB_DNEG	F21	VCC	G21	EX_ADDR[2]	H21	VSS
E22	VCCP	F22	EX_WR_N	G22	VSS	H22	EX_ADDR[11]
E23	VSS	F23	VCC	G23	EX_ADDR[12]	H23	EX_ADDR[18]
E24	EX_ADDR[10]	F24	EX_ADDR[14]	G24	VSS	H24	VCCP
E25	EX_ADDR[15]	F25	VCCP	G25	EX_ADDR[20]	H25	VSS
E26	EX_ADDR[19]	F26	EX_ADDR[21]	G26	EX_ADDR[22]	H26	EX_CS_N[1]
Note: Interfaces not being utilized at a system level require external pull-up or pull-down resistors. For specific details and requirements, see Section 3.0, "Functional Signal Descriptions" on page 30.							



Table 23. Ball Map Assignment for the Intel® IXP422 Network Processor (Sheet 3 of 7)

Ball	Signal	Ball	Signal	Ball	Signal	Ball	Signal
J1	PCI_CLKIN	K1	PCI_CBE_N[2]	L1	PCI_DEVSEL_N	M1	PCI_CBE_N[1]
J2	VCCP	K2	VSS	L2	VCCP	M2	PCI_PAR
J3	VSS	K3	PCI_AD[17]	L3	PCI_STOP_N	M3	VSS
J4	PCI_AD[22]	K4	VCCP	L4	VCC	M4	PCI_IRDY_N
J5	VSS	K5	PCI_AD[19]	L5	PCI_FRAME_N	M5	VCCP
J6	PCI_AD[29]	K6	VCC				
				L11	VSS	M11	VSS
				L12	VSS	M12	VSS
				L13	VSS	M13	VSS
				L14	VSS	M14	VSS
				L15	VSS	M15	VSS
				L16	VSS	M16	VSS
J21	EX_ADDR[8]	K21	VCC				
J22	EX_ADDR[16]	K22	VSS	L22	VCCP	M22	EX_CS_N[5]
J23	VCC	K23	EX_CS_N[0]	L23	VCC	M23	EX_CLK
J24	EX_ADDR[23]	K24	EX_CS_N[3]	L24	EX_CS_N[6]	M24	EX_DATA[2]
J25	EX_CS_N[2]	K25	VCCP	L25	EX_DATA[0]	M25	VSS
J26	EX_CS_N[4]	K26	EX_CS_N[7]	L26	EX_DATA[1]	M26	EX_DATA[3]
Note: Interfaces not being utilized at a system level require external pull-up or pull-down resistors. For specific details and requirements, see Section 3.0, "Functional Signal Descriptions" on page 30.							



Table 23. Ball Map Assignment for the Intel® IXP422 Network Processor (Sheet 4 of 7)

Ball	Signal	Ball	Signal	Ball	Signal	Ball	Signal
N1	PCI_AD[11]	P1	PCI_CBE_N[0]	R1	PCI_AD[10]	T1	PCI_AD[6]
N2	VCCP	P2	PCI_AD[14]	R2	VSS	T2	PCI_TRDY_N
N3	VCC	P3	PCI_AD[13]	R3	PCI_AD[9]	T3	VSS
N4	PCI_PERR_N	P4	VSS	R4	VCC	T4	PCI_AD[2]
N5	PCI_AD[15]	P5	PCI_AD[12]	R5	PCI_AD[4]	T5	VCCP
N11	VSS	P11	VSS	R11	VSS	T11	VSS
N12	VSS	P12	VSS	R12	VSS	T12	VSS
N13	VSS	P13	VSS	R13	VSS	T13	VSS
N14	VSS	P14	VSS	R14	VSS	T14	VSS
N15	VSS	P15	VSS	R15	VSS	T15	VSS
N16	VSS	P16	VSS	R16	VSS	T16	VSS
N22	VCC	P22	EX_DATA[6]	R22	VCCP	T22	EX_RDY_N[0]
N23	VSS	P23	EX_DATA[7]	R23	VCC	T23	VSS
N24	VCC	P24	EX_DATA[8]	R24	EX_DATA[12]	T24	EX_DATA[14]
N25	EX_DATA[4]	P25	VCCP	R25	EX_DATA[11]	T25	VSS
N26	EX_DATA[5]	P26	EX_DATA[9]	R26	EX_DATA[10]	T26	EX_DATA[13]
Note: Interfaces not being utilized at a system level require external pull-up or pull-down resistors. For specific details and requirements, see Section 3.0, "Functional Signal Descriptions" on page 30.							



Table 23. Ball Map Assignment for the Intel® IXP422 Network Processor (Sheet 5 of 7)

Ball	Signal	Ball	Signal	Ball	Signal	Ball	Signal
U1	PCI_AD[8]	V1	PCI_AD[5]	W1	PCI_AD[1]	Y1	N/C
U2	VCCP	V2	VSS	W2	VCCP	Y2	N/C
U3	PCI_AD[0]	V3	PCI_AD[3]	W3	N/C	Y3	N/C
U4	PCI_AD[7]	V4	VCC	W4	VSS	Y4	VCC
U5	N/C	V5	N/C	W5	N/C	Y5	VCCP
U6	VCC	V6	VSS	W6	N/C	Y6	ETH_TXEN0
U21	VCC	V21	GPIO[6]	W21	GPIO[1]	Y21	RXDATA1
U22	GPIO[14]	V22	GPIO[9]	W22	VCCP	Y22	GPIO[0]
U23	EX_RDY_N[1]	V23	VCC	W23	GPIO[8]	Y23	VCC
U24	EX_RDY_N[2]	V24	GPIO[13]	W24	VSS	Y24	GPIO[5]
U25	GPIO[15]	V25	VCCP	W25	GPIO[11]	Y25	VCCP
U26	EX_DATA[15]	V26	EX_RDY_N[3]	W26	GPIO[12]	Y26	GPIO[10]
Note: Interfaces not being utilized at a system level require external pull-up or pull-down resistors. For specific details and requirements, see Section 3.0, "Functional Signal Descriptions" on page 30.							



Table 23. Ball Map Assignment for the Intel® IXP422 Network Processor (Sheet 6 of 7)

Ball	Signal	Ball	Signal	Ball	Signal	Ball	Signal
AA1	N/C	AB1	N/C	AC1	VSS	AD1	ETH_TXCLK0
AA2	VCCP	AB2	N/C	AC2	ETH_TXDATA0[0]	AD2	ETH_RXDVO
AA3	VSS	AB3	ETH_TXDATA0[3]	AC3	VCCP	AD3	VSS
AA4	N/C	AB4	ETH_TXDATA0[1]	AC4	VCC	AD4	ETH_CRSD
AA5	ETH_TXDATA0[2]	AB5	VSS	AC5	ETH_RXDATA0[0]	AD5	ETH_MDC
AA6	VCC	AB6	ETH_RXCLK0	AC6	VSS	AD6	ETH_TXDATA1[0]
AA7	ETH_RXDATA0[1]	AB7	VCCP	AC7	VCC	AD7	ETH_RXDATA1[3]
AA8	VSS	AB8	ETH_TXDATA1[2]	AC8	ETH_RXDATA1[2]	AD8	ETH_RXCLK1
AA9	ETH_TXDATA1[1]	AB9	ETH_RXDATA1[1]	AC9	VCC	AD9	VSS
AA10	VCC	AB10	VCCP	AC10	VCC	AD10	VSSOSCP
		AB11	VCCP	AC11	VCCOSCP	AD11	VCCP
		AB12	VSS	AC12	VCC	AD12	PLL_LOCK
		AB13	N/C	AC13	RESET_IN_N	AD13	PWRON_RESET_N
		AB14	VCCP	AC14	VCC	AD14	N/C
		AB15	N/C	AC15	N/C	AD15	N/C
		AB16	VSS	AC16	N/C	AD16	VSS
AA17	VCC	AB17	N/C	AC17	N/C	AD17	N/C
AA18	N/C	AB18	VCCP	AC18	VCC	AD18	N/C
AA19	N/C	AB19	N/C	AC19	N/C	AD19	VCCP
AA20	VSS	AB20	N/C	AC20	N/C	AD20	N/C
AA21	VCC	AB21	SCANTESTMODE_N	AC21	VCC	AD21	N/C
AA22	TXDATA1	AB22	VCCP	AC22	JTG_TRST_N	AD22	VSS
AA23	VSS	AB23	CTS0_N	AC23	VCC	AD23	JTG_TDO
AA24	GPIO[3]	AB24	CTS1_N	AC24	RXDATA0	AD24	VSS
AA25	VSS	AB25	VCCP	AC25	RTS1_N	AD25	TXDATA0
AA26	GPIO[7]	AB26	GPIO[4]	AC26	GPIO[2]	AD26	RTSO_N

Note: Interfaces not being utilized at a system level require external pull-up or pull-down resistors. For specific details and requirements, see [Section 3.0, "Functional Signal Descriptions" on page 30.](#)



Table 23. Ball Map Assignment for the Intel® IXP422 Network Processor (Sheet 7 of 7)

Ball	Signal	Ball	Signal	Ball	Signal	Ball	Signal
AE1	ETH_RXDATA0[3]	AF1	ETH_RXDATA0[2]				
AE2	VCCP	AF2	ETH_MDIO				
AE3	ETH_COLO	AF3	(Reserved)				
AE4	ETH_TXEN1	AF4	ETH_TXDATA1[3]				
AE5	VCCP	AF5	ETH_TXCLK1				
AE6	ETH_RXDV1	AF6	ETH_RXDATA1[0]				
AE7	VSS	AF7	ETH_CRS1				
AE8	ETH_COL1	AF8	VSSOSC				
AE9	VCCP	AF9	OSC_IN				
AE10	VCCPLL1	AF10	VSSOSCP				
AE11	VSS	AF11	OSC_OUT				
AE12	VCCPLL2	AF12	VCCOSC				
AE13	VCCP	AF13	BYPASS_CLK				
AE14	N/C	AF14	N/C				
AE15	VSS	AF15	N/C				
AE16	N/C	AF16	N/C				
AE17	VCCP	AF17	N/C				
AE18	N/C	AF18	N/C				
AE19	VSS	AF19	N/C				
AE20	N/C	AF20	N/C				
AE21	VCCP	AF21	N/C				
AE22	N/C	AF22	N/C				
AE23	VCCP	AF23	N/C				
AE24	JTG_TDI	AF24	N/C				
AE25	VCCP	AF25	JTG_TMS				
AE26	HIGHZ_N	AF26	JTG_TCK				

Note: Interfaces not being utilized at a system level require external pull-up or pull-down resistors. For specific details and requirements, see [Section 3.0, "Functional Signal Descriptions" on page 30.](#)



Table 24. Ball Map Assignment for the Intel® IXP421 Network Processor (Sheet 1 of 7)

Ball	Signal	Ball	Signal	Ball	Signal	Ball	Signal
A1	PCI_AD[27]	B1	PCI_AD[28]	C1	PCI_AD[26]	D1	PCI_AD[25]
A2	PCI_GNT_N[1]	B2	VCCP	C2	PCI_AD[30]	D2	VSS
A3	PCI_GNT_N[3]	B3	PCI_GNT_N[2]	C3	VSS	D3	PCI_AD[31]
A4	SDM_DATA[19]	B4	VCCP	C4	PCI_INTA_N	D4	VCC
A5	SDM_DATA[27]	B5	SDM_DATA[28]	C5	VSS	D5	PCI_SERR_N
A6	SDM_DATA[26]	B6	VCCP	C6	SDM_DATA[18]	D6	VCC
A7	SDM_DATA[25]	B7	SDM_DATA[21]	C7	VSS	D7	SDM_DATA[29]
A8	SDM_DATA[23]	B8	VSS	C8	VCCP	D8	SDM_DATA[20]
A9	SDM_DATA[14]	B9	SDM_DATA[0]	C9	SDM_DATA[24]	D9	VCC
A10	SDM_DATA[13]	B10	VCCP	C10	VSS	D10	SDM_DATA[15]
A11	SDM_DATA[11]	B11	SDM_DATA[12]	C11	SDM_DATA[2]	D11	SDM_DATA[1]
A12	SDM_DATA[10]	B12	VSS	C12	SDM_DATA[4]	D12	VCC
A13	SDM_DATA[6]	B13	SDM_DATA[9]	C13	VSS	D13	SDM_DATA[5]
A14	SDM_DATA[8]	B14	VCCP	C14	SDM_DATA[7]	D14	VCC
A15	SDM_DQM[1]	B15	SDM_DQM[2]	C15	SDM_DQM[3]	D15	SDM_WE_N
A16	SDM_CS_N[0]	B16	VSS	C16	VCCP	D16	SDM_CS_N[1]
A17	SDM_CLKOUT	B17	SDM_CKE	C17	SDM_CAS_N	D17	SDM_BA[1]
A18	SDM_RAS_N	B18	VCCP	C18	SDM_ADDR[11]	D18	VCC
A19	SDM_ADDR[12]	B19	SDM_ADDR[10]	C19	VSS	D19	SDM_ADDR[0]
A20	SDM_ADDR[9]	B20	VSS	C20	SDM_ADDR[6]	D20	VSS
A21	SDM_ADDR[8]	B21	SDM_ADDR[1]	C21	SDM_ADDR[2]	D21	VCC
A22	SDM_ADDR[5]	B22	VCCP	C22	VSS	D22	EX_ALE
A23	EX_RD_N	B23	EX_IOWAIT_N	C23	EX_ADDR[0]	D23	VCC
A24	EX_ADDR[1]	B24	VSS	C24	EX_ADDR[4]	D24	EX_ADDR[6]
A25	EX_ADDR[3]	B25	VCCP	C25	EX_ADDR[7]	D25	RCOMP
A26	EX_ADDR[5]	B26	EX_ADDR[9]	C26	EX_ADDR[13]	D26	EX_ADDR[17]

Note: Interfaces not being utilized at a system level require external pull-up or pull-down resistors. For specific details and requirements, see [Section 3.0, "Functional Signal Descriptions" on page 30.](#)



Table 24. Ball Map Assignment for the Intel® IXP421 Network Processor (Sheet 2 of 7)

Ball	Signal	Ball	Signal	Ball	Signal	Ball	Signal
E1	PCI_AD[23]	F1	PCI_AD[20]	G1	PCI_AD[21]	H1	PCI_AD[16]
E2	VCCP	F2	PCI_IDSEL	G2	VCCP	H2	PCI_AD[18]
E3	PCI_REQ_N[2]	F3	VCC	G3	PCI_AD[24]	H3	VCC
E4	VSS	F4	PCI_REQ_N[0]	G4	VSS	H4	PCI_CBE_N[3]
E5	PCI_GNT_N[0]	F5	VCCP	G5	PCI_REQ_N[1]	H5	VCC
E6	SDM_DATA[16]	F6	VCC	G6	VSS	H6	PCI_REQ_N[3]
E7	VCCP	F7	SDM_DATA[31]				
E8	SDM_DATA[30]	F8	VSS				
E9	VSS	F9	SDM_DATA[17]				
E10	SDM_DATA[22]	F10	VCC				
E11	VCCP						
E12	SDM_DATA[3]						
E13	VSS						
E14	SDM_DQM[0]						
E15	VCCP						
E16	SDM_BA[0]						
E17	VSS	F17	VCC				
E18	SDM_ADDR[7]	F18	SDM_ADDR[4]				
E19	VCCP	F19	VSS				
E20	SDM_ADDR[3]	F20	USB_DPOS				
E21	USB_DNEG	F21	VCC	G21	EX_ADDR[2]	H21	VSS
E22	VCCP	F22	EX_WR_N	G22	VSS	H22	EX_ADDR[11]
E23	VSS	F23	VCC	G23	EX_ADDR[12]	H23	EX_ADDR[18]
E24	EX_ADDR[10]	F24	EX_ADDR[14]	G24	VSS	H24	VCCP
E25	EX_ADDR[15]	F25	VCCP	G25	EX_ADDR[20]	H25	VSS
E26	EX_ADDR[19]	F26	EX_ADDR[21]	G26	EX_ADDR[22]	H26	EX_CS_N[1]

Note: Interfaces not being utilized at a system level require external pull-up or pull-down resistors. For specific details and requirements, see [Section 3.0, "Functional Signal Descriptions" on page 30.](#)



Table 24. Ball Map Assignment for the Intel® IXP421 Network Processor (Sheet 3 of 7)

Ball	Signal	Ball	Signal	Ball	Signal	Ball	Signal
J1	PCI_CLKIN	K1	PCI_CBE_N[2]	L1	PCI_DEVSEL_N	M1	PCI_CBE_N[1]
J2	VCCP	K2	VSS	L2	VCCP	M2	PCI_PAR
J3	VSS	K3	PCI_AD[17]	L3	PCI_STOP_N	M3	VSS
J4	PCI_AD[22]	K4	VCCP	L4	VCC	M4	PCI_IRDY_N
J5	VSS	K5	PCI_AD[19]	L5	PCI_FRAME_N	M5	VCCP
J6	PCI_AD[29]	K6	VCC				
				L11	VSS	M11	VSS
				L12	VSS	M12	VSS
				L13	VSS	M13	VSS
				L14	VSS	M14	VSS
				L15	VSS	M15	VSS
				L16	VSS	M16	VSS
J21	EX_ADDR[8]	K21	VCC				
J22	EX_ADDR[16]	K22	VSS	L22	VCCP	M22	EX_CS_N[5]
J23	VCC	K23	EX_CS_N[0]	L23	VCC	M23	EX_CLK
J24	EX_ADDR[23]	K24	EX_CS_N[3]	L24	EX_CS_N[6]	M24	EX_DATA[2]
J25	EX_CS_N[2]	K25	VCCP	L25	EX_DATA[0]	M25	VSS
J26	EX_CS_N[4]	K26	EX_CS_N[7]	L26	EX_DATA[1]	M26	EX_DATA[3]
Note: Interfaces not being utilized at a system level require external pull-up or pull-down resistors. For specific details and requirements, see Section 3.0, "Functional Signal Descriptions" on page 30.							



Table 24. Ball Map Assignment for the Intel® IXP421 Network Processor (Sheet 4 of 7)

Ball	Signal	Ball	Signal	Ball	Signal	Ball	Signal
N1	PCI_AD[11]	P1	PCI_CBE_N[0]	R1	PCI_AD[10]	T1	PCI_AD[6]
N2	VCCP	P2	PCI_AD[14]	R2	VSS	T2	PCI_TRDY_N
N3	VCC	P3	PCI_AD[13]	R3	PCI_AD[9]	T3	VSS
N4	PCI_PERR_N	P4	VSS	R4	VCC	T4	PCI_AD[2]
N5	PCI_AD[15]	P5	PCI_AD[12]	R5	PCI_AD[4]	T5	VCCP
N11	VSS	P11	VSS	R11	VSS	T11	VSS
N12	VSS	P12	VSS	R12	VSS	T12	VSS
N13	VSS	P13	VSS	R13	VSS	T13	VSS
N14	VSS	P14	VSS	R14	VSS	T14	VSS
N15	VSS	P15	VSS	R15	VSS	T15	VSS
N16	VSS	P16	VSS	R16	VSS	T16	VSS
N22	VCC	P22	EX_DATA[6]	R22	VCCP	T22	EX_RDY_N[0]
N23	VSS	P23	EX_DATA[7]	R23	VCC	T23	VSS
N24	VCC	P24	EX_DATA[8]	R24	EX_DATA[12]	T24	EX_DATA[14]
N25	EX_DATA[4]	P25	VCCP	R25	EX_DATA[11]	T25	VSS
N26	EX_DATA[5]	P26	EX_DATA[9]	R26	EX_DATA[10]	T26	EX_DATA[13]
Note: Interfaces not being utilized at a system level require external pull-up or pull-down resistors. For specific details and requirements, see Section 3.0, "Functional Signal Descriptions" on page 30.							



Table 24. Ball Map Assignment for the Intel® IXP421 Network Processor (Sheet 5 of 7)

Ball	Signal	Ball	Signal	Ball	Signal	Ball	Signal
U1	PCI_AD[8]	V1	PCI_AD[5]	W1	PCI_AD[1]	Y1	HSS_TXCLK0
U2	VCCP	V2	VSS	W2	VCCP	Y2	HSS_RXCLK0
U3	PCI_AD[0]	V3	PCI_AD[3]	W3	HSS_RXFRAME0	Y3	HSS_TXFRAME1
U4	PCI_AD[7]	V4	VCC	W4	VSS	Y4	VCC
U5	HSS_TXDATA0	V5	HSS_TXFRAME0	W5	HSS_TXCLK1	Y5	VCCP
U6	VCC	V6	VSS	W6	HSS_RXFRAME1	Y6	ETH_TXENO
U21	VCC	V21	GPIO[6]	W21	GPIO[1]	Y21	RXDATA1
U22	GPIO[14]	V22	GPIO[9]	W22	VCCP	Y22	GPIO[0]
U23	EX_RDY_N[1]	V23	VCC	W23	GPIO[8]	Y23	VCC
U24	EX_RDY_N[2]	V24	GPIO[13]	W24	VSS	Y24	GPIO[5]
U25	GPIO[15]	V25	VCCP	W25	GPIO[11]	Y25	VCCP
U26	EX_DATA[15]	V26	EX_RDY_N[3]	W26	GPIO[12]	Y26	GPIO[10]
Note: Interfaces not being utilized at a system level require external pull-up or pull-down resistors. For specific details and requirements, see Section 3.0, "Functional Signal Descriptions" on page 30 .							



Table 24. Ball Map Assignment for the Intel® IXP421 Network Processor (Sheet 6 of 7)

Ball	Signal	Ball	Signal	Ball	Signal	Ball	Signal
AA1	HSS_RXDATA0	AB1	HSS_TXDATA1	AC1	VSS	AD1	ETH_TXCLK0
AA2	VCCP	AB2	HSS_RXDATA1	AC2	ETH_TXDATA0[0]	AD2	ETH_RXDVO
AA3	VSS	AB3	ETH_TXDATA0[3]	AC3	VCCP	AD3	VSS
AA4	HSS_RXCLK1	AB4	ETH_TXDATA0[1]	AC4	VCC	AD4	ETH_CRSO
AA5	ETH_TXDATA0[2]	AB5	VSS	AC5	ETH_RXDATA0[0]	AD5	ETH_MDC
AA6	VCC	AB6	ETH_RXCLK0	AC6	VSS	AD6	N/C
AA7	ETH_RXDATA0[1]	AB7	VCCP	AC7	VCC	AD7	N/C
AA8	VSS	AB8	N/C	AC8	N/C	AD8	N/C
AA9	N/C	AB9	N/C	AC9	VCC	AD9	VSS
AA10	VCC	AB10	VCCP	AC10	VCC	AD10	VSSOSCP
		AB11	VCCP	AC11	VCCOSCP	AD11	VCCP
		AB12	VSS	AC12	VCC	AD12	PLL_LOCK
		AB13	UTP_OP_DATA[7]	AC13	RESET_IN_N	AD13	PWRON_RESET_N
		AB14	VCCP	AC14	VCC	AD14	UTP_OP_DATA[4]
		AB15	UTP_OP_SOC	AC15	UTP_OP_DATA[1]	AD15	UTP_OP_DATA[2]
		AB16	VSS	AC16	UTP_OP_FCI	AD16	VSS
AA17	VCC	AB17	UTP_IP_DATA[6]	AC17	UTP_OP_ADDR[1]	AD17	UTP_OP_ADDR[3]
AA18	UTP_IP_FCI	AB18	VCCP	AC18	VCC	AD18	UTP_IP_DATA[7]
AA19	UTP_IP_ADDR[0]	AB19	UTP_IP_CLK	AC19	UTP_IP_DATA[2]	AD19	VCCP
AA20	VSS	AB20	UTP_IP_ADDR[1]	AC20	UTP_IP_SOC	AD20	UTP_IP_DATA[1]
AA21	VCC	AB21	SCANTESTMODE_N	AC21	VCC	AD21	UTP_IP_ADDR[4]
AA22	TXDATA1	AB22	VCCP	AC22	JTG_TRST_N	AD22	VSS
AA23	VSS	AB23	CTS0_N	AC23	VCC	AD23	JTG_TDO
AA24	GPIO[3]	AB24	CTS1_N	AC24	RXDATA0	AD24	VSS
AA25	VSS	AB25	VCCP	AC25	RTS1_N	AD25	TXDATA0
AA26	GPIO[7]	AB26	GPIO[4]	AC26	GPIO[2]	AD26	RTS0_N

Note: Interfaces not being utilized at a system level require external pull-up or pull-down resistors. For specific details and requirements, see [Section 3.0, "Functional Signal Descriptions" on page 30.](#)



Table 24. Ball Map Assignment for the Intel® IXP421 Network Processor (Sheet 7 of 7)

Ball	Signal	Ball	Signal	Ball	Signal	Ball	Signal
AE1	ETH_RXDATA0[3]	AF1	ETH_RXDATA0[2]				
AE2	VCCP	AF2	ETH_MDIO				
AE3	ETH_COLO	AF3	(Reserved)				
AE4	N/C	AF4	N/C				
AE5	VCCP	AF5	N/C				
AE6	N/C	AF6	N/C				
AE7	VSS	AF7	N/C				
AE8	N/C	AF8	VSSOSC				
AE9	VCCP	AF9	OSC_IN				
AE10	VCCPLL1	AF10	VSSOSCP				
AE11	VSS	AF11	OSC_OUT				
AE12	VCCPLL2	AF12	VCCOSC				
AE13	VCCP	AF13	BYPASS_CLK				
AE14	UTP_OP_DATA[5]	AF14	UTP_OP_DATA[6]				
AE15	VSS	AF15	UTP_OP_DATA[3]				
AE16	UTP_OP_FCO	AF16	UTP_OP_DATA[0]				
AE17	VCCP	AF17	UTP_OP_CLK				
AE18	UTP_OP_ADDR[2]	AF18	UTP_OP_ADDR[4]				
AE19	VSS	AF19	UTP_OP_ADDR[0]				
AE20	UTP_IP_DATA[4]	AF20	UTP_IP_DATA[5]				
AE21	VCCP	AF21	UTP_IP_DATA[3]				
AE22	UTP_IP_FCO	AF22	UTP_IP_DATA[0]				
AE23	VCCP	AF23	UTP_IP_ADDR[3]				
AE24	JTG_TDI	AF24	UTP_IP_ADDR[2]				
AE25	VCCP	AF25	JTG_TMS				
AE26	HIGHZ_N	AF26	JTG_TCK				
Note: Interfaces not being utilized at a system level require external pull-up or pull-down resistors. For specific details and requirements, see Section 3.0, "Functional Signal Descriptions" on page 30.							



Table 25. Ball Map Assignment for the Intel® IXP420 Network Processor and Intel® IXC1100 Control Plane Processor (Sheet 1 of 7)

Ball	Signal	Ball	Signal	Ball	Signal	Ball	Signal
A1	PCI_AD[27]	B1	PCI_AD[28]	C1	PCI_AD[26]	D1	PCI_AD[25]
A2	PCI_GNT_N[1]	B2	VCCP	C2	PCI_AD[30]	D2	VSS
A3	PCI_GNT_N[3]	B3	PCI_GNT_N[2]	C3	VSS	D3	PCI_AD[31]
A4	SDM_DATA[19]	B4	VCCP	C4	PCI_INTA_N	D4	VCC
A5	SDM_DATA[27]	B5	SDM_DATA[28]	C5	VSS	D5	PCI_SERR_N
A6	SDM_DATA[26]	B6	VCCP	C6	SDM_DATA[18]	D6	VCC
A7	SDM_DATA[25]	B7	SDM_DATA[21]	C7	VSS	D7	SDM_DATA[29]
A8	SDM_DATA[23]	B8	VSS	C8	VCCP	D8	SDM_DATA[20]
A9	SDM_DATA[14]	B9	SDM_DATA[0]	C9	SDM_DATA[24]	D9	VCC
A10	SDM_DATA[13]	B10	VCCP	C10	VSS	D10	SDM_DATA[15]
A11	SDM_DATA[11]	B11	SDM_DATA[12]	C11	SDM_DATA[2]	D11	SDM_DATA[1]
A12	SDM_DATA[10]	B12	VSS	C12	SDM_DATA[4]	D12	VCC
A13	SDM_DATA[6]	B13	SDM_DATA[9]	C13	VSS	D13	SDM_DATA[5]
A14	SDM_DATA[8]	B14	VCCP	C14	SDM_DATA[7]	D14	VCC
A15	SDM_DQM[1]	B15	SDM_DQM[2]	C15	SDM_DQM[3]	D15	SDM_WE_N
A16	SDM_CS_N[0]	B16	VSS	C16	VCCP	D16	SDM_CS_N[1]
A17	SDM_CLKOUT	B17	SDM_CKE	C17	SDM_CAS_N	D17	SDM_BA[1]
A18	SDM_RAS_N	B18	VCCP	C18	SDM_ADDR[11]	D18	VCC
A19	SDM_ADDR[12]	B19	SDM_ADDR[10]	C19	VSS	D19	SDM_ADDR[0]
A20	SDM_ADDR[9]	B20	VSS	C20	SDM_ADDR[6]	D20	VSS
A21	SDM_ADDR[8]	B21	SDM_ADDR[1]	C21	SDM_ADDR[2]	D21	VCC
A22	SDM_ADDR[5]	B22	VCCP	C22	VSS	D22	EX_ALE
A23	EX_RD_N	B23	EX_IOWAIT_N	C23	EX_ADDR[0]	D23	VCC
A24	EX_ADDR[1]	B24	VSS	C24	EX_ADDR[4]	D24	EX_ADDR[6]
A25	EX_ADDR[3]	B25	VCCP	C25	EX_ADDR[7]	D25	RCOMP
A26	EX_ADDR[5]	B26	EX_ADDR[9]	C26	EX_ADDR[13]	D26	EX_ADDR[17]

Note: Interfaces not being utilized at a system level require external pull-up or pull-down resistors. For specific details and requirements, see Section 3.0, "Functional Signal Descriptions" on page 30.



Table 25. Ball Map Assignment for the Intel® IXP420 Network Processor and Intel® IXC1100 Control Plane Processor (Sheet 2 of 7)

Ball	Signal	Ball	Signal	Ball	Signal	Ball	Signal
E1	PCI_AD[23]	F1	PCI_AD[20]	G1	PCI_AD[21]	H1	PCI_AD[16]
E2	VCCP	F2	PCI_IDSEL	G2	VCCP	H2	PCI_AD[18]
E3	PCI_REQ_N[2]	F3	VCC	G3	PCI_AD[24]	H3	VCC
E4	VSS	F4	PCI_REQ_N[0]	G4	VSS	H4	PCI_CBE_N[3]
E5	PCI_GNT_N[0]	F5	VCCP	G5	PCI_REQ_N[1]	H5	VCC
E6	SDM_DATA[16]	F6	VCC	G6	VSS	H6	PCI_REQ_N[3]
E7	VCCP	F7	SDM_DATA[31]				
E8	SDM_DATA[30]	F8	VSS				
E9	VSS	F9	SDM_DATA[17]				
E10	SDM_DATA[22]	F10	VCC				
E11	VCCP						
E12	SDM_DATA[3]						
E13	VSS						
E14	SDM_DQM[0]						
E15	VCCP						
E16	SDM_BA[0]						
E17	VSS	F17	VCC				
E18	SDM_ADDR[7]	F18	SDM_ADDR[4]				
E19	VCCP	F19	VSS				
E20	SDM_ADDR[3]	F20	USB_DPOS				
E21	USB_DNEG	F21	VCC	G21	EX_ADDR[2]	H21	VSS
E22	VCCP	F22	EX_WR_N	G22	VSS	H22	EX_ADDR[11]
E23	VSS	F23	VCC	G23	EX_ADDR[12]	H23	EX_ADDR[18]
E24	EX_ADDR[10]	F24	EX_ADDR[14]	G24	VSS	H24	VCCP
E25	EX_ADDR[15]	F25	VCCP	G25	EX_ADDR[20]	H25	VSS
E26	EX_ADDR[19]	F26	EX_ADDR[21]	G26	EX_ADDR[22]	H26	EX_CS_N[1]
Note: Interfaces not being utilized at a system level require external pull-up or pull-down resistors. For specific details and requirements, see Section 3.0, "Functional Signal Descriptions" on page 30.							



Table 25. Ball Map Assignment for the Intel® IXP420 Network Processor and Intel® IXC1100 Control Plane Processor (Sheet 3 of 7)

Ball	Signal	Ball	Signal	Ball	Signal	Ball	Signal
J1	PCI_CLKIN	K1	PCI_CBE_N[2]	L1	PCI_DEVSEL_N	M1	PCI_CBE_N[1]
J2	VCCP	K2	VSS	L2	VCCP	M2	PCI_PAR
J3	VSS	K3	PCI_AD[17]	L3	PCI_STOP_N	M3	VSS
J4	PCI_AD[22]	K4	VCCP	L4	VCC	M4	PCI_IRDY_N
J5	VSS	K5	PCI_AD[19]	L5	PCI_FRAME_N	M5	VCCP
J6	PCI_AD[29]	K6	VCC				
				L11	VSS	M11	VSS
				L12	VSS	M12	VSS
				L13	VSS	M13	VSS
				L14	VSS	M14	VSS
				L15	VSS	M15	VSS
				L16	VSS	M16	VSS
J21	EX_ADDR[8]	K21	VCC				
J22	EX_ADDR[16]	K22	VSS	L22	VCCP	M22	EX_CS_N[5]
J23	VCC	K23	EX_CS_N[0]	L23	VCC	M23	EX_CLK
J24	EX_ADDR[23]	K24	EX_CS_N[3]	L24	EX_CS_N[6]	M24	EX_DATA[2]
J25	EX_CS_N[2]	K25	VCCP	L25	EX_DATA[0]	M25	VSS
J26	EX_CS_N[4]	K26	EX_CS_N[7]	L26	EX_DATA[1]	M26	EX_DATA[3]
Note: Interfaces not being utilized at a system level require external pull-up or pull-down resistors. For specific details and requirements, see Section 3.0, "Functional Signal Descriptions" on page 30.							



Table 25. Ball Map Assignment for the Intel® IXP420 Network Processor and Intel® IXC1100 Control Plane Processor (Sheet 4 of 7)

Ball	Signal	Ball	Signal	Ball	Signal	Ball	Signal
N1	PCI_AD[11]	P1	PCI_CBE_N[0]	R1	PCI_AD[10]	T1	PCI_AD[6]
N2	VCCP	P2	PCI_AD[14]	R2	VSS	T2	PCI_TRDY_N
N3	VCC	P3	PCI_AD[13]	R3	PCI_AD[9]	T3	VSS
N4	PCI_PERR_N	P4	VSS	R4	VCC	T4	PCI_AD[2]
N5	PCI_AD[15]	P5	PCI_AD[12]	R5	PCI_AD[4]	T5	VCCP
N11	VSS	P11	VSS	R11	VSS	T11	VSS
N12	VSS	P12	VSS	R12	VSS	T12	VSS
N13	VSS	P13	VSS	R13	VSS	T13	VSS
N14	VSS	P14	VSS	R14	VSS	T14	VSS
N15	VSS	P15	VSS	R15	VSS	T15	VSS
N16	VSS	P16	VSS	R16	VSS	T16	VSS
N22	VCC	P22	EX_DATA[6]	R22	VCCP	T22	EX_RDY_N[0]
N23	VSS	P23	EX_DATA[7]	R23	VCC	T23	VSS
N24	VCC	P24	EX_DATA[8]	R24	EX_DATA[12]	T24	EX_DATA[14]
N25	EX_DATA[4]	P25	VCCP	R25	EX_DATA[11]	T25	VSS
N26	EX_DATA[5]	P26	EX_DATA[9]	R26	EX_DATA[10]	T26	EX_DATA[13]
Note: Interfaces not being utilized at a system level require external pull-up or pull-down resistors. For specific details and requirements, see Section 3.0, "Functional Signal Descriptions" on page 30.							



Table 25. Ball Map Assignment for the Intel® IXP420 Network Processor and Intel® IXC1100 Control Plane Processor (Sheet 6 of 7)

Ball	Signal	Ball	Signal	Ball	Signal	Ball	Signal
AA1	N/C	AB1	N/C	AC1	VSS	AD1	ETH_TXCLK0
AA2	VCCP	AB2	N/C	AC2	ETH_TXDATA0[0]	AD2	ETH_RXDV0
AA3	VSS	AB3	ETH_TXDATA0[3]	AC3	VCCP	AD3	VSS
AA4	N/C	AB4	ETH_TXDATA0[1]	AC4	VCC	AD4	ETH_CR_S0
AA5	ETH_TXDATA0[2]	AB5	VSS	AC5	ETH_RXDATA0[0]	AD5	ETH_MDC
AA6	VCC	AB6	ETH_RXCLK0	AC6	VSS	AD6	ETH_TXDATA1[0]
AA7	ETH_RXDATA0[1]	AB7	VCCP	AC7	VCC	AD7	ETH_RXDATA1[3]
AA8	VSS	AB8	ETH_TXDATA1[2]	AC8	ETH_RXDATA1[2]	AD8	ETH_RXCLK1
AA9	ETH_TXDATA1[1]	AB9	ETH_RXDATA1[1]	AC9	VCC	AD9	VSS
AA10	VCC	AB10	VCCP	AC10	VCC	AD10	VSSOSCP
		AB11	VCCP	AC11	VCCOSCP	AD11	VCCP
		AB12	VSS	AC12	VCC	AD12	PLL_LOCK
		AB13	N/C	AC13	RESET_IN_N	AD13	PWRON_RESET_N
		AB14	VCCP	AC14	VCC	AD14	N/C
		AB15	N/C	AC15	N/C	AD15	N/C
		AB16	VSS	AC16	N/C	AD16	VSS
AA17	VCC	AB17	N/C	AC17	N/C	AD17	N/C
AA18	N/C	AB18	VCCP	AC18	VCC	AD18	N/C
AA19	N/C	AB19	N/C	AC19	N/C	AD19	VCCP
AA20	VSS	AB20	N/C	AC20	N/C	AD20	N/C
AA21	VCC	AB21	SCANTESTMODE_N	AC21	VCC	AD21	N/C
AA22	TXDATA1	AB22	VCCP	AC22	JTG_TRST_N	AD22	VSS
AA23	VSS	AB23	CTS0_N	AC23	VCC	AD23	JTG_TDO
AA24	GPIO[3]	AB24	CTS1_N	AC24	RXDATA0	AD24	VSS
AA25	VSS	AB25	VCCP	AC25	RTS1_N	AD25	TXDATA0
AA26	GPIO[7]	AB26	GPIO[4]	AC26	GPIO[2]	AD26	RTS0_N
Note: Interfaces not being utilized at a system level require external pull-up or pull-down resistors. For specific details and requirements, see Section 3.0, "Functional Signal Descriptions" on page 30.							



Table 25. Ball Map Assignment for the Intel® IXP420 Network Processor and Intel® IXC1100 Control Plane Processor (Sheet 7 of 7)

Ball	Signal	Ball	Signal	Ball	Signal	Ball	Signal
AE1	ETH_RXDATA0[3]	AF1	ETH_RXDATA0[2]				
AE2	VCCP	AF2	ETH_MDIO				
AE3	ETH_COLO	AF3	(Reserved)				
AE4	ETH_TXEN1	AF4	ETH_TXDATA1[3]				
AE5	VCCP	AF5	ETH_TXCLK1				
AE6	ETH_RXDV1	AF6	ETH_RXDATA1[0]				
AE7	VSS	AF7	ETH CRS1				
AE8	ETH_COL1	AF8	VSSOSC				
AE9	VCCP	AF9	OSC_IN				
AE10	VCCPLL1	AF10	VSSOSCP				
AE11	VSS	AF11	OSC_OUT				
AE12	VCCPLL2	AF12	VCCOSC				
AE13	VCCP	AF13	BYPASS_CLK				
AE14	N/C	AF14	N/C				
AE15	VSS	AF15	N/C				
AE16	N/C	AF16	N/C				
AE17	VCCP	AF17	N/C				
AE18	N/C	AF18	N/C				
AE19	VSS	AF19	N/C				
AE20	N/C	AF20	N/C				
AE21	VCCP	AF21	N/C				
AE22	N/C	AF22	N/C				
AE23	VCCP	AF23	N/C				
AE24	JTG_TDI	AF24	N/C				
AE25	VCCP	AF25	JTG_TMS				
AE26	HIGHZ_N	AF26	JTG_TCK				

Note: Interfaces not being utilized at a system level require external pull-up or pull-down resistors. For specific details and requirements, see Section 3.0, "Functional Signal Descriptions" on page 30.

4.3 Package Thermal Specifications

The thermal characterization parameter “ΨJT” is proportional to the temperature difference between the top, center of the package and the junction temperature.

This can be a useful value for verifying device temperatures in an actual environment. By measuring the package of the device, the junction temperature can be estimated, if the thermal characterization parameter has been measured under similar conditions.

The use of ΨJT should not be confused with Θjc, which is the thermal resistance from the device junction to the external surface of the package or case nearest the die attachment — as the case is held at a constant temperature.

<p>Case temperature = Junction Temperature - (ΨJT * Power Dissipation)</p> <p>$T_{JC} = T_J - (\Psi_{JT} * \text{Power Dissipation})$</p>
--

The case temperature can then be monitored to make sure that the maximum junction temperature is not violated. Examples are given in the following sections.



4.3.1 Commercial Temperature

“Commercial” temperature range is defined in terms of the ambient temperature range, which is specified as 0° C to 70° C. The maximum power (P) is 2.4 W and the maximum junction temperature (Tj) is 115° C.

Ψ_{JT} for commercial temperature is 0.89° C/W.

Using the preceding junction-temperature formula, the commercial temperature for a 266 MHz device — assuming a maximum power of 2 W — would be:

$T_{JC} = 115^{\circ}\text{C} - (0.89 * 2.0)$ $T_{JC} = 113.22^{\circ}\text{C}$

4.3.2 Extended Temperature

“Extended” temperature range is defined in terms of the ambient temperature range, which is specified as -40° C to 85° C. The maximum power (P) is 2.4 W and the maximum junction temperature (Tj) is 115° C.

Ψ_{JT} for extended temperature is 0.32° C/W.

Using the preceding junction-temperature formula, the extended temperature for a 533 MHz device — assuming a maximum power of 2.4 W — would be:

$T_{JC} = 115^{\circ}\text{C} - (0.32 * 2.4)$ $T_{JC} = 114.23^{\circ}\text{C}$

5.0 Electrical Specifications

5.1 Absolute Maximum Ratings

Parameter	Maximum Rating
Ambient Air Temperature (Extended)	-40° C to 85° C
Ambient Air Temperature (Commercial)	0° C to 70° C
Supply Voltage (Intel XScale® processor)	-0.3 V to 2.1V
Supply Voltage I/O	-0.3 V to 3.6V
Supply Voltage Oscillator (V _{CCOSC})	-0.3 V to 2.1V
Supply Voltage Oscillator (V _{CCOSCP})	-0.3 V to 3.6V
Supply Voltage PLL (V _{CCPLL1})	-0.3 V to 2.1V
Supply Voltage PLL (V _{CCPLL2})	-0.3 V to 2.1V
Voltage On Any I/O Ball	-0.3 V to 3.6V
Storage Temperature	-55° C to 125° C

Warning: Stressing the device beyond the “absolute maximum ratings” may cause permanent damage. These are stress ratings only. Operation beyond the “operating conditions” is not recommended and extended exposure beyond the “operating conditions” may affect device reliability.

5.2 V_{CCPLL1} , V_{CCPLL2} , V_{CCOSCP} , V_{CCOSC} Pin Requirements

To reduce voltage-supply noise on the analog sections of the Intel® IXP42X Product Line of Network Processors and IXC1100 Control Plane Processor, the phase-lock loop circuits (V_{CCPLL1} , V_{CCPLL2}) and oscillator circuit (V_{CCOSCP} , V_{CCOSC}) require isolated voltage supplies.

The filter circuits for each supply are shown in the following sections.

5.2.1 V_{CCPLL1} Requirement

A parallel combination of a 10-nF capacitor — for bypass — and a 200-nF capacitor — for a first-order filter with a cut-off frequency below 30 MHz — must be connected to the V_{CCPLL1} pin of the Intel® IXP42X product line and IXC1100 control plane processors.

The ground of both capacitors should be connected to the nearest V_{SS} supply pin. Both capacitors should be located less than 0.5 inch away from the V_{CCPLL1} pin and the associated V_{SS} pin. In order to achieve the 200-nF capacitance, a parallel combination of two 100-nF capacitors may be used as long as the capacitors are placed directly beside each other.

Figure 9. V_{CCPLL1} Power Filtering Diagram

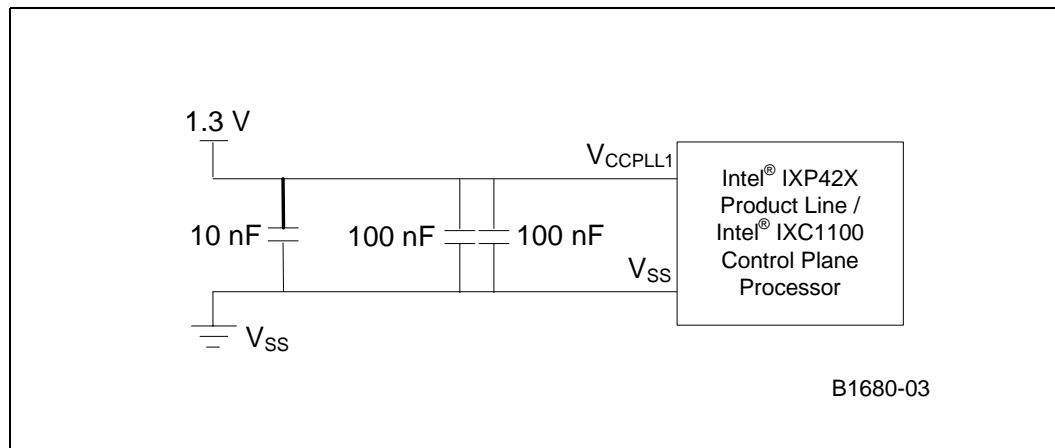

5.2.2 V_{CCPLL2} Requirement

A parallel combination of a 10-nF capacitor — for bypass — and a 200-nF capacitor — for a first-order filter with a cut-off frequency below 30 MHz — must be connected to the V_{CCPLL2} pin of the IXP42X product line and IXC1100 control plane processors.

The ground of both capacitors should be connected to the nearest V_{SS} supply pin. Both capacitors should be located less than 0.5 inch away from the V_{CCPLL2} pin and the associated V_{SS} pin. In order to achieve the 200-nF capacitance, a parallel combination of two 100-nF capacitors may be used as long as the capacitors are placed directly beside each other.



Figure 10. V_{CCPLL2} Power Filtering Diagram

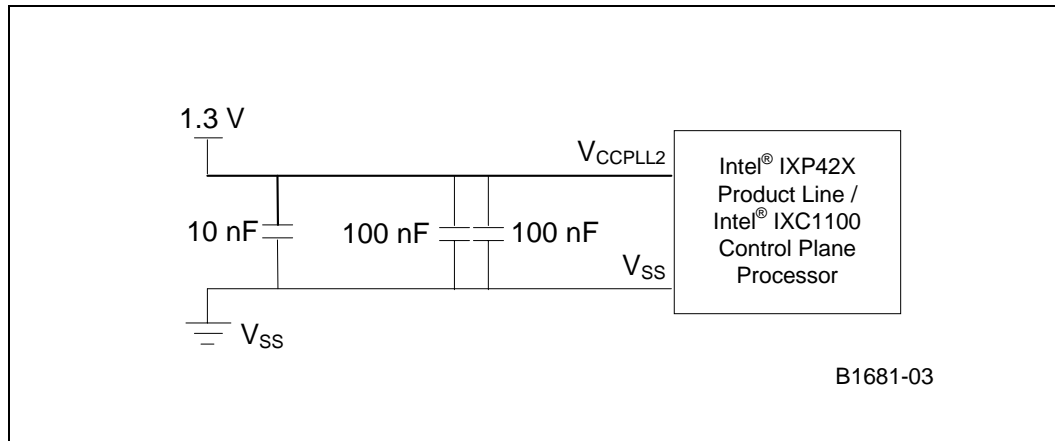

5.2.3 V_{CCOSCP} Requirement

A single 170-nF capacitor must be connected between the V_{CCP_OSC} pin and V_{SSP_OSC} pin of the IXP42X product line and IXC1100 control plane processors. This capacitor value provides both bypass and filtering.

When 170 nF is an inconvenient size, capacitor values between 150 nF to 200 nF could be used with little adverse effects, assuming that the effective series resistance of the 200-nF capacitor is under 50 m Ω .

In order to achieve a 200-nF capacitance, a parallel combination of two 100-nF capacitors may be used as long as the capacitors are placed directly beside each other. V_{SSP_OSC} consists of two pins, AD10 and AF10. Ensure that both pins are connected as shown in Figure 11.

Figure 11. V_{CCOSCP} Power Filtering Diagram

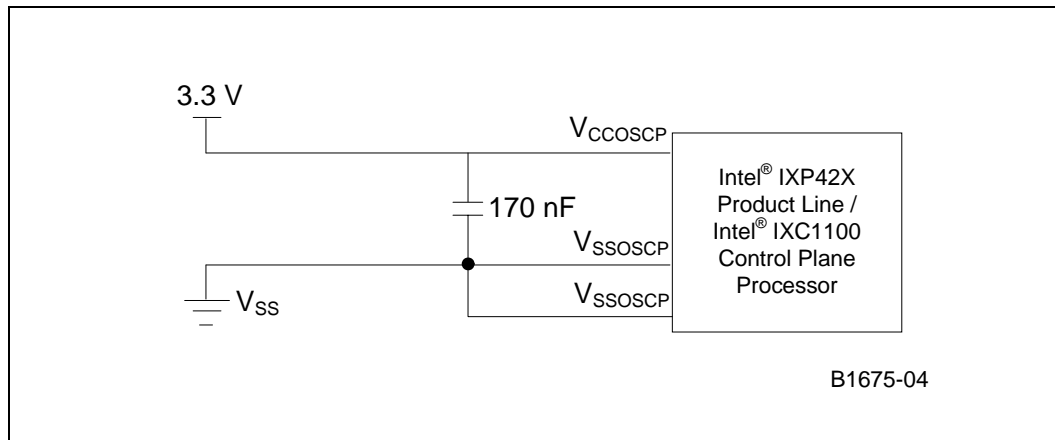

5.2.4 V_{CCOSC} Requirement

A parallel combination of a 10-nF capacitor — for bypass — and a 200-nF capacitor — for a first-order filter with a cut-off frequency below 33 MHz — must be connected to both of the V_{CCOSC} pins of the IXP42X product line and IXC1100 control plane processors.

The grounds of both capacitors should be connected to the V_{SSOSC} supply pin. Both capacitors should be located less than 0.5 inch away from the V_{CCOSC} pin and the associated V_{SSOSC} pin.

In order to achieve a 200-nF capacitance, a parallel combination of two 100-nF capacitors may be used as long as the capacitors are placed directly beside each other.

Figure 12. V_{CCOSC} Power Filtering Diagram

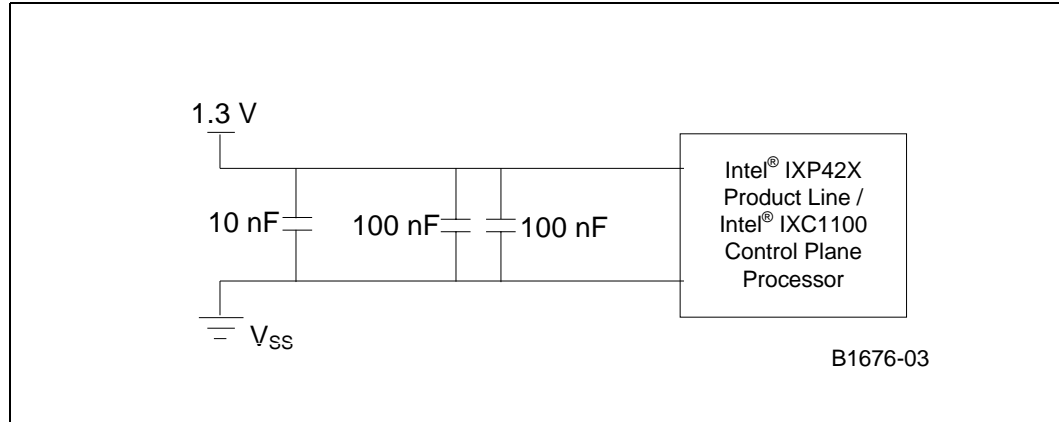

5.3 RCOMP Pin Requirements

Figure 13 shows the requirements for the RCOMP pin.

Figure 13. RCOMP Pin External Resistor Requirements

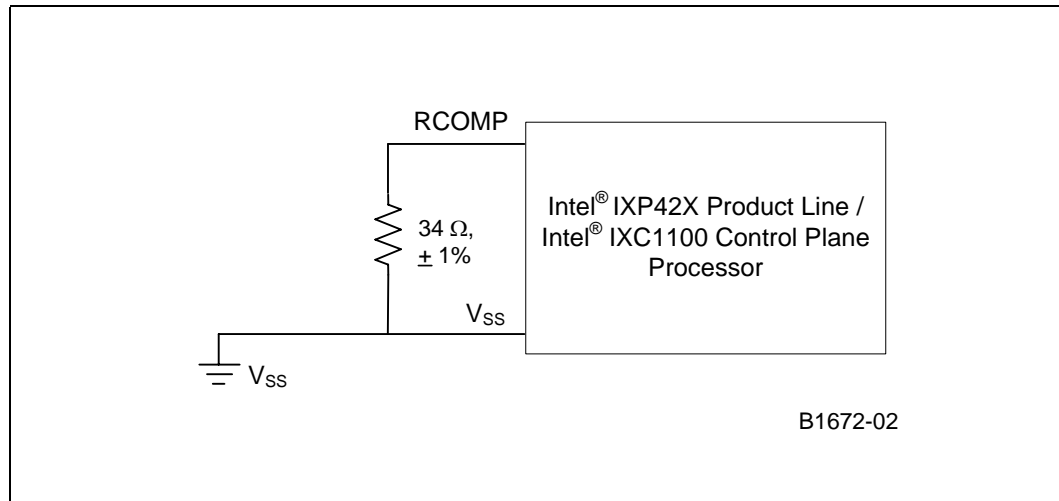



5.4 DC Specifications

5.4.1 Operating Conditions

Table 26. Operating Conditions

Symbol	Parameter	Min.	Typ.	Max.	Units	Notes
V _{CCP}	Voltage supplied to the I/O.	3.135	3.3	3.465	V	
V _{CC}	Voltage supplied to the internal logic.	1.235	1.3	1.365	V	
V _{CCOSC}	Voltage supplied to the internal oscillator logic.	1.235	1.3	1.365	V	
V _{CCOSCP}	Voltage supplied to the oscillator I/O.	3.135	3.3	3.465	V	
V _{CCPLL1}	Voltage supplied to the analog phase-lock loop.	1.235	1.3	1.365	V	
V _{CCPLL2}	Voltage supplied to the analog phase-lock loop.	1.235	1.3	1.365	V	

5.4.2 PCI DC Parameters

Table 27. PCI DC Parameters

Symbol	Parameter	Conditions	Min.	Typ.	Max.	Units	Notes
V _{IH}	Input-high voltage		0.5 V _{CCP}			V	4
V _{IL}	Input-low voltage				0.3 V _{CCP}	V	3
V _{OH}	Output-high voltage	I _{OUT} = -500 μA	0.9 V _{CCP}			V	3
V _{OL}	Output-low voltage	I _{OUT} = 1500 μA			0.1 V _{CCP}	V	3
I _{IL}	Input-leakage current	0 < V _{IN} < V _{CCP}	-10		10	μA	1, 3
C _{IN}	Input-pin capacitance			5		pF	2, 3
C _{OUT}	I/O or output pin capacitance			5		pF	2, 3
C _{IDSEL}	IDSEL-pin capacitance			5		pF	2, 3
L _{PIN}	Pin inductance			20		nH	2, 3

Notes:

- Input leakage currents include hi-Z output leakage for all bidirectional buffers with tri-state outputs.
- These values are typical values seen by the manufacturing process and are not tested.
- For additional information, see the *PCI Local Bus Specification, Rev. 2.2*.
- Refer to the product specification update.

5.4.3 USB DC Parameters

Table 28. USB v1.1 DC Parameters

Symbol	Parameter	Conditions	Min.	Typ.	Max.	Units	Notes
V _{IH}	Input-high voltage		2.0			V	1
V _{IL}	Input-low voltage				0.8	V	
V _{OH}	Output-high voltage	I _{OUT} = -6.1 * V _{OH} mA	2.8			V	
V _{OL}	Output-low voltage	I _{OUT} = 6.1 * V _{OH} mA			0.3	V	
I _{IL}	Input-leakage current	0 < V _{IN} < V _{CCP}	-10		10	μA	
C _{IN}	Input-pin capacitance			5		pF	2

Notes:

- Refer to the product specification update.
- These values are typical values seen by the manufacturing process and are not tested



5.4.4 UTOPIA Level 2 DC Parameters

Table 29. UTOPIA Level 2 DC Parameters

Symbol	Parameter	Conditions	Min.	Typ.	Max.	Units	Notes
V _{IH}	Input-high voltage		2.0			V	
V _{IL}	Input-low voltage				0.8	V	
V _{OH}	Output-high voltage	I _{OUT} = -8 mA	2.4			V	
V _{OL}	Output-low voltage	I _{OUT} = 8 mA			0.5	V	
I _{OH}	Output current at high voltage	V _{OH} > 2.4 V	-8			mA	
I _{OL}	Output current at low voltage	V _{OL} < 0.5 V	8			mA	
I _{IL}	Input-leakage current	0 < V _{IN} < V _{CCP}	-10		10	μA	1
C _{IN}	Input-pin capacitance			5		pF	2
C _{OUT}	I/O or output pin capacitance			5		pF	2

Notes:
 1. Input leakage currents include hi-Z output leakage for all bidirectional buffers with tri-state outputs.
 2. These values are typical values seen by the manufacturing process and are not tested.

5.4.5 MII DC Parameters

Table 30. MII DC Parameters

Symbol	Parameter	Conditions	Min.	Typ.	Max.	Units	Notes
V _{IH}	Input-high voltage		2.0			V	
V _{IL}	Input-low voltage				0.8	V	
V _{OH}	Output-high voltage	I _{OUT} = -4 mA	2.4			V	
V _{OL}	Output-low voltage	I _{OUT} = 4mA			0.4	V	
I _{OH}	Output current at high voltage	V _{OH} > 2.4 V	-8			mA	
I _{OL}	Output current at low voltage	V _{OL} < 0.4 V	8			mA	
I _{IL}	Input-leakage current	0 < V _{IN} < V _{CCP}	-10		10	μA	
C _{IN}	Input-pin capacitance			5		pF	1

Note:
 1. These values are typical values seen by the manufacturing process and are not tested.

5.4.6 MDIO DC Parameters

Table 31. MDIO DC Parameters (Sheet 1 of 2)

Symbol	Parameter	Conditions	Min.	Typ.	Max.	Units	Notes
V _{IH}	Input-high voltage		2.0			V	
V _{IL}	Input-low voltage				0.8	V	
V _{OH}	Output-high voltage	I _{OUT} = -4 mA	2.4			V	
V _{OL}	Output-low voltage	I _{OUT} = 4 mA			0.4	V	

Note:
 1. These values are typical values seen by the manufacturing process and are not tested.



Table 31. MDIO DC Parameters (Sheet 2 of 2)

Symbol	Parameter	Conditions	Min.	Typ.	Max.	Units	Notes
I _{IL}	Input-leakage current	0 < V _{IN} < V _{CCP}	-10		10	μA	
C _{IN}	Input-pin capacitance			5		pF	1
C _{INMDIO}	Input-pin capacitance			5		pF	1
Note:							
1. These values are typical values seen by the manufacturing process and are not tested.							

5.4.7 SDRAM Bus DC Parameters

Table 32. SDRAM Bus DC Parameters

Symbol	Parameter	Conditions	Min.	Typ.	Max.	Units	Notes
V _{IH}	Input-high voltage		2.0			V	1
V _{IL}	Input-low voltage				0.8	V	2
V _{OH}	Output-high voltage	I _{OUT} = -4 mA	2.4			V	
V _{OL}	Output-low voltage	I _{OUT} = 4 mA			0.4	V	
I _{IL}	Input-leakage current	0 < V _{IN} < V _{CCP}	-5		5	μA	
I _{OL}	Output-leakage current	0 < V _{IN} < V _{CCP}	-5		5	μA	
C _{INCLK}	Input-pin capacitance			4		pF	3
C _{IO}	I/O-pin capacitance			5		pF	3
Notes:							
1. V _{IH} overshoot: V _{IH (MAX)} = V _{CCP} + 2 V for a pulse width ≤ 3 ns, and the pulse width cannot be greater than one third of the cycle rate.							
2. V _{IL} undershoot: V _{IL (MIN)} = -2 V for a pulse width ≤ 3 ns cannot be exceeded.							
3. These values are typical values seen by the manufacturing process and are not tested.							

5.4.8 Expansion Bus DC Parameters

Table 33. Expansion Bus DC Parameters

Symbol	Parameter	Conditions	Min.	Typ.	Max.	Units	Notes
V _{IH}	Input-high voltage		2.0			V	
V _{IL}	Input-low voltage				0.8	V	
V _{OH}	Output-high voltage	I _{OUT} = -4 mA	2.4			V	1
V _{OL}	Output-low voltage	I _{OUT} = 4 mA			0.4	V	1
I _{IL}	Input-leakage current	0 < V _{IN} < V _{CCP}	-10		10	μA	
C _{IN}	Input-pin capacitance			5		pF	2
Notes:							
1. Test conditions were a 70 pF load to ground.							
2. These values are typical values seen by the manufacturing process and are not tested.							



5.4.9 High-Speed, Serial Interface 0 DC Parameters

Table 34. High-Speed, Serial Interface 0 DC Parameters

Symbol	Parameter	Conditions	Min.	Typ.	Max.	Units	Notes
V_{IH}	Input-high voltage		2.0			V	
V_{IL}	Input-low voltage				0.8	V	
V_{OH}	Output-high voltage	$I_{OUT} = -8$ mA	2.4			V	
V_{OL}	Output-low voltage	$I_{OUT} = 8$ mA			0.4	V	
I_{IL}	Input-leakage current	$0 < V_{IN} < V_{CCP}$	-10		10	μ A	
C_{IN}	Input-pin capacitance			5		pF	1
Note: 1. These values are typical values seen by the manufacturing process and are not tested.							

5.4.10 High-Speed, Serial Interface 1 DC Parameters

Table 35. High-Speed, Serial Interface 1 DC Parameters

Symbol	Parameter	Conditions	Min.	Typ.	Max.	Units	Notes
V_{IH}	Input-high voltage		2.0			V	
V_{IL}	Input-low voltage				0.8	V	
V_{OH}	Output-high voltage	$I_{OUT} = -8$ mA	2.4			V	
V_{OL}	Output-low voltage	$I_{OUT} = 8$ mA			0.4	V	
I_{IL}	Input-leakage current	$0 < V_{IN} < V_{CCP}$	-10		10	μ A	
C_{IN}	Input-pin capacitance			5		pF	1
Note: 1. These values are typical values seen by the manufacturing process and are not tested.							

5.4.11 High-Speed and Console UART DC Parameters

Table 36. UART DC Parameters

Symbol	Parameter	Conditions	Min.	Typ.	Max.	Units	Notes
V_{IH}	Input-high voltage		2.0			V	
V_{IL}	Input-low voltage				0.8	V	
V_{OH}	Output-high voltage	$I_{OUT} = -4$ mA	2.4			V	
V_{OL}	Output-low voltage	$I_{OUT} = 4$ mA			0.4	V	
I_{IL}	Input-leakage current	$0 < V_{IN} < V_{CCP}$	-10		10	μ A	
C_{IN}	Input-pin capacitance			5		pF	1
Note: 1. These values are typical values seen by the manufacturing process and are not tested.							



5.4.12 GPIO DC Parameters

Table 37. GPIO DC Parameters

Symbol	Parameter	Conditions	Min.	Typ.	Max.	Units	Notes
V _{IH}	Input-high voltage		2.0			V	
V _{IL}	Input-low voltage				0.8	V	
V _{OH}	Output-high voltage for GPIO 0 to GPIO 13	I _{OUT} = -16 mA	2.4			V	
V _{OL}	Output-low voltage for GPIO 0 to GPIO 13	I _{OUT} = 16 mA			0.4	V	
V _{OH}	Output-high voltage for GPIO 14 and GPIO 15	I _{OUT} = -4 mA	2.4			V	
V _{OL}	Output-low voltage for GPIO 14 and GPIO 15	I _{OUT} = 4 mA			0.4	V	
I _{IL}	Input-leakage current	0 < V _{IN} < V _{CCP}	-10		10	μA	
C _{IN}	Input-pin capacitance			5		pF	

5.4.13 JTAG AND PLL_LOCK DC Parameters

Table 38. JTAG AND PLL_LOCK DC Parameters @ 3.3V

Symbol	Parameter	Conditions	Min.	Typ.	Max.	Units	Notes
V _{IH}	Input-high voltage		2.0			V	
V _{IL}	Input-low voltage				0.8	V	
V _{OH}	Output-high voltage	I _{OUT} = -4 mA	2.4			V	
V _{OL}	Output-low voltage	I _{OUT} = 4 mA			0.4	V	
I _{IL}	Input-leakage current	0 < V _{IN} < V _{CCP}	-10		10	μA	
C _{IN}	Input-pin capacitance			5		pF	1
Note:							
1. These values are typical values seen by the manufacturing process and are not tested.							

5.4.14 Reset DC Parameters

Table 39. PWRON_RESET_N DC Parameters

Symbol	Parameter	Conditions	Min.	Typ.	Max.	Units	Notes
V _{IH}	Input-high voltage		1.0		1.3	V	The input voltage must not exceed 1.3V or long-term reliability may be adversely affected.
V _{IL}	Input-low voltage				0.3	V	
I _{IL}	Input leakage current	0 < V _{IN} < 1.3V	-500		10	μA	
C _{IN}	Input Capacitance				1	pF	Simulated results.



Table 40. RESET_IN_N Parameters @ 3.3V

Symbol	Parameter	Conditions	Min.	Typ.	Max.	Units	Notes
V _{IH}	Input-high voltage		2.0			V	
V _{IL}	Input-low voltage				0.8	V	

5.5 AC Specifications

5.5.1 Clock Signal Timings

5.5.1.1 Processor Clock Timings

Table 41. Devices' Clock Timings (Oscillator Reference)

Symbol	Parameter	Min.	Nom.	Max.	Units	Notes
V _{IH}	Input-high voltage	2.0			V	
V _{IL}	Input-low voltage			0.8	V	
T _{FREQUENCY}	Clock frequency for IXP42X product line and IXC1100 control plane processors oscillator.		33.33		MHz	1, 3
Δ _{FREQUENCY}	Clock tolerance over -40° C to 85° C.	-50		50	ppm	
C _{IN}	Pin capacitance of IXP42X product line and IXC1100 control plane processors' inputs.		5		pF	
T _{DC}	Duty cycle	35	50	65	%	2
Notes: 1. This value is an oscillator input. Use as an oscillator input, tie to the crystal input pin and leave the crystal output pin disconnected. 2. This parameter applies when driving the clock input with an oscillator. 3. Where the IXP42X product line or IXC1100 control plane processor is configured with an input reference-clock, the slew rate should never be faster than 2.5 V/nS to ensure proper PLL operation. To help ensure proper PLL operation at the slower slew rate, the VIH and VIL voltage levels need to be within the specified range at an input clock frequency of 33.33 MHz.						

Table 42. Processors' Clock Timings Spread Spectrum Parameters

Spread-Spectrum Conditions	Min	Max	Notes
Frequency deviation from 33.33 MHz as a percentage	-2.0%	+0.0%	Characterized and guaranteed by design, but not tested. Do not over-clock the PLL input. The A.C. timings will not be guaranteed if the device exceeds 33.33 MHz.
Modulation Frequency		50 KHz	Characterized and guaranteed by design, but not tested
Notes: 1. It is important to note that when using spread spectrum clocking, other clocks in the system will change frequency over a specific range. This change in other clocks can present some system level limitations. Refer to the application note titled <i>Spread Spectrum Clocking to Reduce EMI Application Note</i> , when designing a product that utilizes spread spectrum clocking.			



Figure 14. Typical Connection to an Oscillator

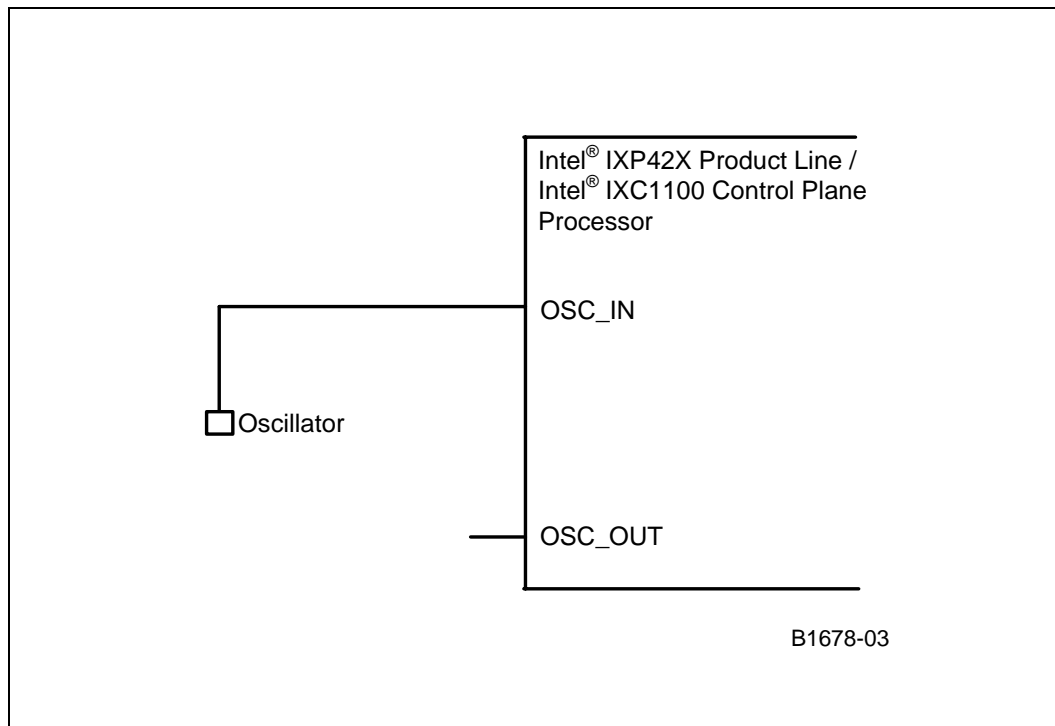

5.5.1.2 PCI Clock Timings

Table 43. PCI Clock Timings

Symbol	Parameter	33 MHz		66 MHz		Units	Notes
		Min.	Max.	Min.	Max.		
T _{PERIODPCICK}	Clock period for PCI Clock	30		15		ns	
T _{CLKHIGH}	PCI Clock high time	11		6		ns	
T _{CLKLOW}	PCI Clock low time	11		6		ns	
T _{SLEW RATE}	Slew Rate requirements for PCI Clock	1	4	1.5	4	V/ns	

5.5.1.3 MII Clock Timings

Table 44. MII Clock Timings

Symbol	Parameter	Min.	Nom.	Max.	Units	Notes
T _{period100Mbit}	Clock period for Tx and Rx Ethernet clocks		40	40	ns	
T _{period10Mbit}	Clock period for Tx and Rx Ethernet clocks		400	400	ns	
T _{duty}	Duty cycle for Tx and Rx Ethernet clocks	35	50	65	%	
Frequency Tolerance	Frequency tolerance requirement for Tx and Rx Ethernet clocks		+/- 50	+/- 100	ppm	

5.5.1.4 UTOPIA Level 2 Clock Timings

Table 45. UTOPIA Level 2 Clock Timings

Symbol	Parameter	Min.	Nom.	Max.	Units	Notes
T_{period}	Clock period for Tx and Rx UTOPIA Level 2 clocks			30.303	ns	1
T_{duty}	Duty cycle for Tx and Rx UTOPIA Level 2 clocks	40	50	60	%	1
$T_{\text{rise/fall}}$	Rise and fall time requirements for Tx and Rx UTOPIA Level 2 clocks			2	ns	1
Note: 1. The UTOPIA interface can operate at a minimum frequency greater than 0 Hz.						

5.5.1.5 Expansion Bus Clock Timings

Table 46. Expansion Bus Clock Timings

Symbol	Parameter	Min.	Nom.	Max.	Units	Notes
T_{period}	Clock period for expansion-bus clock	15.15		333.33	ns	
T_{duty}	Duty cycle for expansion-bus clock	40	50	60	%	
$T_{\text{rise/fall}}$	Rise and fall time requirements for expansion-bus clock			2	ns	

5.5.2 Bus Signal Timings

The AC timing waveforms are shown in the following sections.

5.5.2.1 PCI

Figure 15. PCI Output Timing

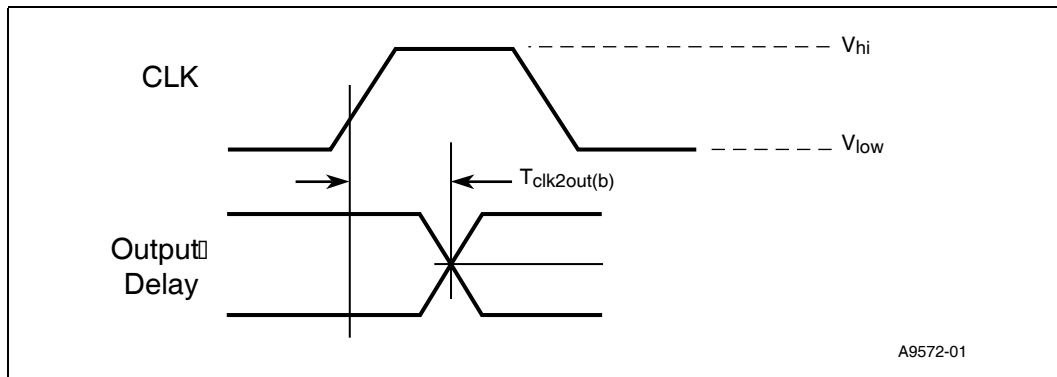

Note: $V_{HI} = 0.6 V_{CC}$ and $V_{LOW} = 0.2 V_{CC}$



Figure 16. PCI Input Timing

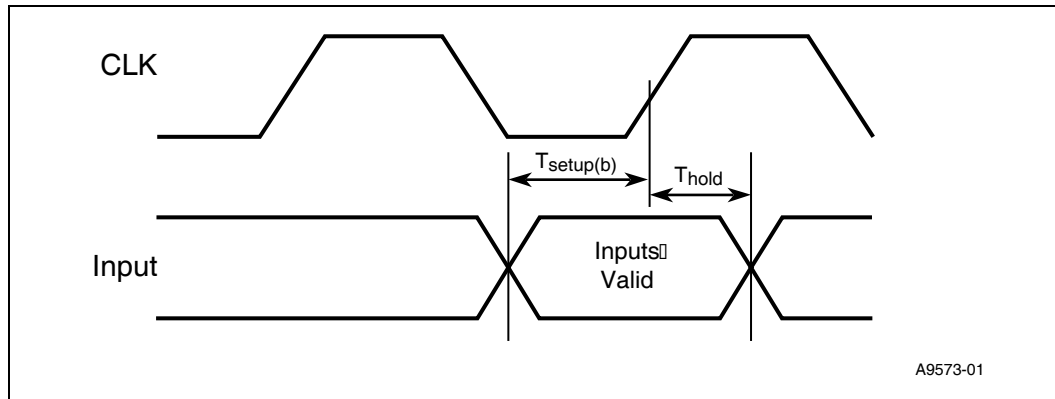

A9573-01

Table 47. PCI Bus Signal Timings

Symbol	Parameter	33 MHz		66 MHz		Units	Notes
		Min.	Max.	Min.	Max.		
$T_{clk2outb}$	Clock to output for all bused signals. This is the PCI_AD[31:0], PCI_CBE_N [3:0], PCI_PAR, PCI_FRAME_N, PCI_IRDY_N, PCI_TRDY_N, PCI_STOP_N, PCI_DEVSEL_N, PCI_PERR_N, PCI_SERR_N	2	11	1	6	ns	1, 2, 5, 7, 8
$T_{clk2out}$	Clock to output for all point-to-point signals. This is the PCI_GNT_N and PCI_REQ_N(0) only.	2	12	1	6	ns	1, 2, 5, 7, 8
T_{setupb}	Input setup time for all bused signals. This is the PCI_AD[31:0], PCI_CBE_N [3:0], PCI_PAR, PCI_FRAME_N, PCI_IRDY_N, PCI_TRDY_N, PCI_STOP_N, PCI_DEVSEL_N, PCI_PERR_N, PCI_SERR_N	7		3		ns	4, 6, 7, 8
T_{setup}	Input setup time for all point-to-point signals. This is the PCI_REQ_N and PCI_GNT_N(0) only.	10, 12		5		ns	4, 7, 8
T_{hold}	Input hold time from clock.	0		0		ns	4, 7, 8
$T_{rst-off}$	Reset active-to-output float delay		40		40	ns	5, 6, 7, 8

Notes:

- See the timing measurement conditions.
- Parts compliant to the 3.3 V signaling environment.
- REQ# and GNT# are point-to-point signals and have different output valid delay and input setup times than do bused signals. GNT# has a setup of 10 ns for 33 MHz and 5 ns for 66 MHz; REQ# has a setup of 12 ns for 33 MHz and 5 ns for 66 MHz.
- RST# is asserted and de-asserted asynchronously with respect to CLK.
- All PCI outputs must be asynchronously driven to a tri-state value when RST# is active.
- Setup time applies only when the device is not driving the pin. Devices cannot drive and receive signals at the same time.
- Timing was tested with a 70-pF capacitor to ground.
- For additional information, see the *PCI Local Bus Specification, Rev. 2.2*.

5.5.2.2 USB Interface

For timing parameters, see the USB 1.1 specification. The IXP42X product line and IXC1100 control plane processors' USB 1.1 interface is a device or function controller only. The IXP42X product line and IXC1100 control plane processors' USB v 1.1 interface cannot be line-powered.

5.5.2.3 UTOPIA Level 2 (33 MHz)

Figure 17. UTOPIA Level 2 Input Timings

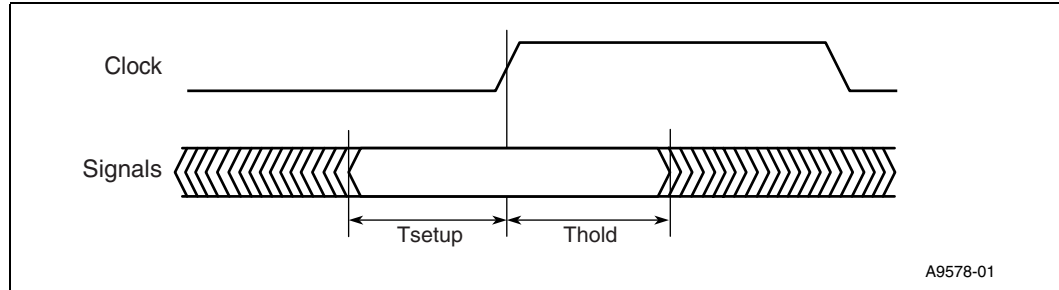

A9578-01

Table 48. UTOPIA Level 2 Input Timings Values

Symbol	Parameter	Min.	Max.	Units	Notes
T_{setup}	Input setup prior to rising edge of clock. Inputs included in this timing are UTP_IP_DATA[7:0], UTP_IP_SOC, AND UTP_IP_FCI, and UTP_OP_FCI.	8		ns	
T_{hold}	Input hold time after the rising edge of the clock. Inputs included in this timing are UTP_IP_DATA[7:0], UTP_IP_SOC, and UTP_IP_FCI, and UTP_OP_FCI.	1		ns	

Figure 18. UTOPIA Level 2 Output Timings

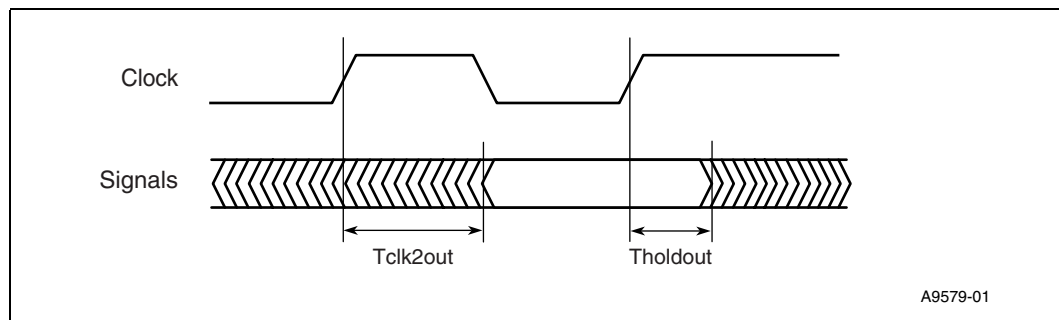

A9579-01



Table 49. UTOPIA Level 2 Output Timings Values

Symbol	Parameter	Min.	Max.	Units	Notes
$T_{clk2out}$	Rising edge of clock to signal output. Outputs included in this timing are UTP_IP_DATA[3:0], UTP_OP_SOC, UTP_OP_FCO, UTP_IP_FCO, UTP_OP_DATA[7:0], and UTP_OP_ADDR[3:0].		17	ns	1
$T_{holdout}$	Signal output hold time after the rising edge of the clock. Outputs included in this timing are UTP_IP_DATA[3:0], UTP_OP_SOC, UTP_OP_FCO, UTP_IP_FCO, UTP_OP_DATA[7:0], and UTP_OP_ADDR[3:0].	1		ns	1
Note: 1. Timing was tested with a 70-pF capacitor to ground.					

5.5.2.4 MII

Figure 19. MII Output Timings

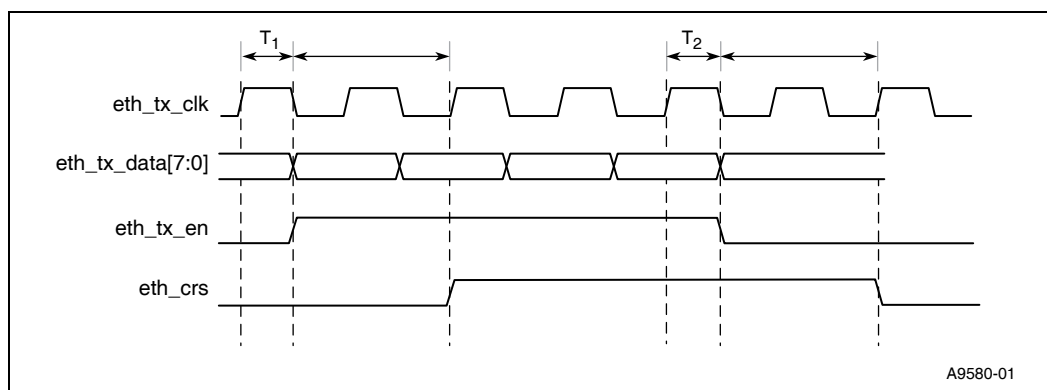

Table 50. MII Output Timings Values

Symbol	Parameter	Min.	Max.	Units	Notes
T_1	Clock to output delay for ETH_TXDATA and ETH_TXEN.		17	ns	1
T_2	ETH_TXDATA and ETH_TXEN hold time after ETH_TXCLK.	2		ns	
Note: 1. These values satisfy the MII specification requirement of 0 ns to 25 ns clock to output delay.					

Figure 20. MII Input Timings

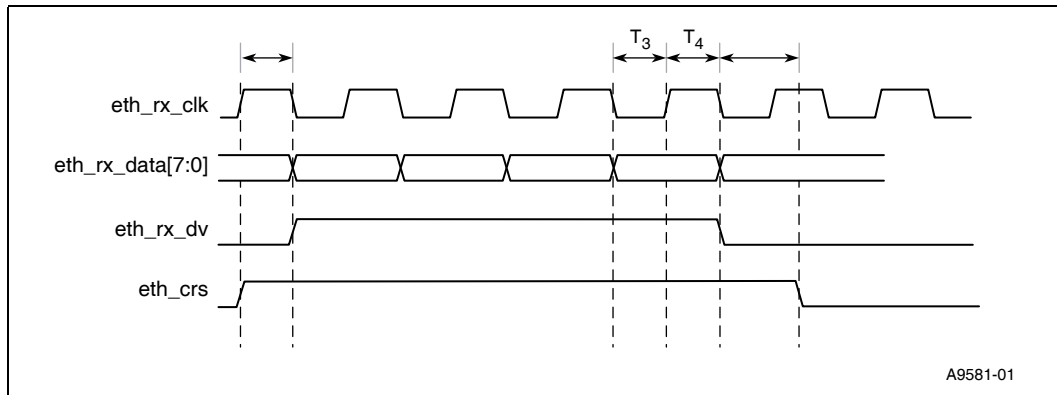

Table 51. MII Input Timings Values

Symbol	Parameter	Min.	Max.	Units	Notes
T ₃	ETH_RXDATA and ETH_RXDV setup time prior to rising edge of ETH_RXCLK	5.5		ns	1, 2
T ₄	ETH_RXDATA and ETH_RXDV hold time after the rising edge of ETH_RXCLK	0		ns	1, 2, 3

Notes:
 1. These values satisfy the MII specification requirement of 10-ns setup and hold time.
 2. Timing tests were performed with a 70-pF capacitor to ground.
 3. This parameter has been simulated but has not been fully tested.

5.5.2.5 MDIO

Figure 21. MDIO Output Timings

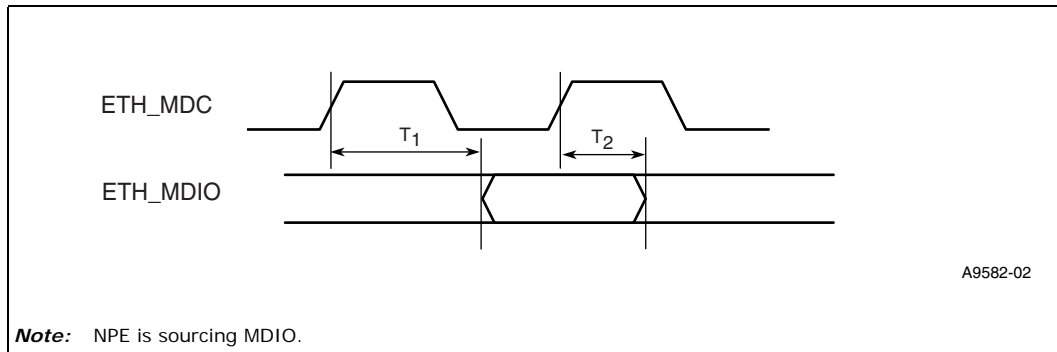

Note: NPE is sourcing MDIO.



Figure 22. MDIO Input Timings

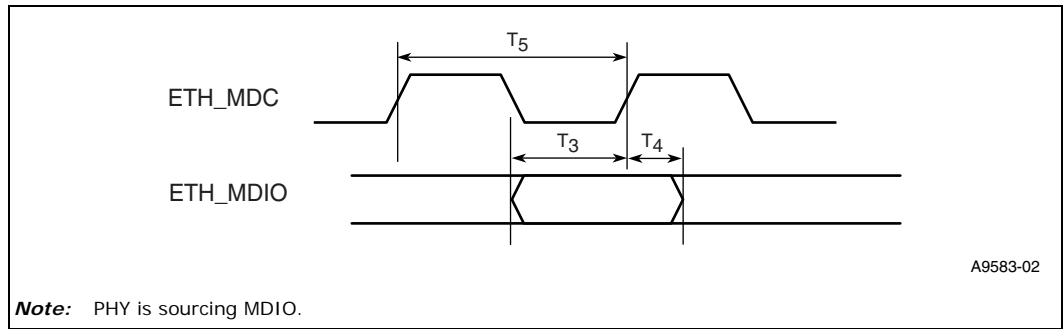

Table 52. MDIO Timings Values

Symbol	Parameter	Min.	Max.	Units	Notes
T1	ETH_MDIO, clock to output timing with respect to rising edge of ETH_MDC clock		ETH_MDC/2 + 10 ns	ns	
T2	ETH_MDIO output hold timing after the rising edge of ETH_MDC clock	10		ns	
T3	ETH_MDIO input setup prior to rising edge of ETH_MDC clock	2		ns	
T4	ETH_MDIO hold time after the rising edge of ETH_MDC clock	0		ns	1
T5	ETH_MDC clock period	125	500	ns	

Note:
1. This parameter is guaranteed by design but has not been 100% tested.

5.5.2.6 SDRAM Bus

Figure 23. SDRAM Input Timings

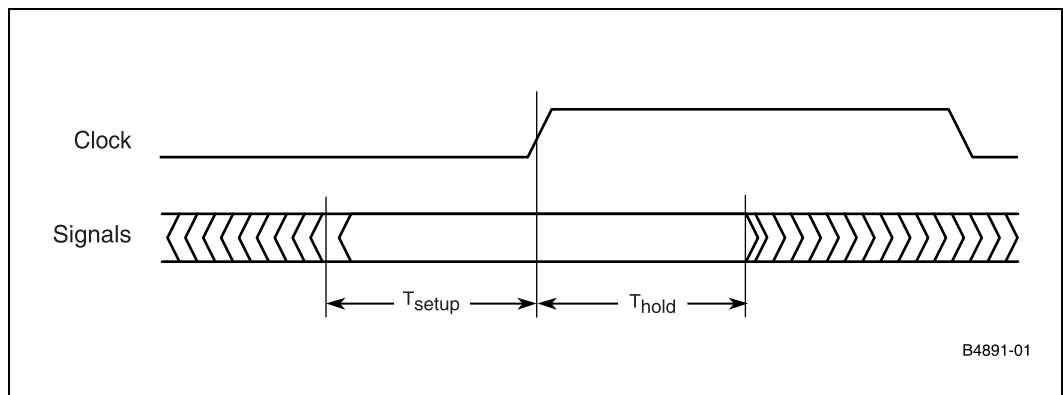

Table 53. SDRAM Input Timings Values

Symbol	Parameter	Min.	Max.	Units	Notes
T _{setup}	Input setup prior to rising edge of clock. Inputs included in this timing are SDM_DQ[31:0] (during a read operation).	1.4		ns	
T _{hold}	Input hold time after the rising edge of the clock. Inputs included in this timing are SDM_DQ[31:0] (during a read operation).	1.5		ns	

Figure 24. SDRAM Output Timings

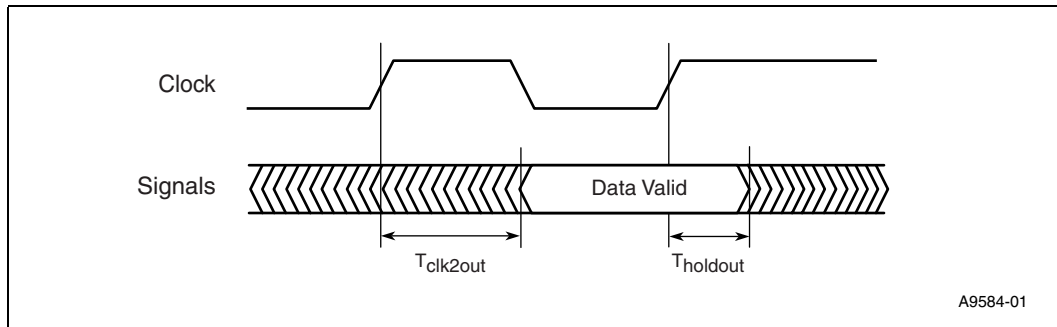

Table 54. SDRAM Output Timings Values

Symbol	Parameter	Min.	Max.	Units	Notes
$T_{clk2out}$	Rising edge of clock-to-signal output. Outputs included in this timing are SDM_ADDR[12:0], SDM_BA[1:0], SDM_DQM[3:0], SDM_CKE, SDM_WE_N, SDM_CS_N[1:0], SDM_CAS_N, SDM_RAS_N, SDM_DQ[31:0] (during a write operation).		5.5	ns	1
$T_{holdout}$	Signal output hold time after the rising edge of the clock. Outputs included in this timing are SDM_DQ[31:0] (during a write operation).	1.5		ns	1
Note:					
1. Timing test were performed with a 70-pF load to ground.					



5.5.2.7 Expansion Bus

Figure 25. Signal Timing With Respect to Clock Rising Edge

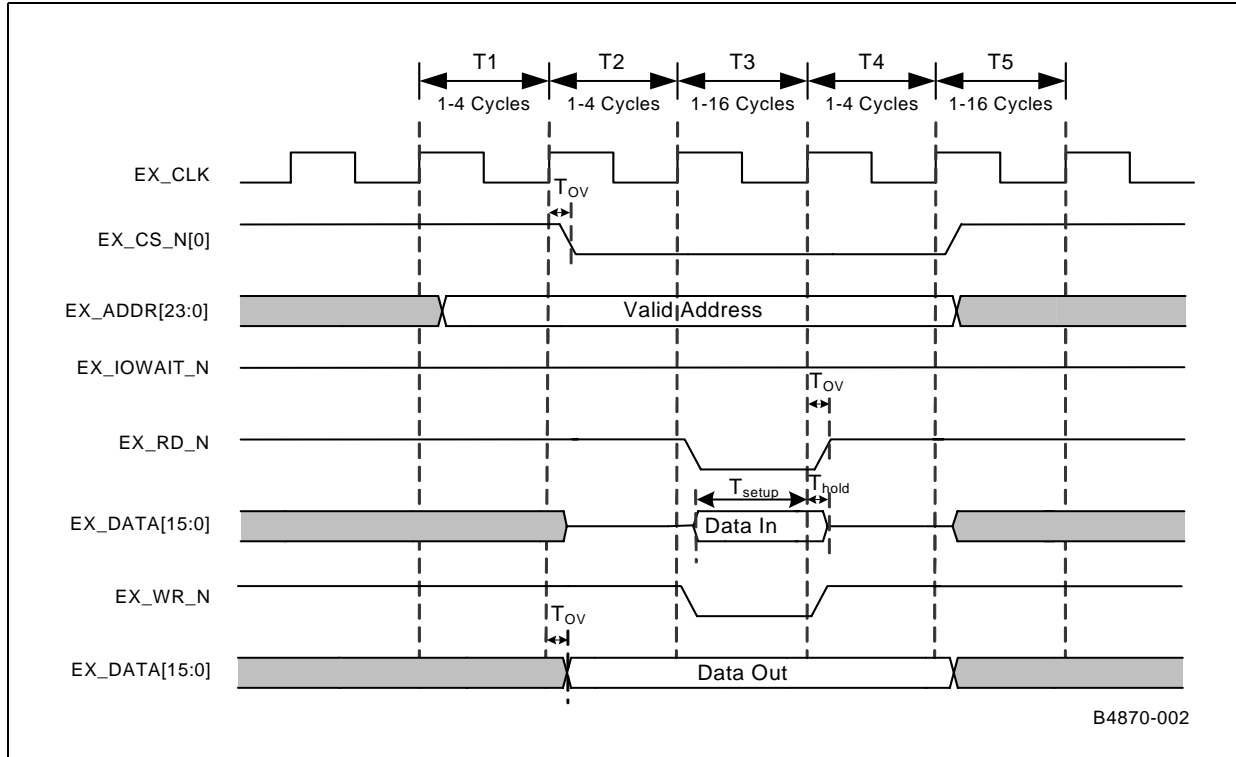

Table 55. Signal Timing With Respect to Clock Rising Edge

Symbol	Description	Min.	Max.	Units	Notes
T _{ov}	Control signal and data output valid after clock rising edge		15	ns	
T _{setup}	Input Setup time with respect to clock rising edge.	3		ns	1
T _{hold}	Input Hold time with respect to clock rising edge.	2		ns	1
Note:					
1. The Setup and Hold Timing Values are for all modes.					



Figure 26. Intel® Multiplexed Read Mode

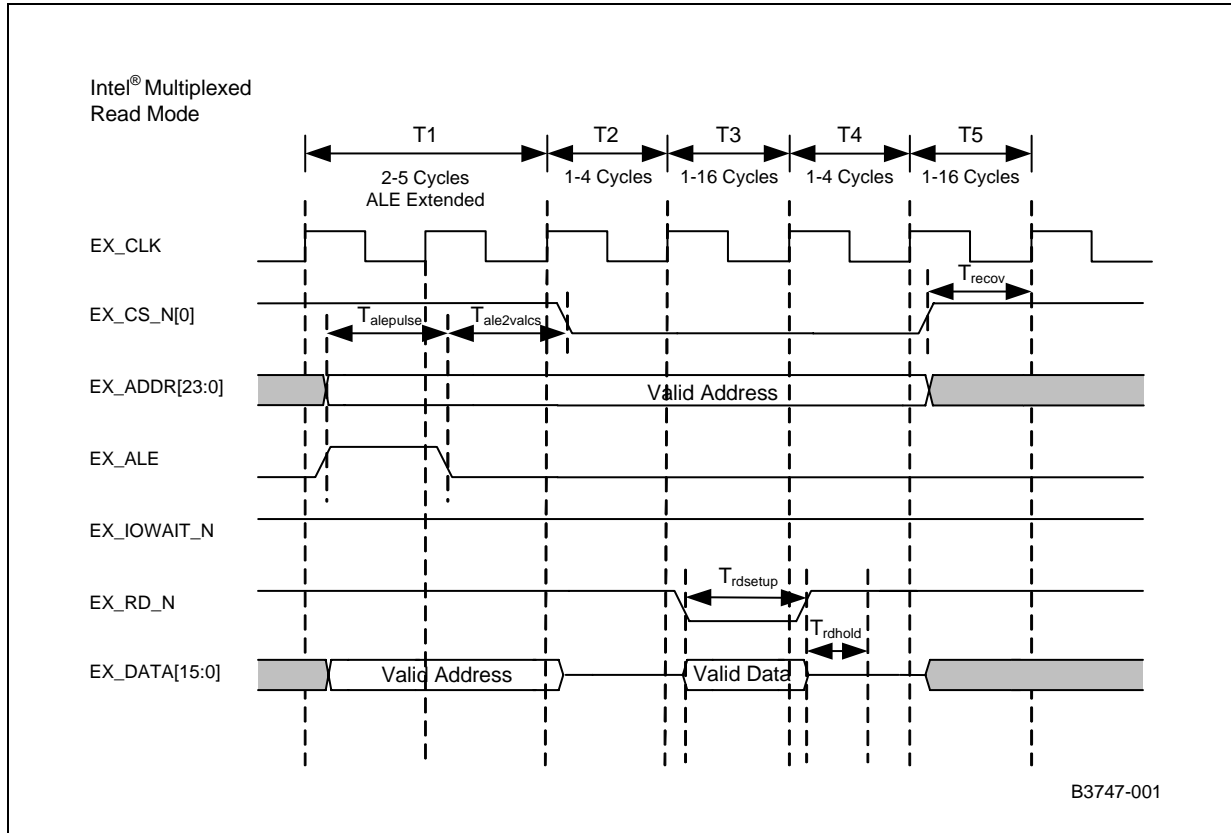



Figure 27. Intel® Multiplexed Write Mode

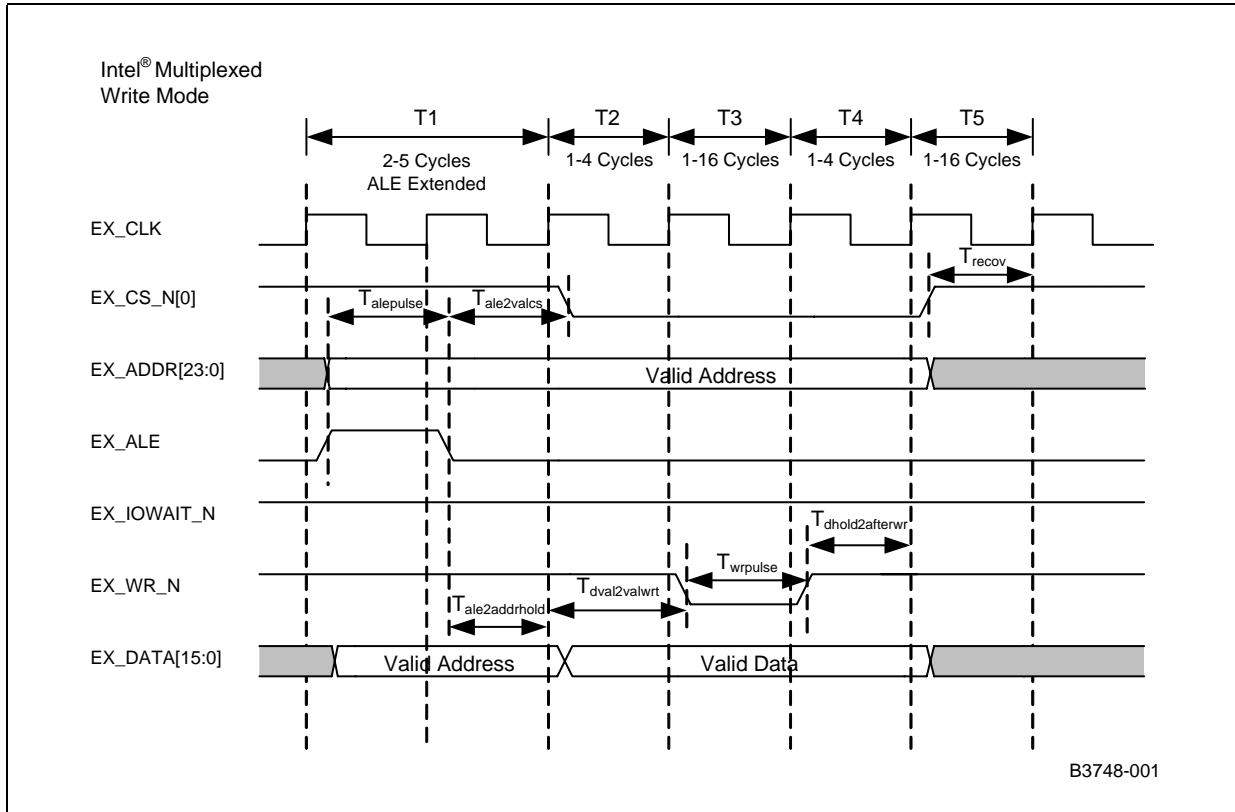



Table 56. Intel® Multiplexed Mode Values

Symbol	Parameter	Min.	Max.	Units	Notes
Talepulse	Pulse width of EX_ALE (ADDR is valid at the rising edge of EX_ALE)	1	4	Cycles	1, 7
Tale2addrhold	Valid address hold time after from falling edge of EX_ALE	1	1	Cycles	1, 2, 7
Tdval2valwrt	Write data valid prior to EX_WR_N falling edge	1	4	Cycles	3, 7
Twrpulse	Pulse width of the EX_WR_N	1	16	Cycles	4, 7
Tdholdafterwr	Valid data after the rising edge of EX_WR_N	1	4	Cycles	5, 7
Tale2valcs	Valid chip select after the falling edge of EX_ALE	1	4	Cycles	7
Trdsetup	Data valid required before the rising edge of EX_RD_N	15		ns	
Trdhold	Data hold required after the rising edge of EX_RD_N	0		ns	
Trecov	Time needed between successive accesses on expansion interface.	1	16	Cycles	6
<p>Notes:</p> <ol style="list-style-type: none"> 1. The EX_ALE signal is extended from 1 to 4 cycles based on the programming of the T1 timing parameter. The parameter Tale2addrhold is fixed at 1 cycle. 2. Setting the address phase parameter (T1) will adjust the duration that the address appears to the external device. 3. Setting the data setup phase parameter (T2) will adjust the duration that the data appears prior to a data strobe (read or write) to an external device. 4. Setting the data strobe phase parameter (T3) will adjust the duration that the data strobe appears (read or write) to an external device. Data will be available during this time as well. 5. Setting the data hold strobe phase parameter (T4) will adjust the duration that the chip selects, address, and data (during a write) will be held. 6. Setting the recovery phase parameter (T5) will adjust the duration between successive accesses on the expansion interface. 7. One cycle is the period of the Expansion Bus clock. 8. Clock to output delay for all signals will be a maximum of 15 ns for devices requiring operation in synchronous mode. 9. Timing tests were performed with a 70-pF capacitor to ground. 					



Figure 28. Intel® Simplex Read Mode

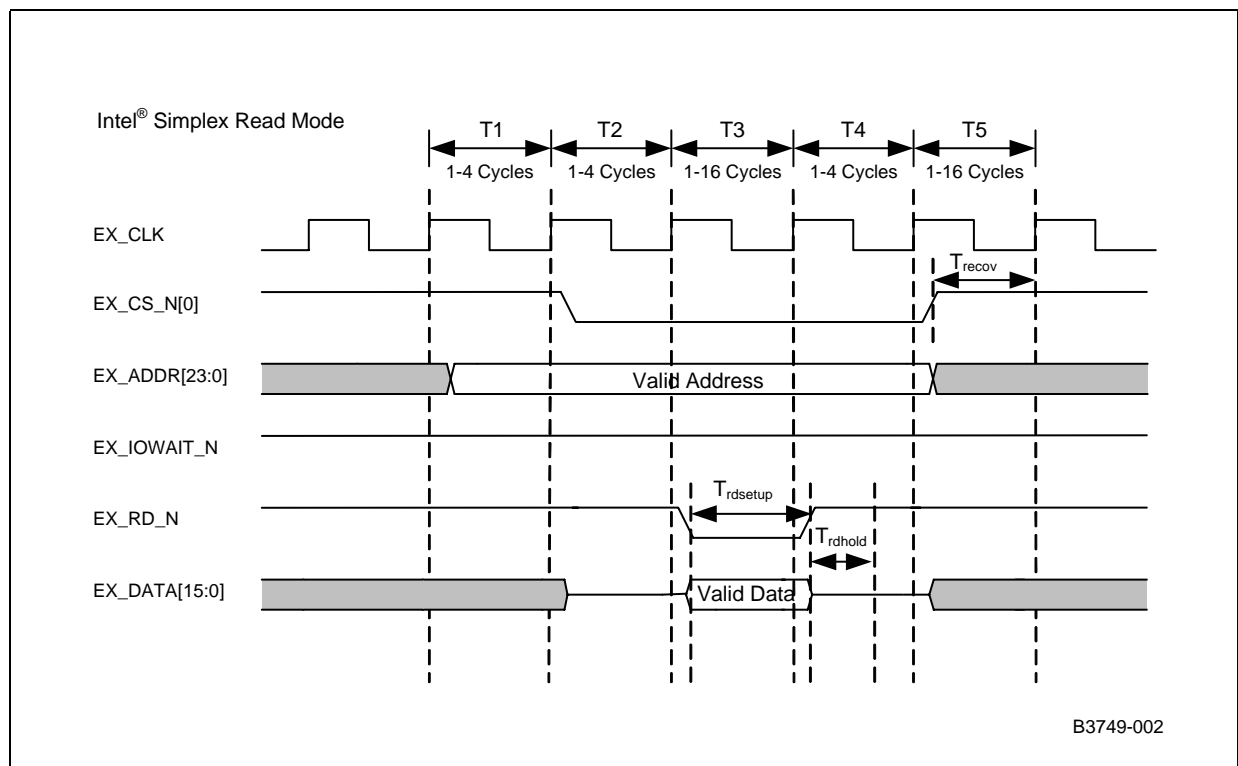

Figure 29. Intel® Simplex Write Mode

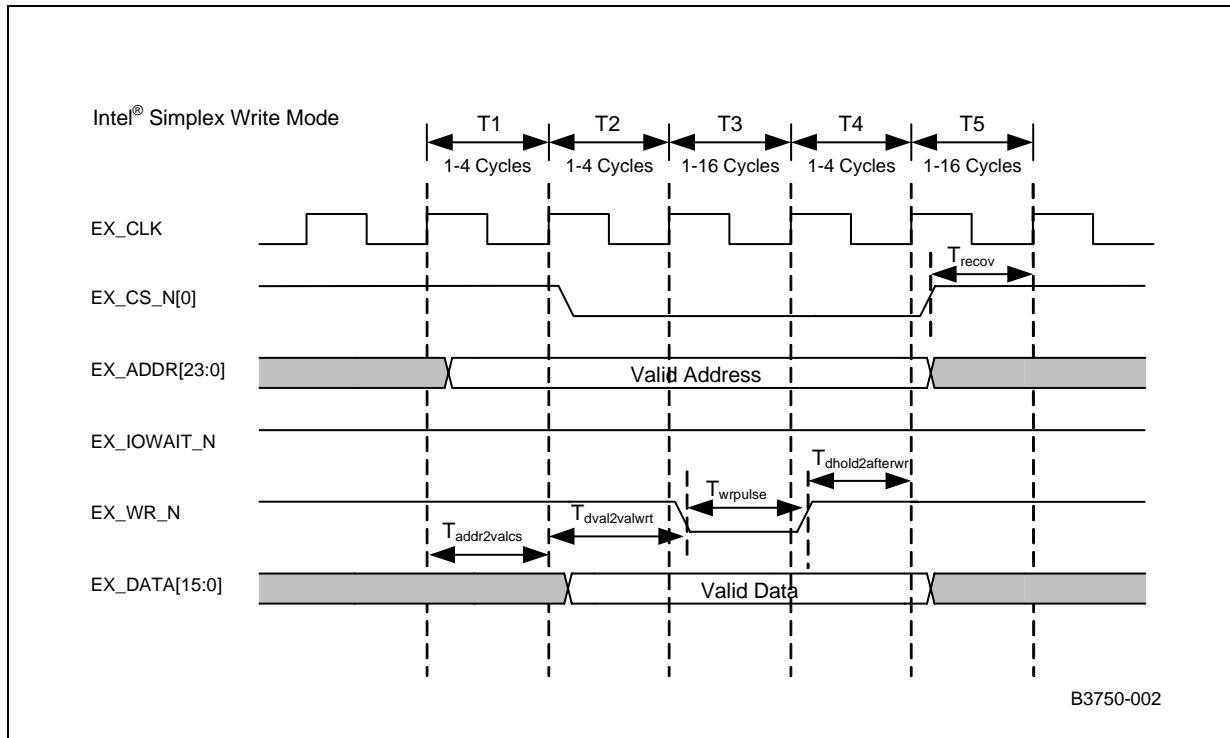



Table 57. Intel Simplex Mode Values

Symbol	Parameter	Min.	Max.	Units	Notes
T _{addr2valcs}	Valid address to valid chip select	1	4	Cycles	1, 2, 7
T _{dval2valwrt}	Write data valid prior to EX_WR_N falling edge	1	4	Cycles	3, 7
T _{wrpulse}	Pulse width of the EX_WR_N	1	16	Cycles	4, 7
T _{dholderwrt}	Valid data after the rising edge of EX_WR_N	1	4	Cycles	5, 7
T _{rdsetup}	Data valid required before the rising edge of EX_RD_N	15		ns	
T _{rdhold}	Data hold required after the rising edge of EX_RD_N	0		ns	
T _{recov}	Time required between successive accesses on the expansion interface.	1	16	Cycles	6
<p>Notes:</p> <ol style="list-style-type: none"> EX_ALE is not valid in simplex mode of operation. Setting the address phase parameter (T1) will adjust the duration that the address appears to the external device. Setting the data setup phase parameter (T2) will adjust the duration that the data appears prior to a data strobe (read or write) to an external device. Setting the data strobe phase parameter (T3) will adjust the duration that the data strobe appears (read or write) to an external device. Data will be available during this time as well. Setting the data hold strobe phase parameter (T4) will adjust the duration that the chip selects, address, and data (during a write) will be held. Setting the recovery phase parameter (T5) will adjust the duration between successive accesses on the expansion interface. One cycle is the period of the Expansion Bus clock. Clock to output delay for all signals will be a maximum of 15 ns for devices requiring operation in synchronous mode. Timing tests were performed with a 70-pF capacitor to ground. 					

Figure 30. Motorola* Multiplexed Read Mode

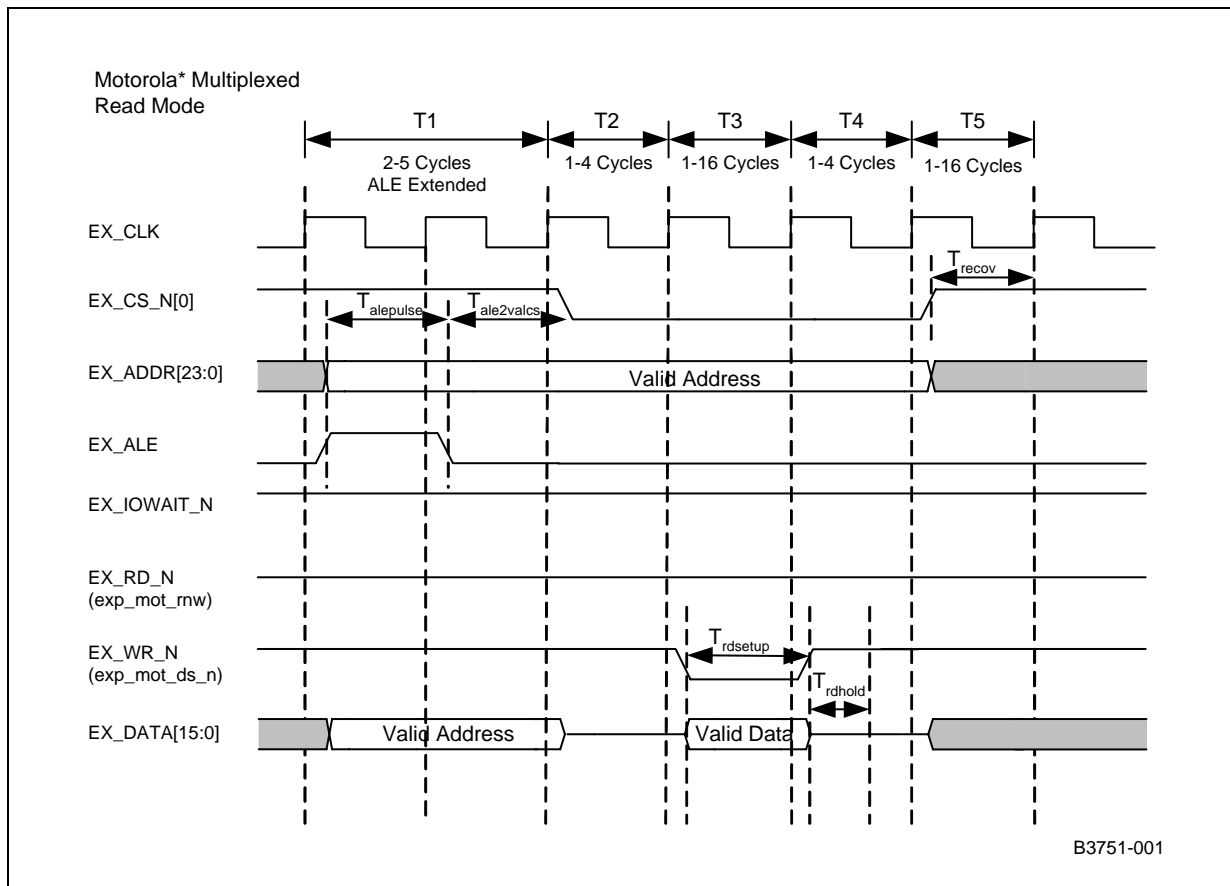
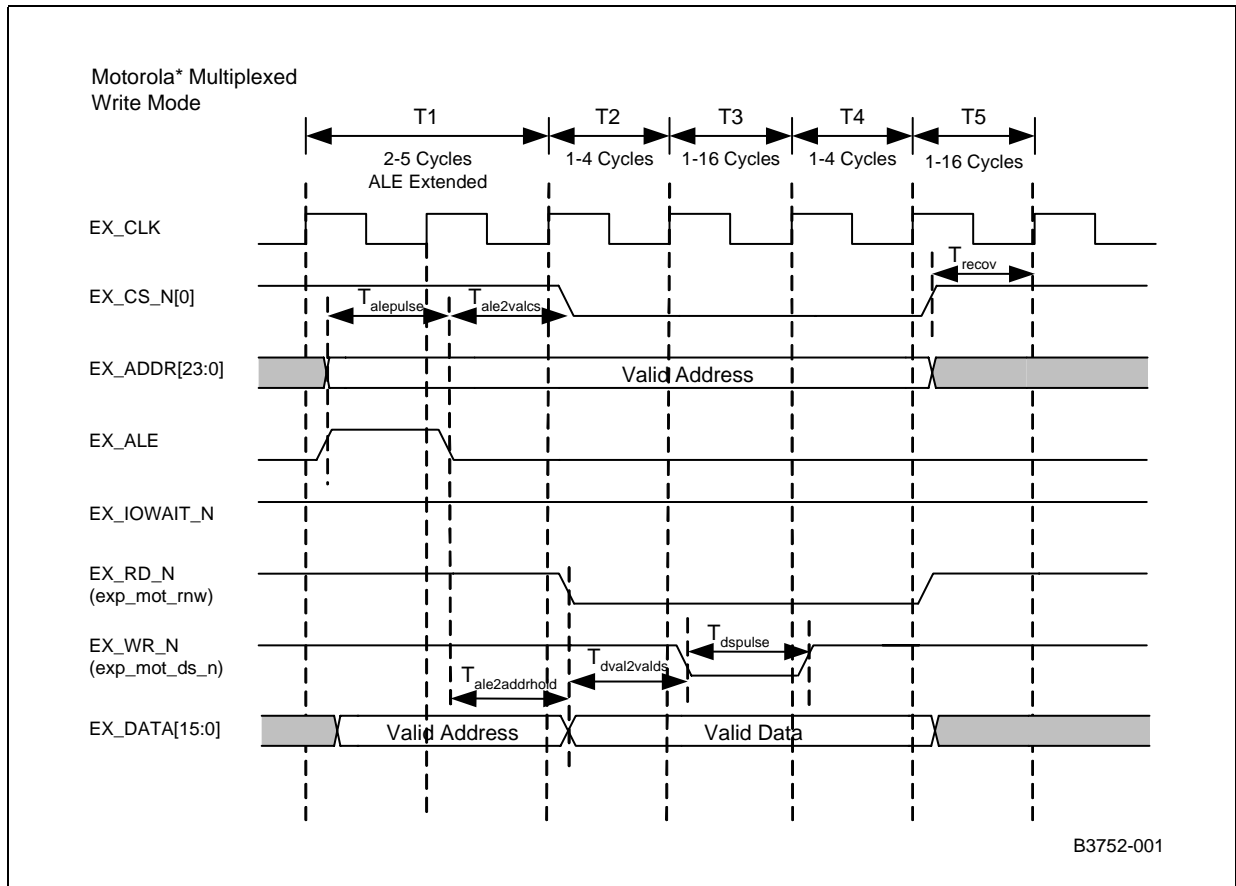



Figure 31. Motorola* Multiplexed Write Mode



B3752-001

Table 58. Motorola* Multiplexed Mode Values (Sheet 1 of 2)

Symbol	Parameter	Min.	Max.	Units	Notes
$T_{alepulse}$	Pulse width of EX_ALE (ADDR is valid at the rising edge of EX_ALE)	1	4	Cycles	1, 7
$T_{ale2addrhold}$	Valid address hold time after from falling edge of EX_ALE	1	1	Cycles	1, 2, 7
$T_{dval2valds}$	Write data valid prior to EXP_MOT_DS_N falling edge	1	4	Cycles	3, 7
$T_{dspulse}$	Pulse width of the EXP_MOT_DS_N	1	16	Cycles	4, 7

Notes:

- The EX_ALE signal is extended from 1 to 4 cycles based on the programming of the T1 timing parameter. The parameter Tale2addrhold is fixed at 1 cycle.
- Setting the address phase parameter (T1) will adjust the duration that the address appears to the external device.
- Setting the data setup phase parameter (T2) will adjust the duration that the data appears prior to a data strobe (read or write) to an external device.
- Setting the data strobe phase parameter (T3) will adjust the duration that the data strobe appears (read or write) to an external device. Data will be available during this time as well.
- Setting the data hold strobe phase parameter (T4) will adjust the duration that the chip selects, address, and data (during a write) will be held.
- Setting the recovery phase parameter (T5) will adjust the duration between successive accesses on the expansion interface.
- One cycle is the period of the Expansion Bus clock.
- Clock to output delay for all signals will be a maximum of 15 ns for devices requiring operation in synchronous mode.
- Timing tests were performed with a 70-pF capacitor to ground.

Table 58. Motorola* Multiplexed Mode Values (Sheet 2 of 2)

Symbol	Parameter	Min.	Max.	Units	Notes
$T_{dholdafterds}$	Valid data after the rising edge of EXP_MOT_DS_N	1	4	Cycles	5, 7
$T_{ale2valcs}$	Valid chip select after the falling edge of EX_ALE	1	4	Cycles	7
$T_{rdsetup}$	Data valid required before the rising edge of EXP_MOT_DS_N	15		ns	
T_{rdhold}	Data hold required after the rising edge of EXP_MOT_DS_N	0		ns	
T_{recov}	Time needed between successive accesses on expansion interface.	1	16	Cycles	6

Notes:

- The EX_ALE signal is extended from 1 to 4 cycles based on the programming of the T1 timing parameter. The parameter Tale2addrhold is fixed at 1 cycle.
- Setting the address phase parameter (T1) will adjust the duration that the address appears to the external device.
- Setting the data setup phase parameter (T2) will adjust the duration that the data appears prior to a data strobe (read or write) to an external device.
- Setting the data strobe phase parameter (T3) will adjust the duration that the data strobe appears (read or write) to an external device. Data will be available during this time as well.
- Setting the data hold strobe phase parameter (T4) will adjust the duration that the chip selects, address, and data (during a write) will be held.
- Setting the recovery phase parameter (T5) will adjust the duration between successive accesses on the expansion interface.
- One cycle is the period of the Expansion Bus clock.
- Clock to output delay for all signals will be a maximum of 15 ns for devices requiring operation in synchronous mode.
- Timing tests were performed with a 70-pF capacitor to ground.

Figure 32. Motorola* Simplex Read Mode

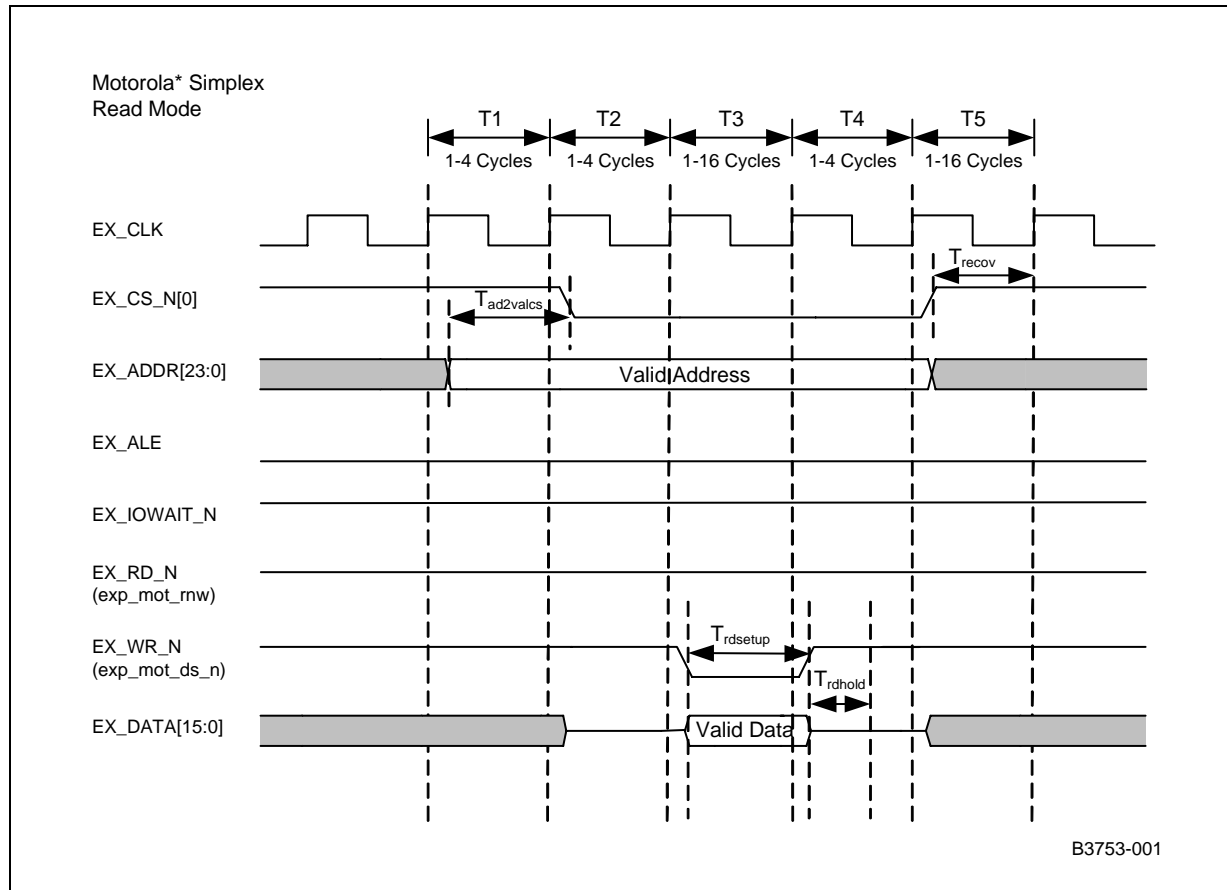
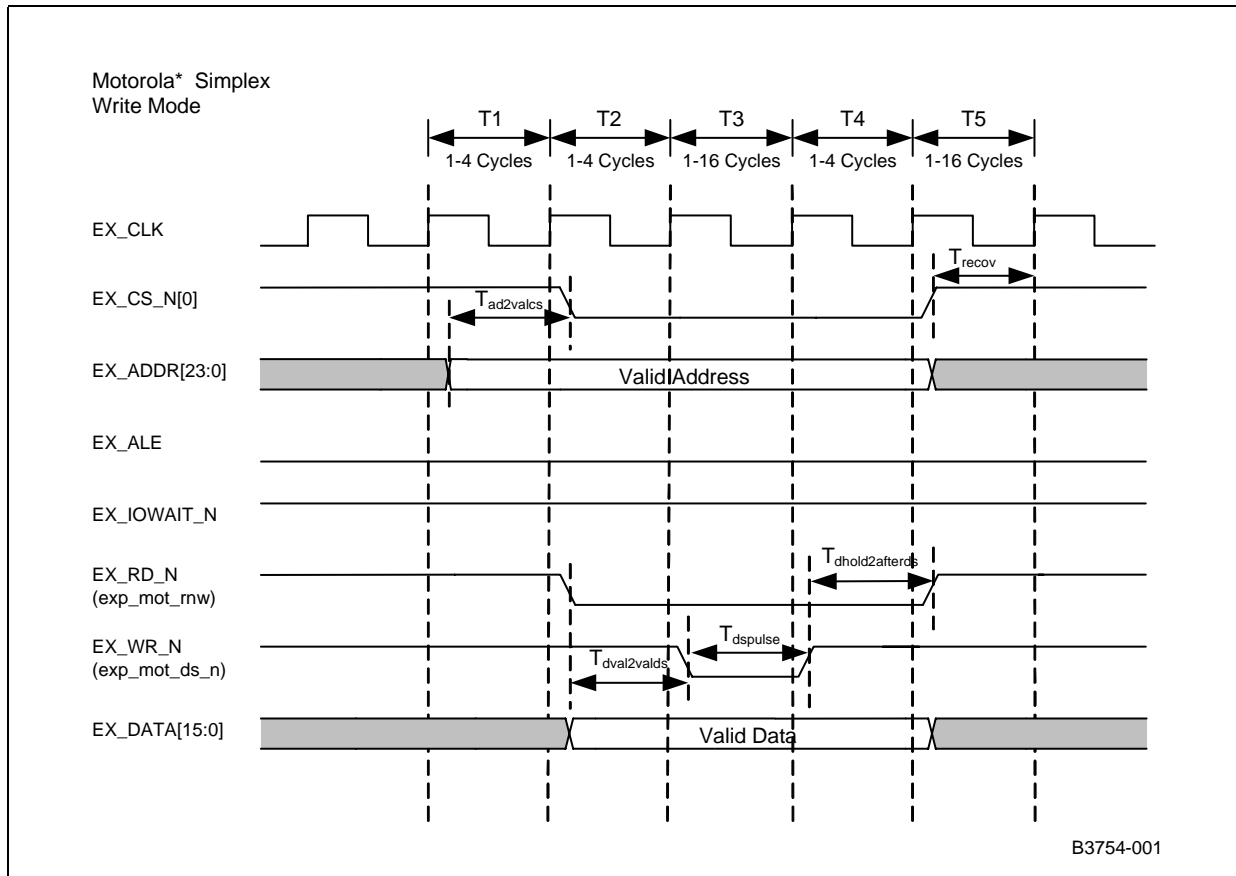



Figure 33. Motorola* Simplex Write Mode



B3754-001

Table 59. Motorola* Simplex Mode Values (Sheet 1 of 2)

Symbol	Parameter	Min.	Max.	Units	Notes
$T_{ad2valcs}$	Valid address to valid chip select	1	4	Cycles	1, 2, 7
$T_{dval2valds}$	Write data valid prior to EXP_MOT_DS_N falling edge	1	4	Cycles	3, 7
$T_{dspulse}$	Pulse width of the EXP_MOT_DS_N	1	16	Cycles	4, 7
$T_{dhold2afterds}$	Valid data after the rising edge of EXP_MOT_DS_N	1	4	Cycles	5, 7

Notes:

- EX_ALE is not valid in simplex mode of operation.
- Setting the address phase parameter (T1) will adjust the duration that the address appears to the external device.
- Setting the data setup phase parameter (T2) will adjust the duration that the data appears prior to a data strobe (read or write) to an external device.
- Setting the data strobe phase parameter (T3) will adjust the duration that the data strobe appears (read or write) to an external device. Data will be available during this time as well.
- Setting the data hold strobe phase parameter (T4) will adjust the duration that the chip selects, address, and data (during a write) will be held.
- Setting the recovery phase parameter (T5) will adjust the duration between successive accesses on the expansion interface.
- One cycle is the period of the Expansion Bus clock.
- Clock to output delay for all signals will be a maximum of 15 ns for devices requiring operation in synchronous mode.
- Timing tests were performed with a 70-pF capacitor to ground.



Table 59. Motorola* Simplex Mode Values (Sheet 2 of 2)

Symbol	Parameter	Min.	Max.	Units	Notes
$T_{rdsetup}$	Data valid required before the rising edge of EXP_MOT_DS_N	15		ns	
T_{rdhold}	Data hold required after the rising edge of EXP_MOT_DS_N	0		ns	
T_{recov}	Time required between successive accesses on the expansion interface.	1	16	Cycles	6
<p>Notes:</p> <ol style="list-style-type: none"> EX_ALE is not valid in simplex mode of operation. Setting the address phase parameter (T1) will adjust the duration that the address appears to the external device. Setting the data setup phase parameter (T2) will adjust the duration that the data appears prior to a data strobe (read or write) to an external device. Setting the data strobe phase parameter (T3) will adjust the duration that the data strobe appears (read or write) to an external device. Data will be available during this time as well. Setting the data hold strobe phase parameter (T4) will adjust the duration that the chip selects, address, and data (during a write) will be held. Setting the recovery phase parameter (T5) will adjust the duration between successive accesses on the expansion interface. One cycle is the period of the Expansion Bus clock. Clock to output delay for all signals will be a maximum of 15 ns for devices requiring operation in synchronous mode. Timing tests were performed with a 70-pF capacitor to ground. 					

Figure 35. HPI-8 Mode Write Accesses

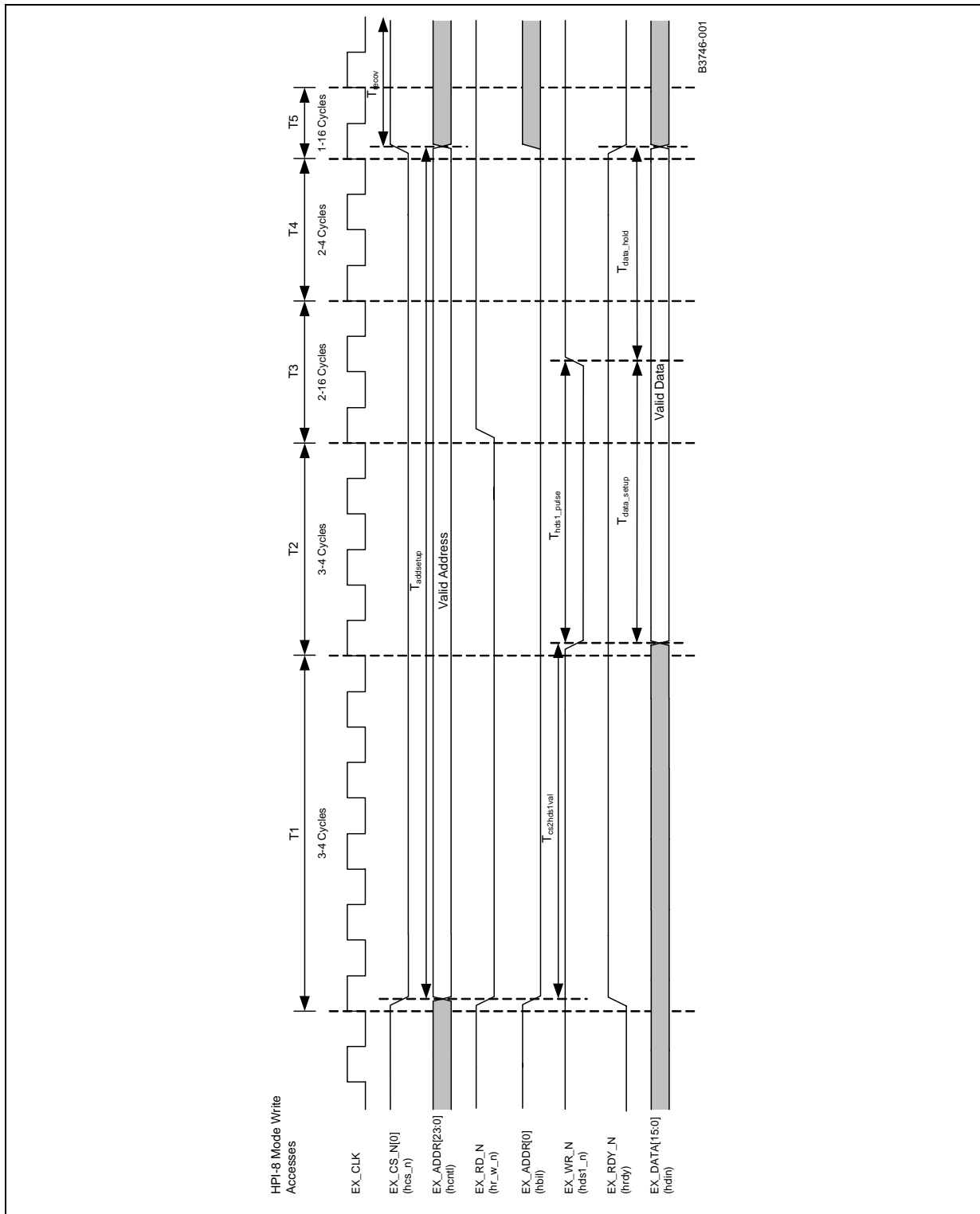



Table 60. HPI Timing Symbol Description

State	Description	Min.	Max.	Unit	Notes
T1	Address Timing	3	4	Cycles	1, 5, 6
T2	Setup/Chip Select Timing	3	4	Cycles	2, 6
T3	Strobe Timing	2	16	Cycles	3, 5, 6
T4	Hold Timing	3	4	Cycles	6
T5	Recovery Phase	2	17	Cycles	6
<p>Notes:</p> <ol style="list-style-type: none"> The address phase parameter (T1) must be set to a minimum value of 2. This value allows three T clocks for the address phase. This setting is required to ensure that in the event of an HRDY, the Intel® IXP42X Product Line and Intel® IXC1100 Control Plane processors has had sufficient time to recognize the HRDY and hold the address phase for at least one clock pulse after the HRDY is de-active. The data setup phase parameter (T2) must be set to a minimum value of 2. This value allows three T clocks for setup phase. The data strobe phase parameter (T3) must be set to a minimum value of 1. This value allows two T clocks for the data phase. This setting is required to ensure that in the event of an HRDY, the Intel® IXP42X Product Line and Intel® IXC1100 Control Plane processors has had sufficient time to recognize the HRDY and hold the data setup phase for at least one clock pulse after the HRDY is de-active. Setting the recovery phase parameter (T5) will adjust the duration between successive accesses on the Expansion Bus interface. HRDY can be asserted by the DSP at any point in the access. The interface will not leave states T1 or T3 until HRDY is de-active. One cycle is the period of the Expansion Bus clock. Timing tests were performed with a 70-pF capacitor to ground. 					

Table 61. HPI-8 Mode Write Access Values

Symbol	Parameter	Min.	Max.	Units	Notes
T _{add_setup}	Valid time that address is asserted on the line. The address is asserted at the same time as chip select.	11	45	Cycles	1, 5, 6
T _{cs2hds1val}	Delay from chip select being active and the HDS1 data strobe being active.	3	4	Cycles	5, 6
T _{hds1_pulse}	Pulse width of the HDS1 data strobe	4	5	Cycles	2, 4, 5
T _{data_setup}	Data valid prior to the rising edge of the HDS1 data strobe.	4	5	Cycles	3, 5, 6
T _{data_hold}	Data valid after the rising edge of the HDS1 data strobe.	4	36	Cycles	3, 6
T _{recov}	Time required between successive accesses on the expansion interface.	2	17	Cycles	4, 6
<p>Notes:</p> <ol style="list-style-type: none"> The address phase parameter (T1) must be set to a minimum value of 2. This value allows three T clocks for the address phase. This setting is required to ensure that in the event of an HRDY, the Intel® IXP42X Product Line and Intel® IXC1100 Control Plane processors has had sufficient time to recognize the HRDY and hold the address phase for at least one clock pulse after the HRDY is de-active. The data setup phase parameter (T2) must be set to a minimum value of 2. This value allows three T clocks for setup phase. The data strobe phase parameter (T3) must be set to a minimum value of 1. This value allows two T clocks for the data phase. This setting is required to ensure that in the event of an HRDY, the Intel® IXP42X Product Line and Intel® IXC1100 Control Plane processors has had sufficient time to recognize the HRDY and hold the data setup phase for at least one clock pulse after the HRDY is de-active. Setting the recovery phase parameter (T5) will adjust the duration between successive accesses on the Expansion Bus interface. HRDY can be asserted by the DSP at any point in the access. The interface will not leave states T1 or T3 until HRDY is de-active. One cycle is the period of the Expansion Bus clock. Timing tests were performed with a 70-pF capacitor to ground. 					



Table 62. HPI-16 Multiplexed Write Accesses Values

Symbol	Parameter	Min.	Max.	Units	Notes
T_{add_setup}	Valid time that address is asserted on the line. The address is asserted at the same time as chip select.	11	45	Cycles	1, 5, 6
$T_{cs2hds1val}$	Delay from chip select being active and the HDS1 data strobe being active.	3	4	Cycles	5, 6
T_{hds1_pulse}	Pulse width of the HDS1 data strobe.	4	5	Cycles	2, 4, 5
T_{data_setup}	Data valid prior to the rising edge of the HDS1 data strobe.	4	5	Cycles	3, 5, 6
T_{data_hold}	Data valid after the rising edge of the HDS1 data strobe.	4	36	Cycles	3, 6
T_{recov}	Time required between successive accesses on the expansion interface.	2	17	Cycles	4, 6
<p>Notes:</p> <ol style="list-style-type: none"> The address phase parameter (T1) must be set to a minimum value of 2. This value allows three T clocks for the address phase. This setting is required to ensure that in the event of an HRDY, the Intel® IXP42X Product Line and Intel® IXC1100 Control Plane processors has had sufficient time to recognize the HRDY and hold the address phase for at least one clock pulse after the HRDY is de-active. The data setup phase parameter (T2) must be set to a minimum value of 2. This value allows three T clocks for setup phase. The data strobe phase parameter (T3) must be set to a minimum value of 1. This value allows two T clocks for the data phase. This setting is required to ensure that in the event of an HRDY, the Intel® IXP42X Product Line and Intel® IXC1100 Control Plane processors has had sufficient time to recognize the HRDY and hold the data setup phase for at least one clock pulse after the HRDY is de-active. Setting the recovery phase parameter (T5) will adjust the duration between successive accesses on the Expansion Bus interface. HRDY can be asserted by the DSP at any point in the access. The interface will not leave states T1 or T3 until HRDY is de-active. One cycle is the period of the Expansion Bus clock. Timing tests were performed with a 70-pF capacitor to ground. 					



Figure 36. HPI-16 Multiplexed Write Mode

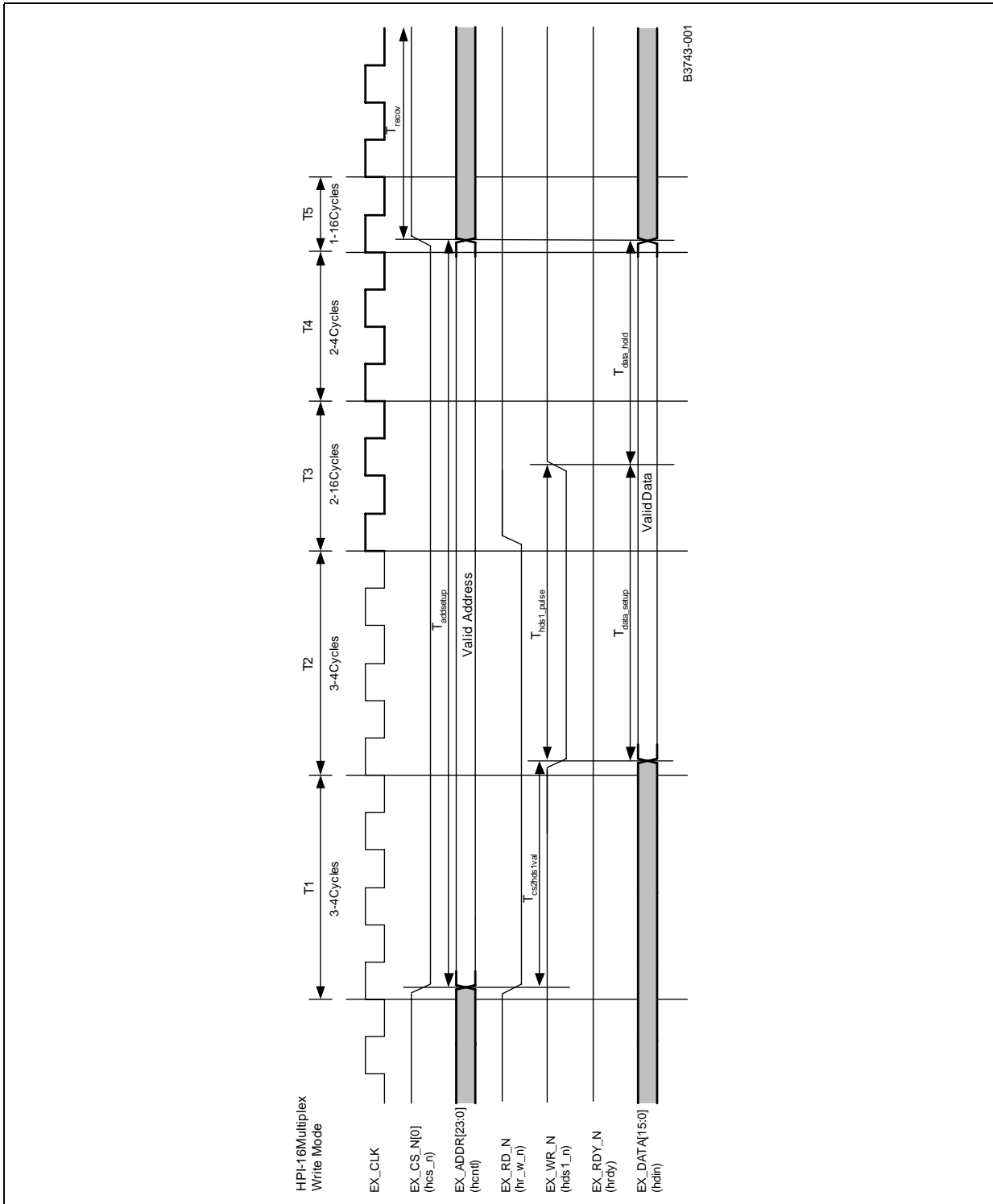



Table 63. HPI-16 Multiplexed Read Accesses Values

Symbol	Parameter	Min.	Max.	Units	Notes
T_{add_setup}	Valid time that address is asserted on the line. The address is asserted at the same time as chip select.	11	45	Cycles	1, 5, 6
$T_{cs2hds1val}$	Delay from chip select being active and the HDS1 data strobe being active.	3	4	Cycles	5, 6
T_{hds1_pulse}	Pulse width of the HDS1 data strobe.	4	5	Cycles	2, 4, 5
T_{data_setup}	Data is valid from the time from of the falling edge of HDS1_N to when the data is read.	4	5	Cycles	3, 5, 6
T_{recov}	Time required between successive accesses on the expansion interface.	2	17	Cycles	4, 6
<p>Notes:</p> <ol style="list-style-type: none"> The address phase parameter (T1) must be set to a minimum value of 2. This value allows three T clocks for the address phase. This setting is required to ensure that in the event of an HRDY, the Intel® IXP42X Product Line and Intel® IXC1100 Control Plane processors has had sufficient time to recognize the HRDY and hold the address phase for at least one clock pulse after the HRDY is de-active. The data setup phase parameter (T2) must be set to a minimum value of 2. This value allows three T clocks for setup phase. The data strobe phase parameter (T3) must be set to a minimum value of 1. This value allows two T clocks for the data phase. This setting is required to ensure that in the event of an HRDY, the Intel® IXP42X Product Line and Intel® IXC1100 Control Plane processors has had sufficient time to recognize the HRDY and hold the data setup phase for at least one clock pulse after the HRDY is de-active. Setting the recovery phase parameter (T5) will adjust the duration between successive accesses on the Expansion Bus interface. HRDY can be asserted by the DSP at any point in the access. The interface will not leave states T1 or T3 until HRDY is de-active. One cycle is the period of the Expansion Bus clock. Timing tests were performed with a 70-pF capacitor to ground. 					



Figure 37. HPI-16 Multiplex Read Mode

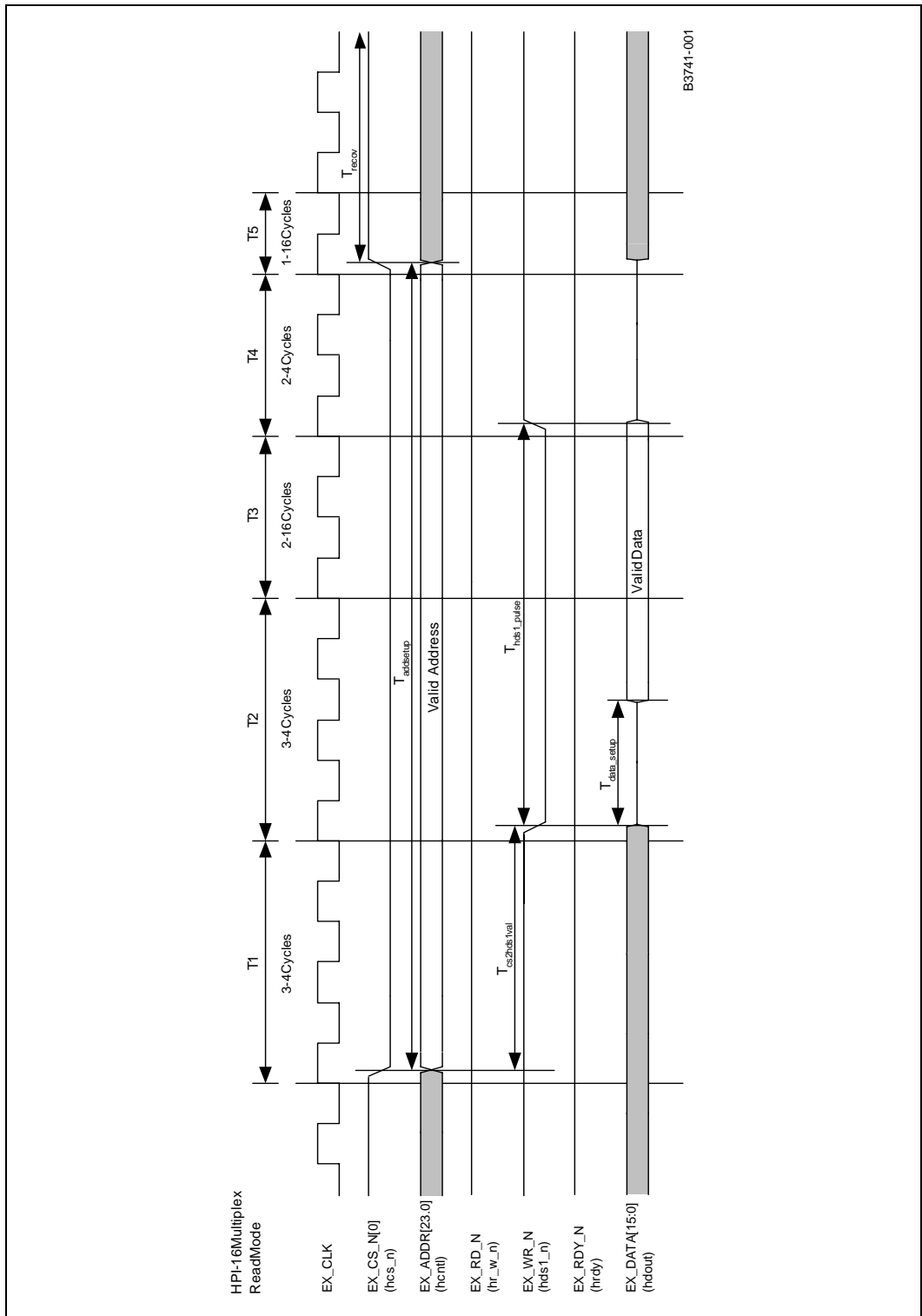



Table 64. HPI-16 Simplex Read Accesses Values

Symbol	Parameter	Min.	Max.	Units	Notes
T_{add_setup}	Valid time that address is asserted on the line. The address is asserted at the same time as chip select.	11	45	Cycles	1, 5, 6
$T_{cs2hds1val}$	Delay from chip select being active and the HDS1 data strobe being active.	3	4	Cycles	5, 6
T_{hds1_pulse}	Pulse width of the HDS1 data strobe.	4	5	Cycles	2, 4, 5
T_{data_setup}	Data is valid from the time from of the falling edge of HDS1_N to when the data is read.	4	5	Cycles	3, 5, 6
T_{recov}	Time required between successive accesses on the expansion interface.	2	17	Cycles	4, 6
<p>Notes:</p> <ol style="list-style-type: none"> The address phase parameter (T1) must be set to a minimum value of 2. This value allows three T clocks for the address phase. This setting is required to ensure that in the event of an HRDY, the Intel® IXP42X Product Line and Intel® IXC1100 Control Plane processors has had sufficient time to recognize the HRDY and hold the address phase for at least one clock pulse after the HRDY is de-active. The data setup phase parameter (T2) must be set to a minimum value of 2. This value allows three T clocks for setup phase. The data strobe phase parameter (T3) must be set to a minimum value of 1. This value allows two T clocks for the data phase. This setting is required to ensure that in the event of an HRDY, the Intel® IXP42X Product Line and Intel® IXC1100 Control Plane processors has had sufficient time to recognize the HRDY and hold the data setup phase for at least one clock pulse after the HRDY is de-active. Setting the recovery phase parameter (T5) will adjust the duration between successive accesses on the Expansion Bus interface. HRDY can be asserted by the DSP at any point in the access. The interface will not leave states T1 or T3 until HRDY is de-active. One cycle is the period of the Expansion Bus clock. Timing tests were performed with a 70-pF capacitor to ground. 					



Figure 38. HPI-16 Simplex Read Mode

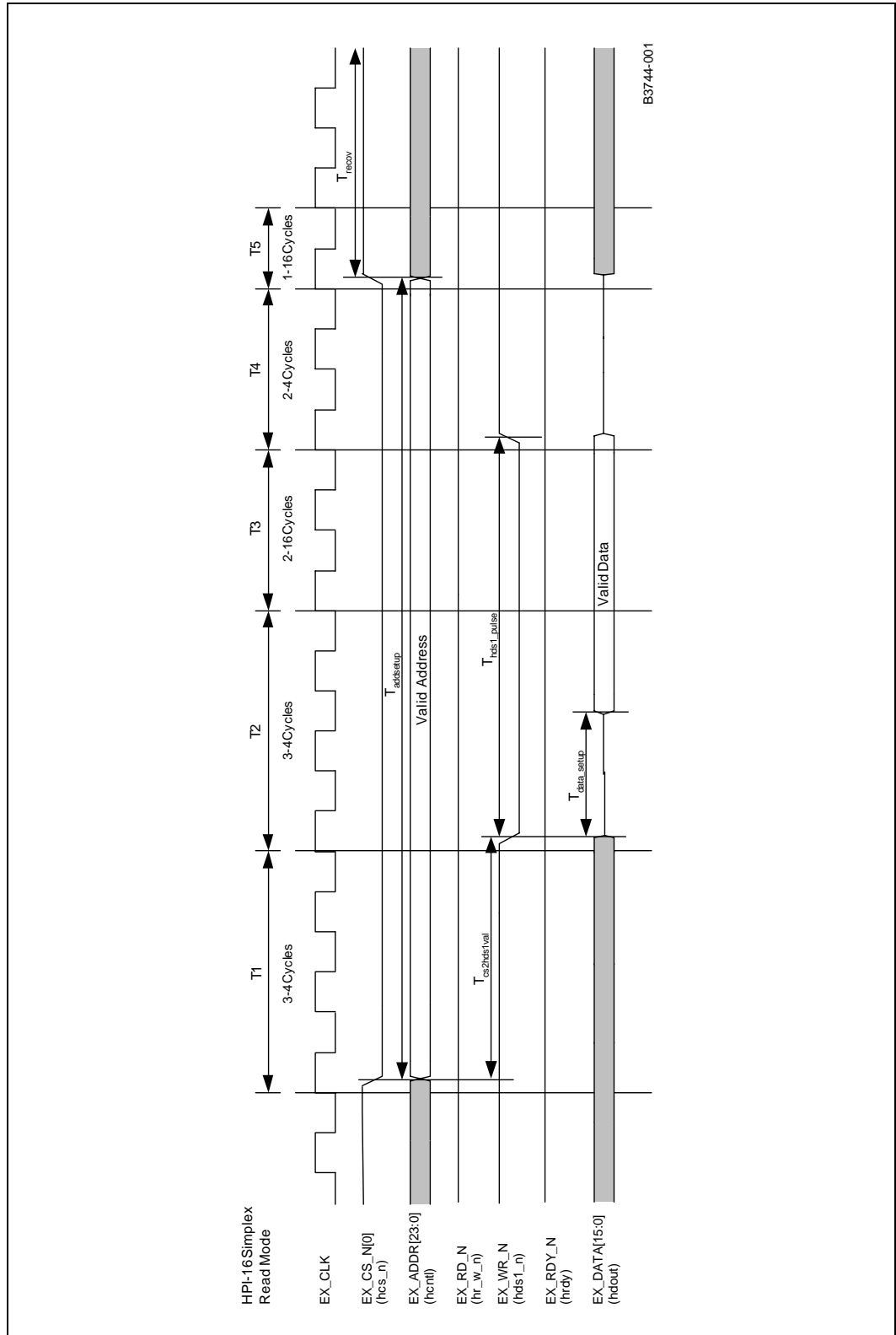

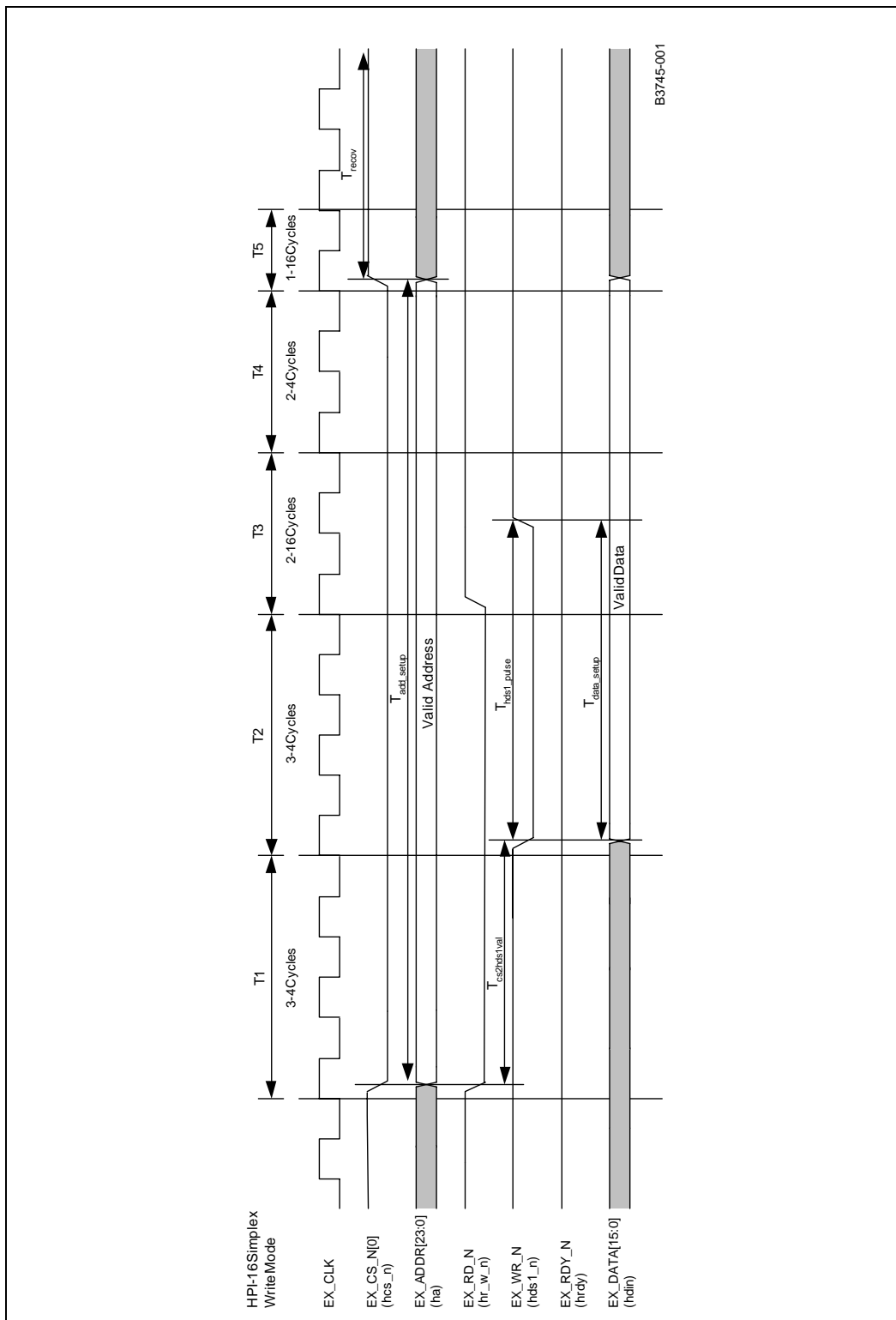

Table 65. HPI-16 Simplex Write Accesses Values

Symbol	Parameter	Min.	Max.	Units	Notes
T_{add_setup}	Valid time that address is asserted on the line. The address is asserted at the same time as chip select.	11	45	Cycles	1, 5, 6
$T_{cs2hds1val}$	Delay from chip select being active and the HDS1 data strobe being active.	3	4	Cycles	5, 6
T_{hds1_pulse}	Pulse width of the HDS1 data strobe.	4	5	Cycles	2, 4, 5
T_{data_setup}	Data valid prior to the rising edge of the HDS1 data strobe.	4	5	Cycles	3, 5, 6
T_{data_hold}	Data valid after the rising edge of the HDS1 data strobe.	4	36	Cycles	3, 6
T_{recov}	Time required between successive accesses on the expansion interface.	2	17	Cycles	4, 6
<p>Notes:</p> <ol style="list-style-type: none"> The address phase parameter (T1) must be set to a minimum value of 2. This value allows three T clocks for the address phase. This setting is required to ensure that in the event of an HRDY, the Intel® IXP42X Product Line and Intel® IXC1100 Control Plane processors has had sufficient time to recognize the HRDY and hold the address phase for at least one clock pulse after the HRDY is de-active. The data setup phase parameter (T2) must be set to a minimum value of 2. This value allows three T clocks for setup phase. The data strobe phase parameter (T3) must be set to a minimum value of 1. This value allows two T clocks for the data phase. This setting is required to ensure that in the event of an HRDY, the Intel® IXP42X Product Line and Intel® IXC1100 Control Plane processors has had sufficient time to recognize the HRDY and hold the data setup phase for at least one clock pulse after the HRDY is de-active. Setting the recovery phase parameter (T5) will adjust the duration between successive accesses on the Expansion Bus interface. HRDY can be asserted by the DSP at any point in the access. The interface will not leave states T1 or T3 until HRDY is de-active. One cycle is the period of the Expansion Bus clock. Timing tests were performed with a 70-pF capacitor to ground. 					



Figure 39. HPI-16 Simplex Write Mode



5.5.2.7.1 EX_IOWAIT_N

The EX_IOWAIT_N signal is available to be shared by devices attached to chip selects 0 through 7, when configured in Intel or Motorola modes of operation. The main purpose of this signal is to properly communicate with slower devices requiring more time to respond during data access. During idle cycles, the board is responsible for ensuring that EX_IOWAIT_N is pulled-up. The Expansion bus controller will always ignore EX_IOWAIT_N for synchronous Intel mode writes.

Refer to the Using I/O Wait sub-section in the Expansion Bus Controller chapter of the *Intel® IXP42X Product Line of Network Processors and IXC1100 Control Plane Processor Developer's Manual* for detailed information.

Figure 40. I/O Wait Normal Phase Timing

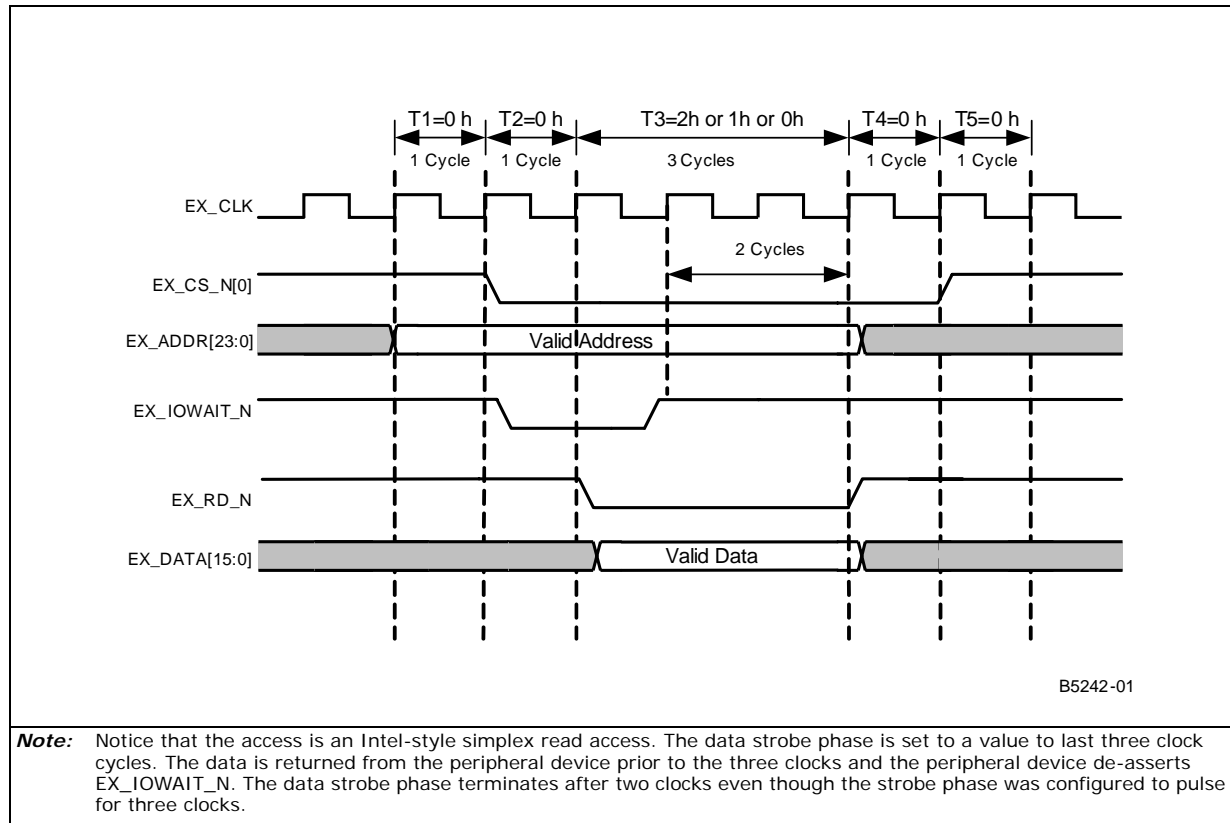
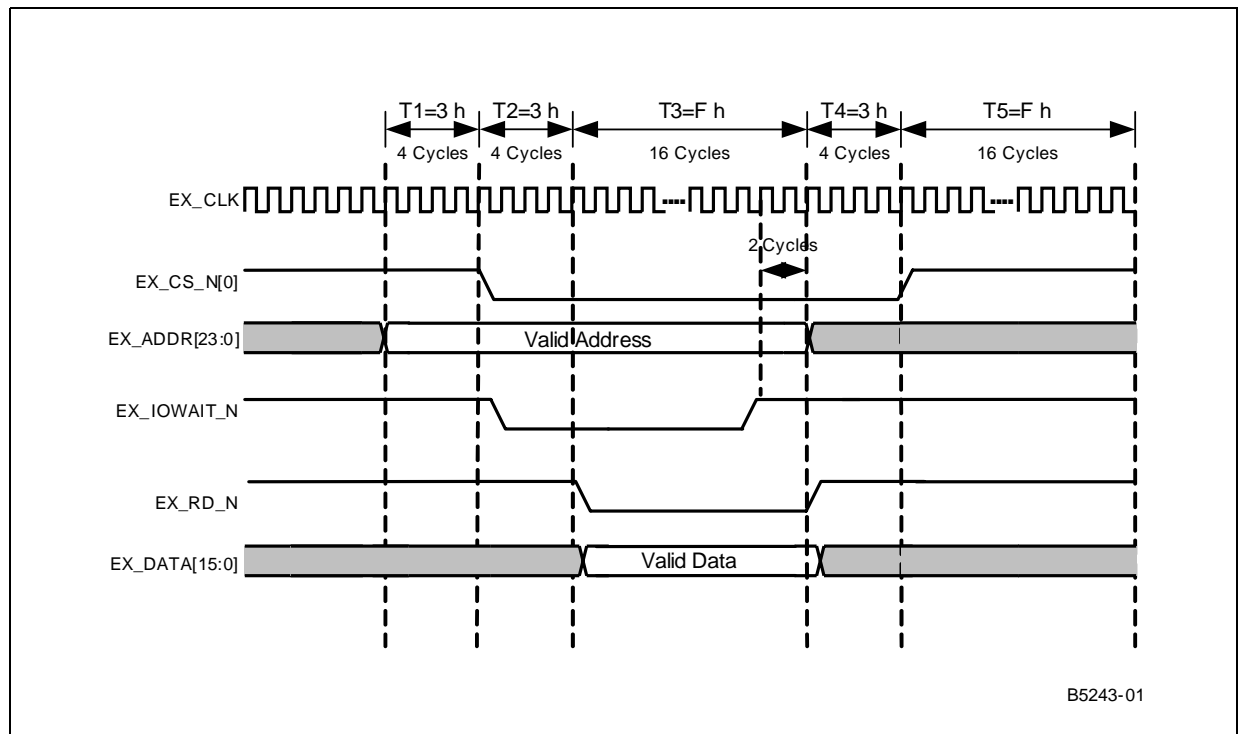



Figure 41. I/O Wait Extended Phase Timing



5.5.2.8 High-Speed, Serial Interfaces

Figure 42. High-Speed, Serial Timings

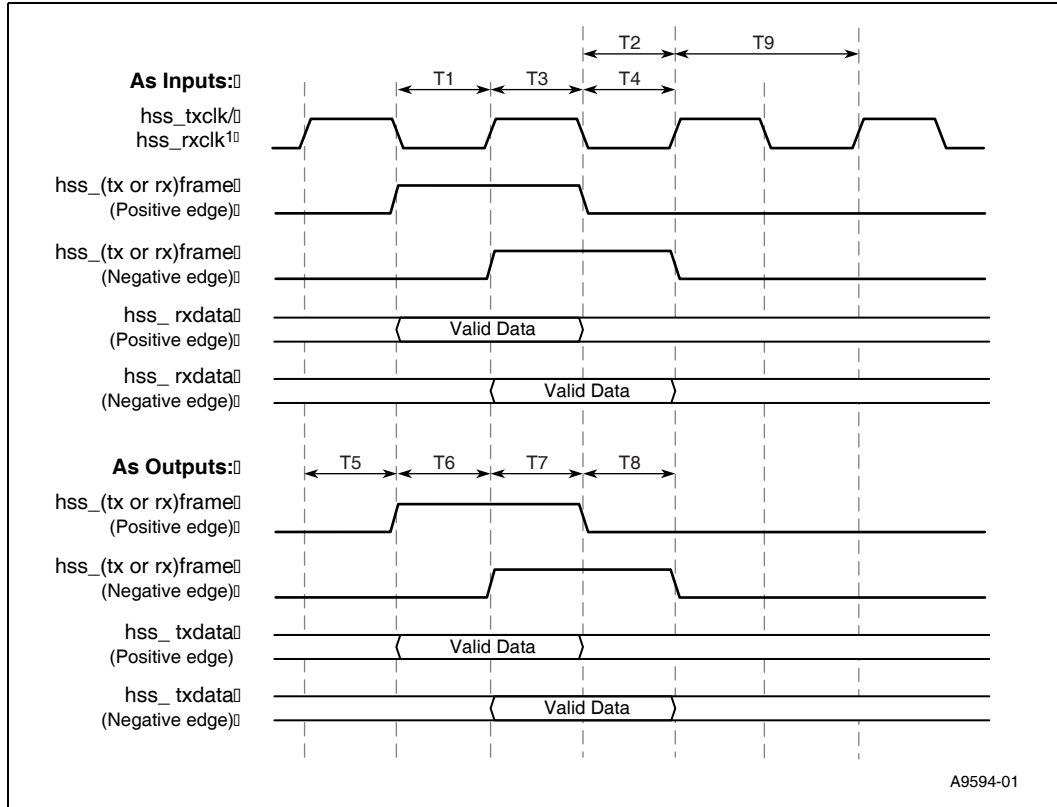



Table 66. High-Speed, Serial Timing Values

Symbol	Parameter	Min.	Max.	Units	Notes
T1	Setup time of HSS_TXFRAME, HSS_RXFRAME, and HSS_RXDATA prior to the rising edge of clock	5		ns	1, 2, 3
T2	Hold time of HSS_TXFRAME, HSS_RXFRAME, and HSS_RXDATA after the rising edge of clock	0		ns	1, 2, 3
T3	Setup time of HSS_TXFRAME, HSS_RXFRAME, and HSS_RXDATA prior to the falling edge of clock	5		ns	1, 2, 3
T4	Hold time of HSS_TXFRAME, HSS_RXFRAME, and HSS_RXDATA after the falling edge of clock	0		ns	1, 2, 3
T5	Rising edge of clock to output delay for HSS_TXFRAME, HSS_RXFRAME, and HSS_TXDATA		15	ns	1, 4
T6	Falling edge of clock to output delay for HSS_TXFRAME, HSS_RXFRAME, and HSS_TXDATA		15	ns	1, 3, 4
T7	Output Hold Delay after rising edge of final clock for HSS_TXFRAME, HSS_RXFRAME, and HSS_TXDATA	0		ns	1, 3, 4
T8	Output Hold Delay after falling edge of final clock for HSS_TXFRAME, HSS_RXFRAME, and HSS_TXDATA	0		ns	1, 3, 4
T9	HSS_TXCLK period and HSS_RXCLK period	1/8.192 MHz	1/512 KHz	ns	5

Notes:

- HSS_TXCLK and HSS_RXCLK may be coming from external independent sources or being driven by the IXP42X product line and IXC1100 control plane processors. The signals are shown to be synchronous for illustrative purposes and are not required to be synchronous.
- Applicable when the HSS_RXFRAME and HSS_TXFRAME signals are being driven by an external source as inputs into the IXP42X product line and IXC1100 control plane processors. Always applicable to HSS_RXDATA.
- The HSS_RXFRAME and HSS_TXFRAME can be configured to accept data on the rising or falling edge of the given reference clock. HSS_RXFRAME and HSS_RXDATA signals are synchronous to HSS_RXCLK and HSS_TXFRAME and HSS_TXDATA signals are synchronous to the HSS_TXCLK.
- Applicable when the HSS_RXFRAME and HSS_TXFRAME signals are being driven by the IXP42X product line and IXC1100 control plane processors to an external source. Always applicable to HSS_TXDATA.
- The HSS_TXCLK can be configured to be driven by an external source or be driven by the IXP42X product line and IXC1100 control plane processors. The slowest clock speed that can be accepted or driven is 512 KHz. The maximum clock speed that can be accepted or driven is 8.192 MHz. The clock duty cycle accepted will be 50/50 + 20%.
- Timing tests were performed with a 70-pF capacitor to ground and a 10-KΩ pull-up resistor.

For more information on the HSS Jitter Specifications see the *Intel® IXP42X Product Line of Network Processors and IXC1100 Control Plane Processor Developer's Manual*.

5.5.2.9 JTAG

Figure 43. Boundary-Scan General Timings

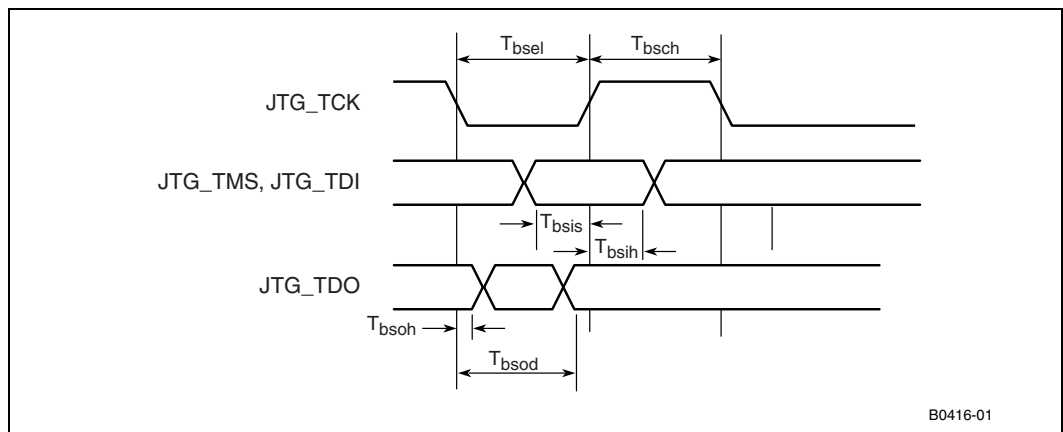

Figure 44. Boundary-Scan Reset Timings

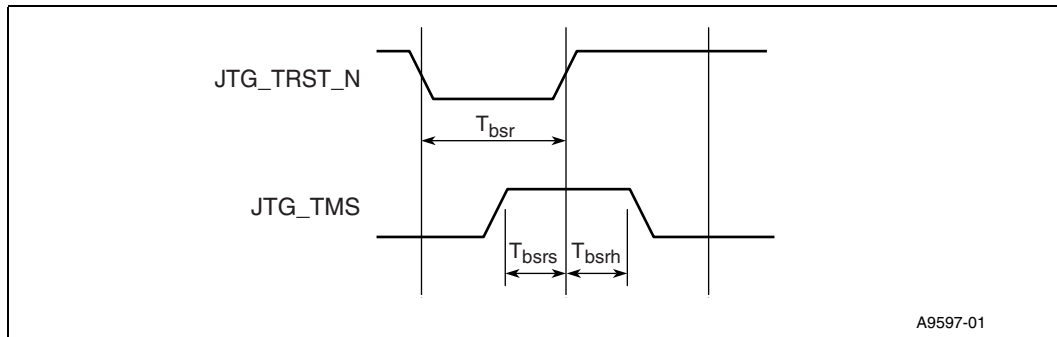

Table 67. Boundary-Scan Interface Timings Values

Symbol	Parameter	Conditions	Min.	Typ.	Max.	Units	Notes
T_{bscl}	JTAG_TCK low time		50			ns	2
T_{bsch}	JTAG_TCK high time		50			ns	2
T_{bsis}	JTAG_TDI, JTAG_TMS setup time to rising edge of JTAG_TCK		10			ns	
T_{bsih}	JTAG_TDI, JTAG_TMS hold time from rising edge of JTAG_TCK		10			ns	
T_{bsoh}	JTAG_TDO hold time after falling edge of JTAG_TCK		1.5			ns	1
T_{bsod}	JTAG_TDO clock to output from falling edge of JTAG_TCK				40	ns	1
T_{bsr}	JTAG_TRST_N reset period		30			ns	
T_{bsrs}	JTAG_TMS setup time to rising edge of JTAG_TRST_N		10			ns	
T_{bsrh}	JTAG_TMS hold time from rising edge of JTAG_TRST_N		10			ns	

Notes:

- Tests completed with a TBD pF load to ground on JTAG_TDO.
- JTAG_TCK may be stopped indefinitely in either the low or high phase.

5.5.3 Reset Timings

The IXP42X product line and IXC1100 control plane processors' can be reset in any of the following three modes:

- Cold Reset
- Warm Reset
- Soft Reset.

Normally, a Cold Reset is executed each time power is initially applied to the board, a Warm Reset is executed when it is only intended to reset the IXP42X product line and IXC1100 control plane processors, and a Soft Reset is executed by the watchdog timer.

5.5.3.1 Cold Reset

A Cold Reset condition is when the network processor is initially powered-up and has successfully come out of the Reset. During this state all internal modules and registers are set to the initial default state. To successfully come out of reset, two things must occur:

- Proper power sequence as described in Section 5.6, "Power Sequence" on page 125



- Followed by proper resetting of PWRON_RST_N and RESET_IN_N signals as described in [Section 5.5.3.4, “Reset Timings” on page 124](#)

The following procedural sequence must be followed to achieve a successful cold reset:

1. VCC and VCC33 power supplies must reach steady state
2. Hold PWRON_RST_N and RESET_IN_N asserted for 2000nSec
3. De-assert PWRON_RST_N (signal goes high with the help of a pull-up resistor)
4. Continue to hold RESET_IN_N asserted for at least 10nSec more after releasing PWRON_RST_N
5. De-assert RESET_IN_N (signal goes high with the help of a pull-up resistor)
6. The network processor asserts PLL_LOCK indicating that the processor has successfully come out of Reset

5.5.3.2 Hardware Warm Reset

A Hardware Warm Reset can only be asserted when PWRON_RST_N is de-asserted and the network processor is in a normal operating mode. A Hardware Warm Reset is initiated by the assertion of RESET_IN_N. During this state, all internal registers and modules are set to their initial default state except for the PLL internal modules. Since the PLL modules are not reset, the Reset sequence is executed much faster by the processor.

The following procedural sequence must be followed to achieve a successful Warm Reset:

1. The system must have previously completed a Cold Reset successfully.
2. PWRON_RST_N must be de-asserted (held high for the entire process).
3. Hold RESET_IN_N asserted for 500nSec.
4. De-assert RESET_IN_N (signal goes high with the help of a pull-up resistor)
5. The network processor asserts PLL_LOCK indicating that the processor has successfully come out of reset.

5.5.3.3 Soft Reset

A Soft Reset condition is accomplished by the usage of the hardware Watch-Dog Timer module, and software to manage and perform counter updates. For a complete description of Watch-Dog Timer functionality, refer to Watchdog Timer sub-section in the Timers Chapter of the *Intel® IXP42X Product Line of Network Processors and IXC1100 Control Plane Processor Developer's Manual*.

The Soft Reset is similar to what is described in [Section 5.5.3.2](#). The main difference is that there is no hardware requirement; everything is done within the network processor and software support. That is why it is also referred to as a Soft Warm Reset. Since Hardware Warm Reset and Soft Reset are very similar, there must be a way to determine which reset was last executed after recovering. This is done by reading the Timer Status Register bit 4 (Warm Reset). If this bit was last set to 1, it will indicate that a Soft Reset was executed, and if the bit was last reset to 0, then it will indicate that the processor has just come out of either a Hardware Warm Reset or a Cold Reset.

5.5.3.4 Reset Timings

Figure 45. Reset Timings

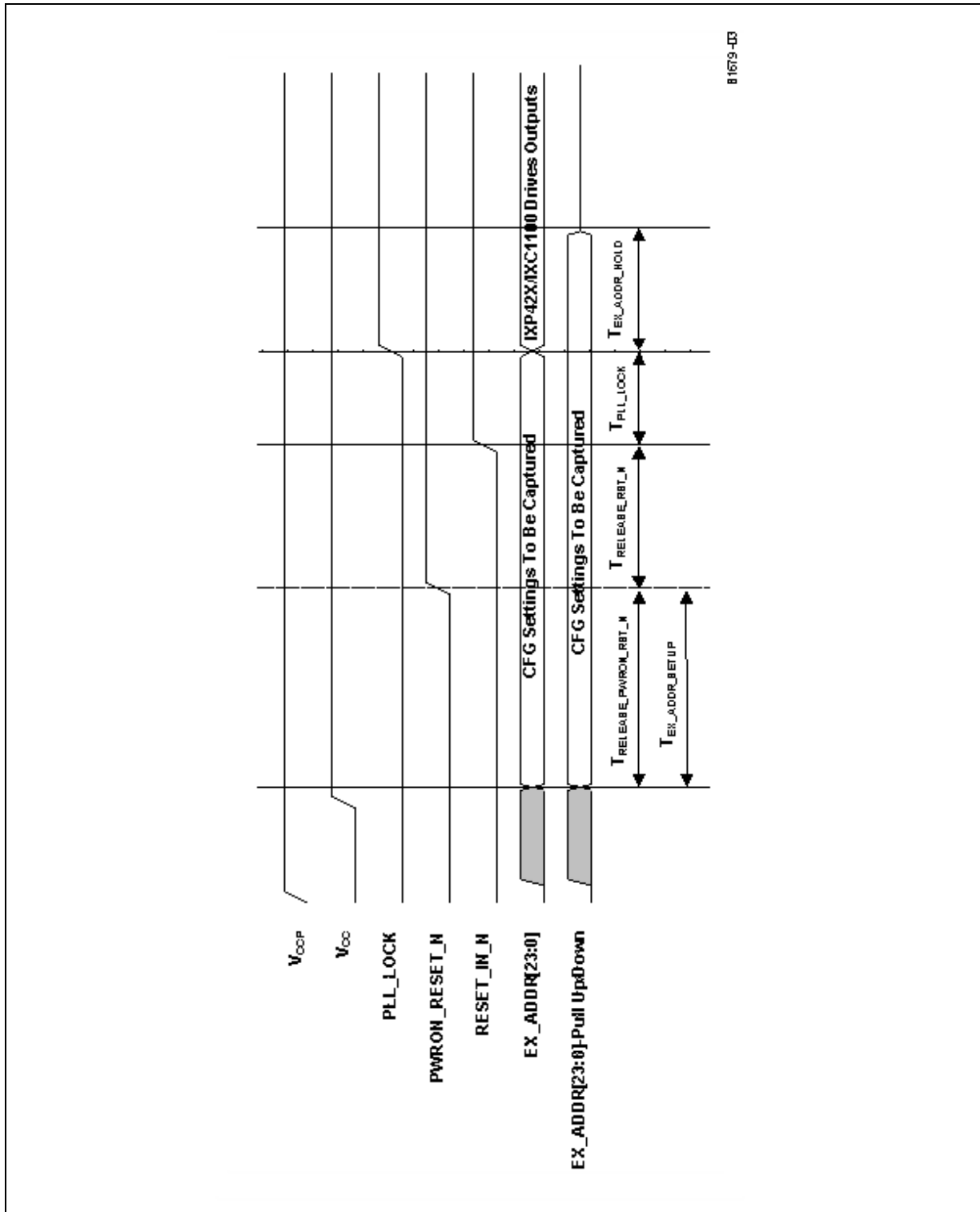



Table 68. Reset Timings Table Parameters

Symbol	Parameter	Min.	Typ.	Max.	Units	Note
$T_{\text{RELEASE_PWRON_RST_N}}$	Minimum time required to hold the PWRON_RST_N at logic 0 state after stable power has been applied to the IXP42X product line and IXC1100 control plane processors.	2000			ns	1
$T_{\text{RELEASE_RESET_IN_N}}$	Minimum time required to hold the RESET_IN_N at logic 0 state after PWRON_RST_N has been released to a logic 1 state. The RESET_IN_N signal must be held low when the PWRON_RST_N signal is held low.	10			ns	
$T_{\text{PLL_LOCK}}$	Maximum time for PLL_LOCK signal to drive to logic 1 after RESET_IN_N is driven to logic 1 state. The boot sequence does not occur until this period is complete.			10	μs	
$T_{\text{EX_ADDR_SETUP}}$	Minimum time for the EX_ADDR signals to drive the inputs prior to RESET_IN_N being driven to logic 1 state. This is used for sampling configuration information.	50			ns	2
$T_{\text{EX_ADDR_HOLD}}$	Minimum/maximum time for the EX_ADDR signals to drive the inputs prior to PLL_LOCK being driven to logic 1 state. This is used for sampling configuration information.	0		20	ns	2
$T_{\text{WARM_RESET}}$	Minimum time required to drive RESET_IN_N signal to logic 0 in order to cause a Warm Reset in the IXP42X product line and IXC1100 control plane processors. During this period, the power supply must not be disturbed and PWRON_RST_N signal must remain at logic high during the entire process.	500			ns	
<p>Notes:</p> <ol style="list-style-type: none"> $T_{\text{RELEASE_PWRON_RST_N}}$ is the time required for the internal oscillator to reach stability. The expansion bus address is captured as a derivative of the RESET_IN_N signal going high. When a programmable-logic device is used to drive the EX_ADDR signals instead of pull-downs, the signals must be active until PLL_LOCK goes high. PLL_LOCK is deasserted immediately when watchdog timer event occurs, or when RESET_IN_N is asserted, or when PWRON_RST_N is asserted. PLL_LOCK remains deasserted for ~ 24 ref_clocks after the watchdog reset is deasserted (internal to the chip). A ref clock time period is 1/CLKIN. 						

5.6 Power Sequence

The 3.3-V I/O voltage (V_{CCP}) must be powered up 1 μs before the Intel XScale® processor voltage (V_{CC}). The IXP42X product line and IXC1100 control plane processors' voltage (V_{CC}) must never become stable prior to the 3.3-V I/O voltage (V_{CCP}). The V_{CCOSC} , V_{CCPLL1} , and V_{CCPLL2} voltages follow the V_{CC} power-up pattern. The V_{CCOSCP} follows the V_{CCP} power-up pattern. The value for $T_{\text{POWER_UP}}$ must be at least 1 μs . The $T_{\text{POWER_UP}}$ timing parameter is measured from V_{CCP} at 3.3 V and V_{CC} at 1.3 V. There are no power-down requirements for the IXP42X product line and IXC1100 control plane processors.

Figure 46. Power-Up Sequence Timing

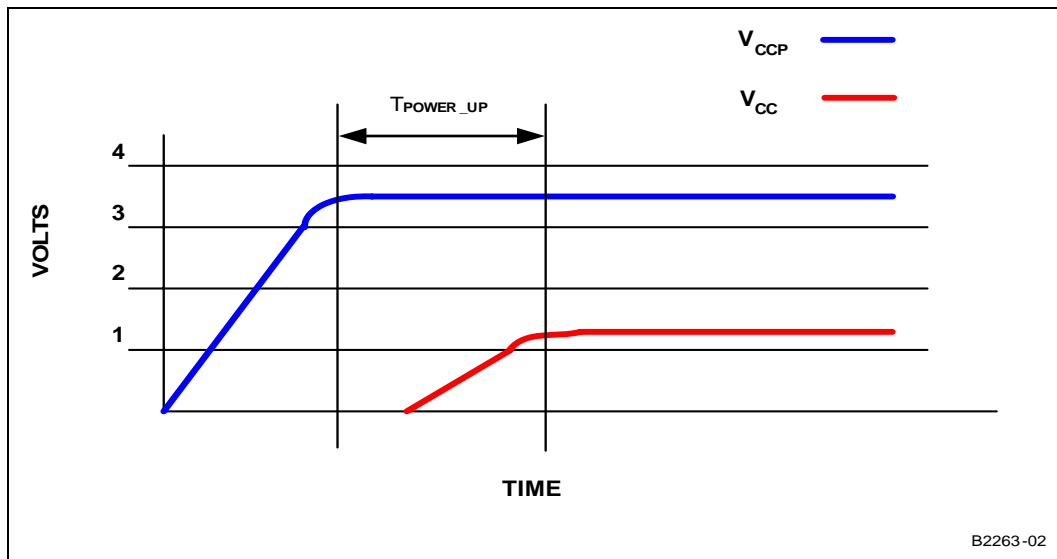

5.7 I_{CC} and Total Average Power

Table 69. I_{CC} and Total Average Power – Commercial Temperature Range (Sheet 1 of 2)

Speed	Symbol	Description	Typical Current and Power ¹	Max Current ²	Average Max Power ²
266 MHz	I_{CC_TOTAL}	Intel XScale® processor supply current	0.70A	0.725A	1.0W
	I_{CCP_TOTAL}	I/O supply current	0.17A	0.26A	0.9W
	P_{TOTAL}	Total average power both supplies	1.5W		1.9W
400 MHz	I_{CC_TOTAL}	Intel XScale® processor supply current	0.75A	0.800A	1.09W
	I_{CCP_TOTAL}	I/O supply current	0.17A	0.26A	0.9W
	P_{TOTAL}	Total average power both supplies	1.57W		2.0W

Notes:

- Typical current I_{CC} and I_{CCP} are not tested. Typical currents were measured on the Intel® IXDP425 / IXCDP1100 Development Platform at room temperature using typical SKU silicon samples. A SmartBits* tester was used in a router application running Linux* on the KIXDP425BD. Two Ethernet NPEs, and two Ethernet controller PCI cards were used in this router application. Typical case power supply voltages $V_{CC} = 1.327V$, $V_{CCP} = 3.363V$. Typical operating temperature is room temperature.
- Maximum voltages: $V_{CC} = 1.365V$, $V_{CCP} = 3.465V$, $V_{CCOSC} = 1.365V$, $V_{CCPLL1} = 1.365V$, $V_{CCPLL2} = 1.365V$, maximum capacitive loading on all I/O pins of 50 pF. Maximum I_{CC} and I_{CCP} are steady state currents at maximum operating temperature.
- I_{CC_TOTAL} includes total current for V_{CC} , V_{CCOSC} , V_{CCPLL1} , and V_{CCPLL2}
- I_{CCP_TOTAL} includes total current for V_{CCP} , V_{CCOSC}



Table 69. I_{CC} and Total Average Power – Commercial Temperature Range (Sheet 2 of 2)

Speed	Symbol	Description	Typical Current and Power ¹	Max Current ²	Average Max Power ²
533 MHz	I _{CC}	Intel XScale® processor supply current	0.82A	1.00A	1.4W
	I _{CCP_TOTAL}	I/O supply current	0.17A	0.26A	0.9W
	P _{TOTAL}	Total average power both supplies	1.66W		2.3W

Notes:

1. Typical current ICC and ICCP are not tested. Typical currents were measured on the Intel® IXDP425 / IXCDP1100 Development Platform at room temperature using typical SKU silicon samples. A SmartBits* tester was used in a router application running Linux* on the KIXDP425BD. Two Ethernet NPEs, and two Ethernet controller PCI cards were used in this router application. Typical case power supply voltages VCC = 1.327V, VCCP = 3.363 V. Typical operating temperature is room temperature.
2. Maximum voltages: VCC = 1.365 V, VCCP = 3.465 V, VCCosc= 1.365 V, VCCPLL1= 1.365 V, VCCPLL2= 1.365 V, maximum capacitive loading on all I/O pins of 50 pF. Maximum ICC and ICCP are steady state currents at maximum operating temperature.
3. I_{CC_TOTAL} includes total current for V_{CC}, V_{CCOSC}, V_{CCPLL1}, and V_{CCPLL2}
4. I_{CCP_TOTAL} includes total current for V_{CCP}, V_{CCOSCP}

Table 70. I_{CC} and Total Average Power – Extended Temperature Range (Sheet 1 of 2)

Speed	Symbol	Description	Typical Current and Power ¹	Max. Current ²	Average Max. Power ²
266 MHz	I _{CC_TOTAL}	Intel XScale® processor supply current	0.70A	0.95A	1.3W
	I _{CCP_TOTAL}	I/O supply current	0.17A	0.26A	0.9W
	P _{TOTAL}	Total average power both supplies	1.5W		2.2W
400 MHz	I _{CC_TOTAL}	Intel XScale® processor supply current	0.75A	1.05A	1.43W
	I _{CCP_TOTAL}	I/O supply current	0.17A	0.26A	0.9W
	P _{TOTAL}	Total average power both supplies	1.57W		2.33W

Notes:

1. Typical current ICC and ICCP are not tested. Typical currents were measured on the Intel® IXDP425 / IXCDP1100 Development Platform at room temperature using typical SKU silicon samples. A SmartBits* tester was used in a router application running Linux on the KIXDP425BD. Two Ethernet NPEs, and two Ethernet controller PCI cards were used in this router application. Typical case power supply voltages VCC = 1.327 V, VCCP = 3.363 V. Typical operating temperature is room temperature.
2. Maximum voltages: VCC = 1.365 V, VCCP = 3.465 V, VCCosc= 1.365 V, VCCPLL1= 1.365 V, VCCPLL2= 1.365 V, maximum capacitive loading on all I/O pins of 50 pF. Maximum ICC and ICCP are steady state currents at maximum operating temperature.
3. I_{CC_TOTAL} includes total current for V_{CC}, V_{CCOSC}, V_{CCPLL1}, and V_{CCPLL2}
4. I_{CCP_TOTAL} includes total current for V_{CCP}, V_{CCOSCP}

Table 70. I_{CC} and Total Average Power – Extended Temperature Range (Sheet 2 of 2)

Speed	Symbol	Description	Typical Current and Power ¹	Max. Current ²	Average Max. Power ²
533 MHz	I _{CC_TOTAL}	Intel XScale® processor supply current	0.82A	1.15A	1.57W
	I _{CCP_TOTAL}	I/O supply current	0.17A	0.26A	0.9W
	P _{TOTAL}	Total average power both supplies	1.66W		2.47W
Notes: 1. Typical current ICC and ICCP are not tested. Typical currents were measured on the Intel® IXDP425 / IXCDP1100 Development Platform at room temperature using typical SKU silicon samples. A SmartBits* tester was used in a router application running Linux on the KIXDP425BD. Two Ethernet NPES, and two Ethernet controller PCI cards were used in this router application. Typical case power supply voltages VCC = 1.327 V, VCCP = 3.363 V. Typical operating temperature is room temperature. 2. Maximum voltages: VCC = 1.365 V, VCCP = 3.465 V, VCCosc = 1.365 V, VCCPLL1 = 1.365 V, VCCPLL2 = 1.365 V, maximum capacitive loading on all I/O pins of 50 pF. Maximum ICC and ICCP are steady state currents at maximum operating temperature. 3. I _{CC_TOTAL} includes total current for V _{CC} , V _{CCOSC} , V _{CCPLL1} , and V _{CCPLL2} 4. I _{CCP_TOTAL} includes total current for V _{CCP} , V _{CCOSCP}					

6.0 Ordering Information

For ordering information, contact your local Intel sales representative.

Refer to [Table 21 on page 48](#) for the part numbers of the Intel® IXP42X Product Line of Network Processors.

