

DS96F173M/DS96F175C/DS96F175M

EIA-485/EIA-422 Quad Differential Receivers

General Description

The DS96F173 and the DS96F175 are high speed quad differential line receivers designed to meet the EIA-485 standard. The DS96F173 and the DS96F175 offer improved performance due to the use of L-FAST bipolar technology. The use of LFAST technology allows the DS96F173 and DS96F175 to operate at higher speeds while minimizing power consumption.

The DS96F173 and the DS96F175 have TRI-STATE® outputs and are optimized for balanced multipoint data bus transmission at rates up to 15 Mbps. The receivers feature high input impedance, input hysteresis for increased noise immunity, and input sensitivity of 200 mV over a common mode input voltage range of -7V to +12V. The receivers are therefore suitable for multipoint applications in noisy environments. The DS96F173 features an active high and active low Enable, common to all four receivers. The DS96F175 features separate active high Enables for each receiver pair.

- Common mode input voltage range: -7V to +12V
- Operates from single +5.0V supply
- Reduced power consumption ($I_{CC} = 50$ mA max)
- Input sensitivity of ± 200 mV over common mode range
- Input hysteresis of 50 mV typical
- High input impedance
- Military temperature range available
- Qualified for MIL STD 883C
- Available to standard military drawings (SMD)
- Available in DIP(J), LCC(E), and FlatPak (W) packages
- DS96F173 and DS96F175 are lead and function compatible with SN75173/175 or the AM26LS32/MC3486

Features

- Meets EIA-485, EIA-422A, EIA-423A standards
- Designed for multipoint bus applications
- TRI-STATE outputs

Logic Diagrams

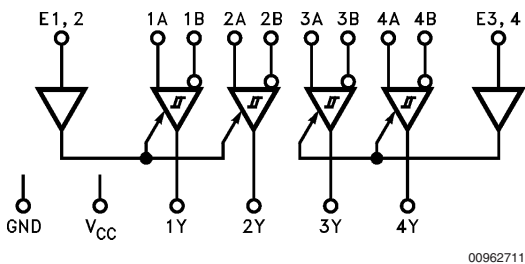
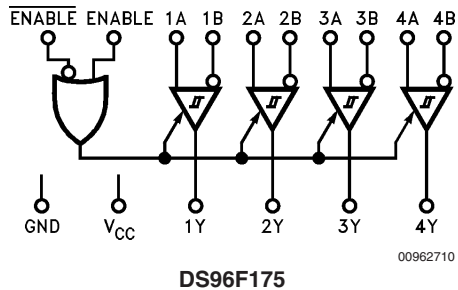

Function Tables

(Each Receiver) DS96F173

Differential Inputs A-B	Enable E \bar{E}		Output Y
$V_{ID} \geq 0.2V$	H	X	H
$V_{ID} \geq 0.2V$	X	L	H
$V_{ID} \leq -0.2V$	H	X	L
$V_{ID} \leq -0.2V$	X	L	L
X	L	X	Z
X	X	H	Z

H = High Level
L = Low Level
Z = High Impedance (off)
X = Don't Care

(Each Receiver) DS96F175

Differential Inputs A-B	Enable E	Output Y
$V_{ID} \geq 0.2V$	H	H
$V_{ID} \leq -0.2V$	H	L
X	L	Z

TRI-STATE® is a registered trademark of National Semiconductor Corporation.

Absolute Maximum Ratings**COMMERCIAL** (Note 2)

Specifications for the 883 version of this product are listed separately.

Storage Temperature Range (T_{STG})	-65°C to +175°C
Lead Temperature (Soldering, 60 sec.)	300°C
Max. Package Power Dissipation (Note 1) at 25°C	
Ceramic DIP (J)	1500 mW
Supply Voltage	7.0V
Input Voltage, A or B Inputs	±25V
Differential Input Voltage	±25V
Enable Input Voltage	7.0V
Low Level Output Current	50 mA

Recommended Operating Conditions

	Min	Typ	Max	Units
Supply Voltage (V_{CC}) DS96F175C	4.75	5.0	5.25	V
Common Mode Input Voltage (V_{CM})	-7		+12	V
Differential Input Voltage (V_{ID})		12		V
Output Current HIGH (I_{OH})			-400	µA
Output Current LOW (I_{OL})			11	mA
Operating Temperature (T_A) DS96F175C	0	25	70	°C

Note 1: Derate package 10 mW/°C above 25°C.

Electrical Characteristics (Notes 3, 4)

Over recommended supply voltage and operating temperature ranges, unless otherwise specified

Symbol	Parameter	Conditions	Min	Typ	Max	Units
V_{TH}	Differential-Input High Threshold Voltage	$V_O = V_{OH}$			0.2	V
V_{TL}	Differential-Input (Note 5) Low Threshold Voltage	$V_O = V_{OL}$	-0.2			V
$V_{TH} - V_{TL}$	Hysteresis (Note 6)	$V_{CM} = 0V$		50		mV
V_{IH}	Enable Input Voltage HIGH		2.0			V
V_{IL}	Enable Input Voltage LOW				0.8	V
V_{IC}	Enable Input Clamp Voltage	$I_I = -18$ mA			-1.5	V
V_{OH}	Output Voltage HIGH	$V_{ID} = 200$ mV	0°C to +70°C	2.8		V
		$I_{OH} = -400$ µA	-55°C to +125°C	2.5		
V_{OL}	Output Voltage LOW	$V_{ID} = -200$ mV	$I_{OL} = 8.0$ mA		0.45	V
			$I_{OL} = 11$ mA		0.50	
I_{OZ}	High-Impedance State Output	$V_O = 0.4V$ to 2.4V			±20	µA
I_I	Line Input Current (Note 7)	Other Input = 0V	$V_I = 12V$		1.0	mA
			$V_I = -7.0V$		-0.8	
I_{IH}	Enable Input Current HIGH	$V_{IH} = 2.7V$			20	µA
I_{IL}	Enable Input Current LOW	$V_{IL} = 0.4V$			-100	µA
R_I	Input Resistance		14	18	22	kΩ
I_{OS}	Short Circuit Output Current	(Note 8)	-15		-85	mA
I_{CC}	Supply Current	No Load	Outputs Enabled		50	mA
			Outputs Disabled		50	

COMMERCIAL**Switching Characteristics** $V_{CC} = 5.0V, T_A = 25^{\circ}C$

Symbol	Parameter	Conditions	Min	Typ	Max	Units
t_{PLH}	Propagation Delay Time, Low to High Level Output	$V_{ID} = -2.5V$ to $+2.5V$, $C_L = 15$ pF, <i>Figure 1</i> $V_{CM} = 0V$	5.0	15	22	ns
t_{PHL}	Propagation Delay Time, High to Low Level Output		5.0	15	22	ns
t_{ZH}	Output Enable Time to High Level	$C_L = 15$ pF, <i>Figure 2</i>		12	16	ns
t_{ZL}	Output Enable Time to Low Level	$C_L = 15$ pF, <i>Figure 3</i>		13	18	ns
t_{HZ}	Output Disable Time from High Level	$C_L = 5.0$ pF, <i>Figure 2</i>		14	20	ns
t_{LZ}	Output Disable Time from Low Level	$C_L = 5.0$ pF, <i>Figure 3</i>		14	18	ns
$ t_{PLH} - t_{PHL} $	Pulse Width Distortion (SKEW)	<i>Figure 1</i>		1.0	3.0	ns

Note 2: "Absolute Maximum Ratings" are those values beyond which the safety of the device cannot be guaranteed. They are not meant to imply that the devices should be operated at these limits. The tables of "Electrical Characteristics" provide conditions for actual device operation.

Note 3: Unless otherwise specified min/max limits apply across the $0^{\circ}C$ to $+70^{\circ}C$ range for the DS96F175C. All typicals are given for $V_{CC} = 5V$ and $T_A = 25^{\circ}C$.

Note 4: All currents into the device pins are positive; all currents out of the device pins are negative. All voltages are reference to ground unless otherwise specified.

Note 5: The algebraic convention, when the less positive (more negative) limit is designated minimum, is used in this data sheet for common mode input voltage and threshold voltage levels only.

Note 6: Hysteresis is the difference between the positive-going input threshold voltage, V_{TH} , and the negative going input threshold voltage, V_{TL} .

Note 7: Refer to EIA-485 Standard for exact conditions.

Note 8: Only one output at a time should be shorted.

Order Number: DS96F175CJ

See NS Package Number J16A

MIL-STD-883C

Absolute Maximum Ratings (Note 2)

For complete Military Specifications, refer to the appropriate SMD or MDS.

Storage Temperature Range (T _{STG})	-65°C to +175°C
Lead Temperature (Soldering, 60 sec.)	300°C
Max. Package Power Dissipation (Note 9) at 25°C	

Ceramic DIP (J)	1500 mW
Ceramic Flatpak (W)	1034 mW
Ceramic LCC (E)	1500 mW
Supply Voltage	7.0V
Input Voltage, A or B Inputs	±25V
Differential Input Voltage	±25V
Enable Input Voltage	7.0V
Low Level Output Current	50 mA

Recommended Operating Conditions

	Min	Typ	Max	Units		Min	Typ	Max	Units
Supply Voltage (V _{CC})					Output Current LOW (I _{OL})			11	mA
DS96F173M/DS96F175M	4.50	5.0	5.50	V	Operating Temperature (T _A)				
Common Mode					DS96F173M/DS96F175M	-55	25	125	°C
Input Voltage (V _{CM})	-7		+12	V	Note 9: Above T _A = 25°C derate J package 10 mW/°C, W package 6.90 mW/°C, E package 11.11 mW/°C.				
Differential Input Voltage (V _{ID})			12	V					
Output Current HIGH (I _{OH})			-400	µA					

Electrical Characteristics (Notes 3, 4)

Over recommended supply voltage and operating temperature ranges, unless otherwise specified

Symbol	Parameter	Conditions	Min	Max	Units
V _{TH}	Differential-Input High Threshold Voltage	V _{CC} = 4.5V, 5.5V V _{CM} = 0V, 12V, -12V		0.2	V
V _{TL}	Differential-Input (Note 5) Low Threshold Voltage	V _{CC} = 4.5V, 5.5V V _{CM} = 0V, 12V, -12V	-0.2		V
V _{IH}	Enable Input Voltage HIGH		2.0		V
V _{IL}	Enable Input Voltage LOW			0.8	V
V _{IC}	Enable Input Clamp Voltage	I _I = -18 mA, V _{CC} = 4.5V		-1.5	V
V _{OH}	Output Voltage HIGH	V _{ID} = 200 mV I _{OH} = -400 µA -55°C to +125°C	2.5		V
V _{OL}	Output Voltage LOW	V _{ID} = -200 mV I _{OL} = 8.0 mA		0.45	V
I _{OZ}	High-Impedance State Output	V _O = 0.4V, 2.4V, V _{CC} = 5.5V		±20	µA
I _I	Line Input Current (Note 7)	Other Input = 0V V _I = 12V V _I = -7.0V		1.0 -0.8	mA
I _{IH}	Enable Input Current HIGH	V _{IH} = 2.7V, V _{CC} = 5.5V		20	µA
I _{IL}	Enable Input Current LOW	V _{IL} = 0.4V, V _{CC} = 5.5V		-100	µA
R _I	Input Resistance		10		kΩ
I _{OS}	Short Circuit Output Current	(Note 8)	-15	-85	mA
I _{CC}	Supply Current	No Load		50	mA
I _{CCX}		Outputs Enabled or Disabled			

MIL-STD-883C

Switching Characteristics

V_{CC} = 5.0V

Symbol	Parameter	Conditions	T _A = 25°C		T _A = -55°C	T _A = 125°C	Units
			Typ	Max	Max	Max	
t _{PLH}	Propagation Delay Time, Low to High Level Output	V _{ID} = -2.5V to +2.5V, C _L = 15 pF, Figure 1	15	22	30	30	ns
t _{PHL}	Propagation Delay Time,	V _{CM} = 0V	15	22	30	30	ns

MIL-STD-883C (Continued)

Switching Characteristics (Continued)

V_{CC} = 5.0V

Symbol	Parameter	Conditions	T _A = 25°C		T _A = -55°C	T _A = 125°C	Units
			Typ	Max	Max	Max	
	High to Low Level Output						
t _{ZH}	Output Enable Time to High Level	C _L = 15 pF, <i>Figure 2</i>	12	16	27	27	ns
t _{ZL}	Output Enable Time to Low Level	C _L = 15 pF, <i>Figure 3</i>	13	18	27	27	ns
t _{HZ}	Output Disable Time from High Level	C _L = 5.0 pF, <i>Figure 2</i> (Note 15)	14	20	27	27	ns
		C _L = 20 pF, <i>Figure 2</i> (Note 15)	14	30	37	37	ns
t _{LZ}	Output Disable Time from Low Level	C _L = 5.0 pF, <i>Figure 3</i>	14	18	30	30	ns
t _{PLH} - t _{PHL}	Pulse Width Distortion (SKEW)	<i>Figure 1</i>	1	3	5.0	5.0	ns

SMD Number:	DS96F173MJ	5962-9076602 MEA
	DS96F173MW	5962-9076602 MFA
	DS96F173ME	5962-9076602 M2A
	DS96F175MJ	5962-9076601 MEA
	DS96F175MW	5962-9076601 MFA
	DS96F175ME	5962-9076601 M2A

Order Number:	883 Marking	SMD Marking
	DS96F173MJ/883	DS96F173MJ-SMD
	DS96F175MJ/883	DS96F175MJ-SMD
	See NS Package Number J16A	
	DS96F173ME/883	DS96F173ME-SMD
	DS96F175ME/883	DS96F175ME-SMD
	See NS Package Number E20A	
	DS96F173MW/883	DS96F173MW-SMD
	DS96F175MW/883	DS96F175MW-SMD
	See NS Package Number W16A	

For complete Military Product Specifications, refer to the appropriate SMD or MDS.

Connection Diagrams

16-Lead Ceramic Dual-In-Line Package
NS Package Number J16A

DS96F173

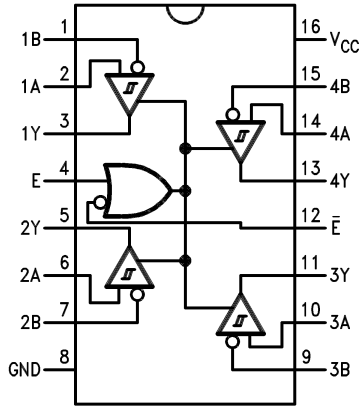

00962701

Top View

DS96F175

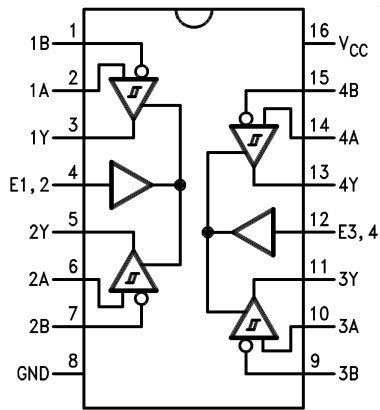

00962702

Top View

16-Lead Ceramic Flatpak
NS Package Number W16A

20-Lead Ceramic Leadless Chip Carrier
NS Package Number E20A

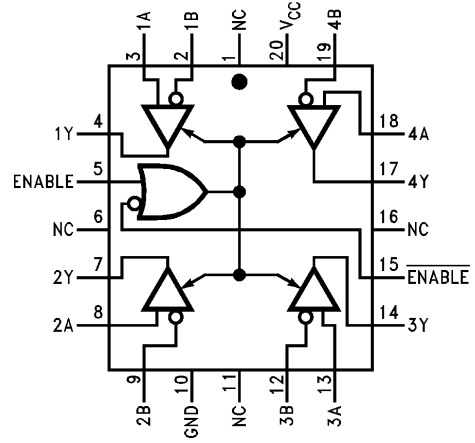

00962712

Top View

*NC—No Connection

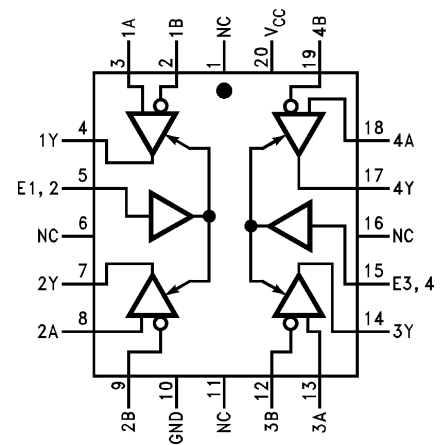

00962713

Top View

Connection Diagrams (Continued)

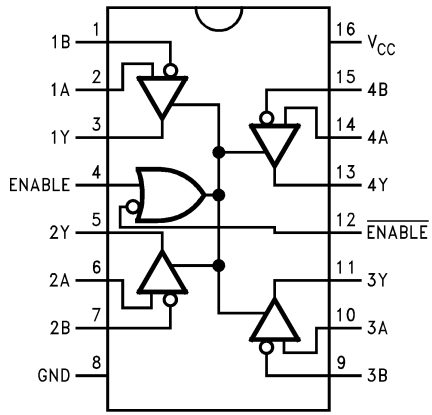

Top View

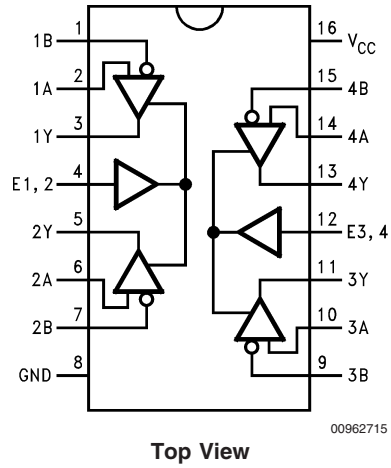

Top View

Order Numbers are located at the end of the respective Electrical Tables.

Parameter Measurement Information

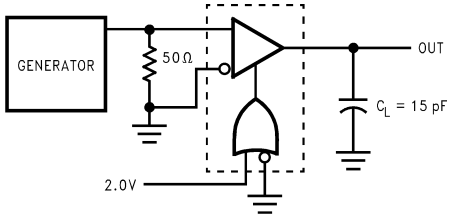

00962703

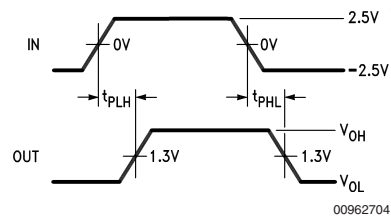

00962704

FIGURE 1. t_{PLH} , t_{PHL} (Notes 10, 11)

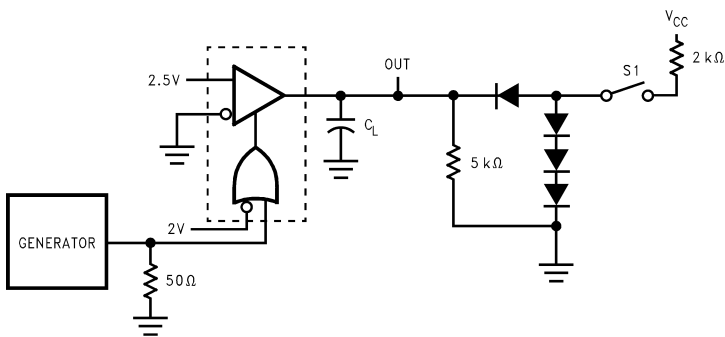

00962705

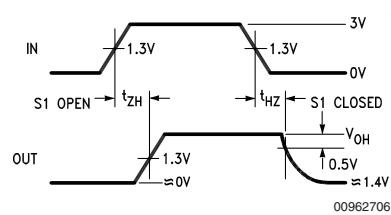

00962706

FIGURE 2. t_{HZ} , t_{ZH} (Notes 10, 11, 13, 14)

Parameter Measurement Information (Continued)

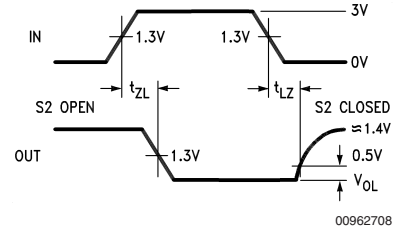
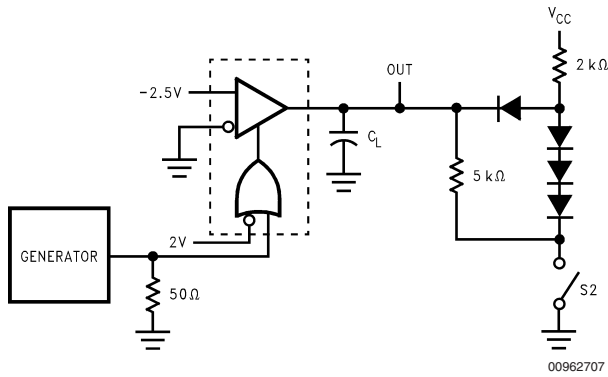

FIGURE 3. t_{ZL} , t_{LZ} (Notes 10, 11, 13, 14)

Note 10: The input pulse is supplied by a generator having the following characteristics: $f = 1.0$ MHz, 50% duty cycle, $t_r \leq 6.0$ ns, $t_f \leq 6.0$ ns, $Z_O = 50\Omega$.

Note 11: C_L includes probe and stray capacitance.

Note 12: DS96F173 with active high and active low Enables are shown. DS96F175 has active high Enable only.

Note 13: All diodes are 1N916 or equivalent.

Note 14: To test the active low Enable \bar{E} of DS96F173, ground E and apply an inverted input waveform to \bar{E} . DS96F175 has active high enable only.

Note 15: Testing at 20 pF assures conformance to 5 pF specification.

Typical Application

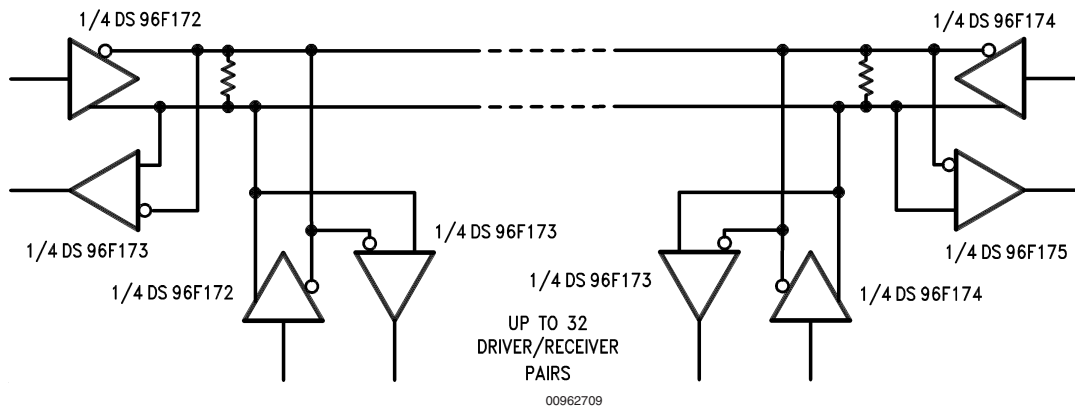
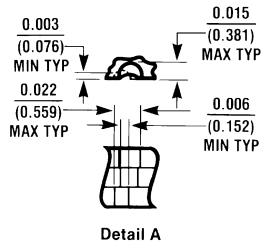
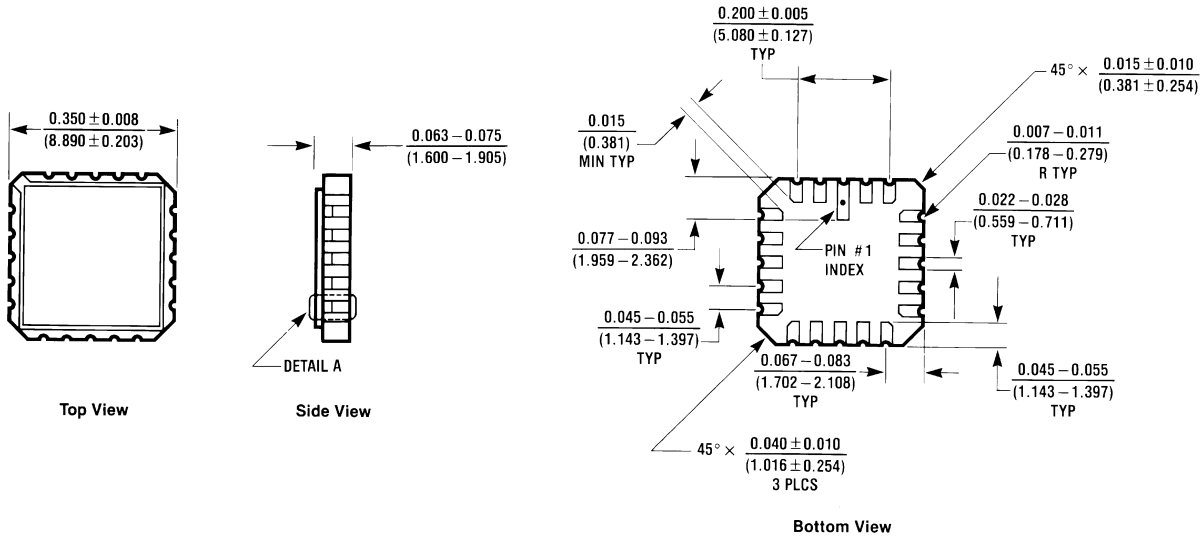

FIGURE 4.

Note: The line length should be terminated at both ends in its characteristic impedance. Stub lengths off the main line should be kept as short as possible.

Physical Dimensions inches (millimeters)

unless otherwise noted



E20A (REV D)

20-Lead Ceramic Leadless Chip Carrier (E)
 Order Number DS96F173ME/883 or DS96F175ME/883
 NS Package Number E20A

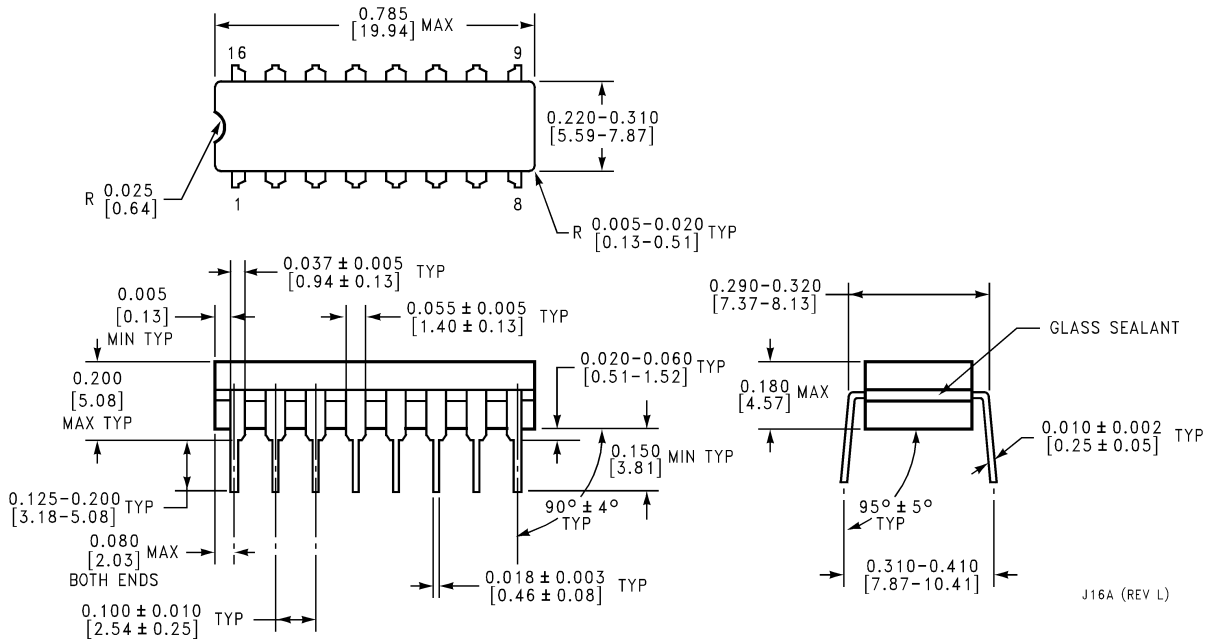

J16A (REV L)

16-Lead Ceramic Dual-In-Line Package (J)
 Order Number DS96F175CJ, DS96F173MJ/883 or DS96F175MJ/883
 NS Package Number J16A

Physical Dimensions inches (millimeters) unless otherwise noted (Continued)

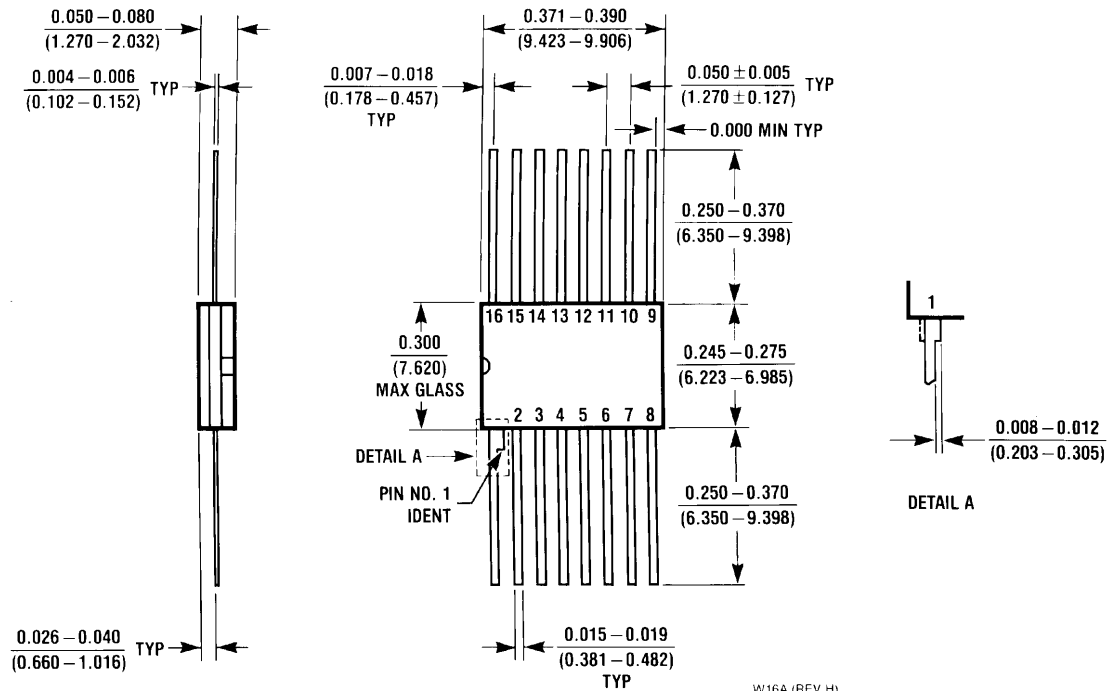

16-Lead Ceramic FlatPak (W)
Order Number DS96F173MW/883 or DS96F175MW/883
NS Package Number W16A

National does not assume any responsibility for use of any circuitry described, no circuit patent licenses are implied and National reserves the right at any time without notice to change said circuitry and specifications.

For the most current product information visit us at www.national.com.

LIFE SUPPORT POLICY

NATIONAL'S PRODUCTS ARE NOT AUTHORIZED FOR USE AS CRITICAL COMPONENTS IN LIFE SUPPORT DEVICES OR SYSTEMS WITHOUT THE EXPRESS WRITTEN APPROVAL OF THE PRESIDENT AND GENERAL COUNSEL OF NATIONAL SEMICONDUCTOR CORPORATION. As used herein:

1. Life support devices or systems are devices or systems which, (a) are intended for surgical implant into the body, or (b) support or sustain life, and whose failure to perform when properly used in accordance with instructions for use provided in the labeling, can be reasonably expected to result in a significant injury to the user.
2. A critical component is any component of a life support device or system whose failure to perform can be reasonably expected to cause the failure of the life support device or system, or to affect its safety or effectiveness.

BANNED SUBSTANCE COMPLIANCE

National Semiconductor certifies that the products and packing materials meet the provisions of the Customer Products Stewardship Specification (CSP-9-111C2) and the Banned Substances and Materials of Interest Specification (CSP-9-111S2) and contain no "Banned Substances" as defined in CSP-9-111S2.

 **National Semiconductor**
Americas Customer Support Center
 Email: new.feedback@nsc.com
 Tel: 1-800-272-9959

National Semiconductor
Europe Customer Support Center
 Fax: +49 (0) 180-530 85 86
 Email: europa.support@nsc.com
 Deutsch Tel: +49 (0) 69 9508 6208
 English Tel: +44 (0) 870 24 0 2171
 Français Tel: +33 (0) 1 41 91 8790

National Semiconductor
Asia Pacific Customer Support Center
 Email: ap.support@nsc.com

National Semiconductor
Japan Customer Support Center
 Fax: 81-3-5639-7507
 Email: jpn.feedback@nsc.com
 Tel: 81-3-5639-7560

www.national.com