

**Features**

September 2005

- Complete DTMF transmitter/receiver
- Low voltage operation (2.7-3.6 V)
- Pin for pin compatible with existing MT8880, MT8888 and MT8889 devices
- Adaptive micro interface enables compatibility with Intel and Motorola processors
- DTMF transmitter/receiver power-down via register control
- Adjustable guard time
- Automatic tone burst mode
- Call progress tone detection to -30 dBm

**Applications**

- Credit card systems
- Paging systems
- Repeater systems/mobile radio
- Interconnect dialers
- Pay phones
- Remote monitor/Control systems

**Description**

The MT88L89 is a monolithic DTMF transceiver with call progress filter. It is fabricated in CMOS technology offering low power consumption and high reliability.

**Ordering Information**

MT88L89AE	20 Pin PDIP	Tubes
MT88L89AN	24 Pin SSOP	Tubes
MT88L89AP	28 Pin PLCC	Tubes
MT88L89AS	20 Pin SOIC	Tubes
MT88L89ANR1	24 Pin SSOP*	Tubes
MT88L89AS1	20 Pin SOIC*	Tubes
MT88L89ANR	24 Pin SSOP	Tape & Reel
MT88L89ASR	20 Pin SOIC	Tape & Reel
MT88L89ASR1	20 Pin SOIC*	Tape & Reel

\*Pb Free Matte Tin

-40°C to +85°C

The receiver section is based upon the industry standard MT8870 DTMF receiver. The transmitter utilizes a switched capacitor D/A converter for low distortion, high accuracy DTMF signalling. Internal counters provide a burst mode such that tone bursts can be transmitted with precise timing. A call progress filter can be selected allowing a microprocessor to analyze call progress tones.

The MT88L89 utilizes an adaptive micro interface, which allows the device to be connected to a number of popular microcontrollers with minimal external logic. The MT88L89 provides enhanced power-down features. The transmitter and receiver may independently be powered down via register control.

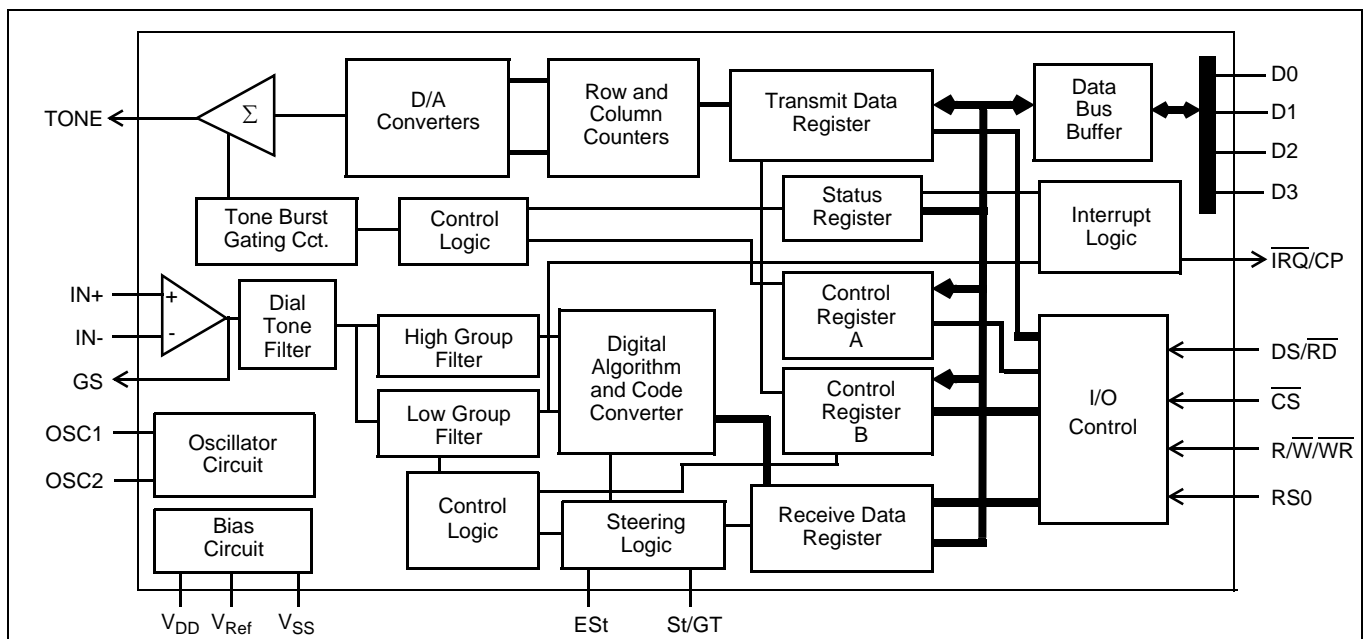
**Figure 1 - Functional Block Diagram**

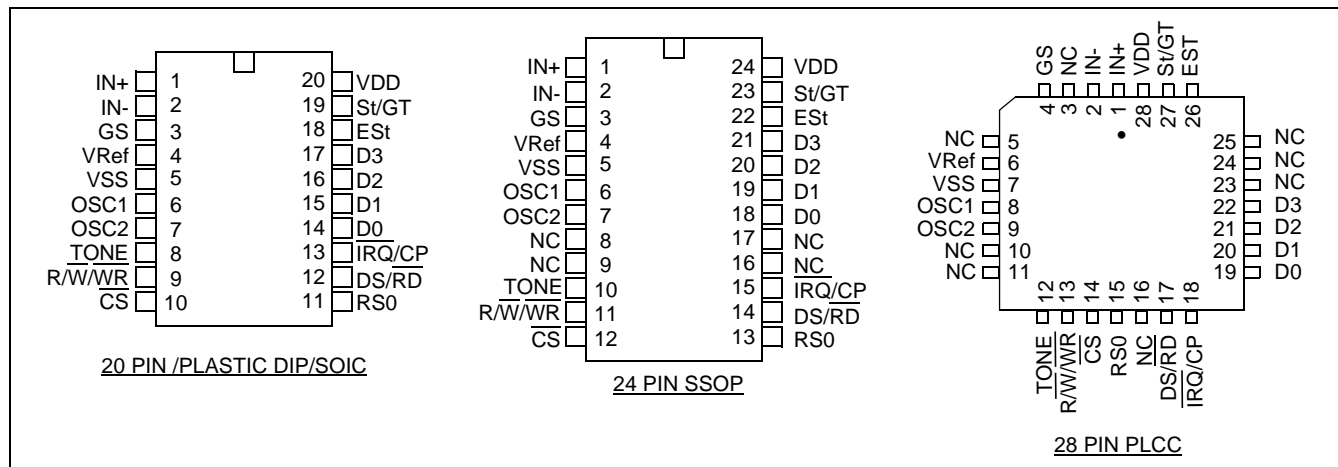

Figure 2 - Pin Connections

Pin Description

Pin #			Name	Description
20	24	28		
1	1	1	IN+	<b>Non-inverting</b> op-amp input.
2	2	2	IN-	<b>Inverting</b> op-amp input.
3	3	4	GS	<b>Gain Select.</b> Gives access to output of front end differential amplifier for connection of feedback resistor.
4	4	6	V <sub>Ref</sub>	<b>Reference Voltage</b> output (V <sub>DD</sub> /2).
5	5	7	V <sub>SS</sub>	Ground (0 V).
6	6	8	OSC1	<b>Oscillator</b> input. This pin can also be driven directly by an external clock. CMOS compatible.
7	7	9	OSC2	<b>Oscillator</b> output. A 3.579545 MHz crystal connected between OSC1 and OSC2 completes the internal oscillator circuit. Leave open circuit when OSC1 is driven externally.
8	10	12	TONE	Output from internal DTMF transmitter. High impedance when TOUT bit in Control Register A (CRA) is set to low. Requires resistive termination to V <sub>SS</sub> .
9	11	13	R/W (WR)	(Motorola) <b>Read/Write</b> or (Intel) <b>Write</b> microprocessor input. CMOS compatible.
10	12	14	CS	<b>Chip Select</b> input must be gated externally by either address strobe (AS), valid memory address (VMA) or address latch enable (ALE) signal, depending on processor used. See Figure 12. Must not be tied low. CMOS compatible.
11	13	15	RS0	<b>Register Select</b> input. Refer to Table 3 for bit interpretation. CMOS compatible.
12	14	17	DS (RD)	(Motorola) <b>Data Strobe</b> or (Intel) <b>Read</b> microprocessor input. Activity on this input is only required when the device is being accessed. CMOS compatible.
13	15	18	IRQ/CP	<b>Interrupt Request/Call Progress</b> (open drain) output. In interrupt mode, this output goes low when a valid DTMF tone burst has been transmitted or received. In call progress mode, this pin will output a rectangular signal representative of the input signal applied at the input op-amp. The input signal must be within the bandwidth limits of the call progress filter. See Figure 10.

## Pin Description

Pin #			Name	Description
20	24	28		
14-17	18-21	19-22	D0-D3	Microprocessor data bus. High impedance when $\overline{CS} = 1$ or $DS = 0$ (Motorola) or $RD = 1$ (Intel). CMOS compatible.
18	22	26	ES <sub>t</sub>	<b>Early Steering</b> output. Presents a logic high once the digital algorithm has detected a valid tone pair (signal condition). Any momentary loss of signal condition will cause ES <sub>t</sub> to return to a logic low.
19	23	27	St/GT	<b>Steering Input/Guard Time</b> output (bidirectional). A voltage greater than $V_{TSt}$ detected at St causes the device to register the detected tone pair and update the output latch. A voltage less than $V_{TSt}$ frees the device to accept a new tone pair. The GT output acts to reset the external steering time-constant; its state is a function of ES <sub>t</sub> and the voltage on St.
20	24	28	V <sub>DD</sub>	Positive power supply (3 V typ.).
	8, 9 16, 17	3, 5, 10-11 16 23-25	NC	No Connection.

## Functional Description

The MT88L89 Integrated DTMF Transceiver consists of a high performance DTMF receiver with an internal gain setting amplifier and a DTMF generator, which employs a burst counter to synthesize precise tone bursts and pauses. A call progress mode can be selected so that frequencies within the specified passband can be detected. The adaptive micro interface allows various microcontrollers to access the MT88L89 internal registers.

## Power-Down

The MT88L89 provides enhanced power-down functionality to facilitate minimization of supply current consumption. DTMF transmitter and receiver circuit blocks can be independently powered down via register control. When asserted, RxEN control bit powers down all analog and digital circuitry associated solely with the DTMF and Call Progress receiver. The TOUT control bit is used to disable the transmitter and put all circuitry associated only with the DTMF transmitter in power-down mode. With the TOUT control bit is set to zero, the TONE output pin is held in a high impedance (floating) state. When both transmitter and receiver circuits are powered down, circuits utilized by both the DTMF transmitter and receiver are also powered down. This power-down control disables the crystal oscillator, and the  $V_{Ref}$  generator. In addition, the IRQ, TONE output and DATA pins are held in a high impedance state.

## Input Configuration

The input arrangement of the MT88L89 provides a differential-input operational amplifier as well as a bias source ( $V_{Ref}$ ), which is used to bias the inputs at  $V_{DD}/2$ . Provision is made for connection of a feedback resistor to the op-amp output (GS) for gain adjustment.

For applications which are required to meet a guaranteed RX input level of -29 dBm over the full temperature and supply voltage range, a unity gain input configuration as shown in Figures 3 and 4 can be used.

For applications which require signal detection lower than -29 dBm, the external resistors can be configured to give adequate gain. For example, if the application requires tone detection of -31 dBm, the input gain can be set to +2 dB with the external resistors (see Figures 13 and 14 for value of resistors). However, when +2 dB gain is used, the corresponding maximum input signal level must not exceed -6 dBm.

**Receiver Section**

Separation of the low and high group tones is achieved by applying the DTMF signal to the inputs of two sixth-order switched capacitor bandpass filters, the bandwidths of which correspond to the low and high group frequencies (see Table 1). The filters also incorporate notches at 350 Hz and 440 Hz for exceptional dial tone rejection. Each filter output is followed by a single order switched capacitor filter section, which smooths the signals prior to limiting. Limiting is performed by high-gain comparators which are provided with hysteresis to prevent detection of unwanted low-level signals. The outputs of the comparators provide full rail logic swings at the frequencies of the incoming DTMF signals.

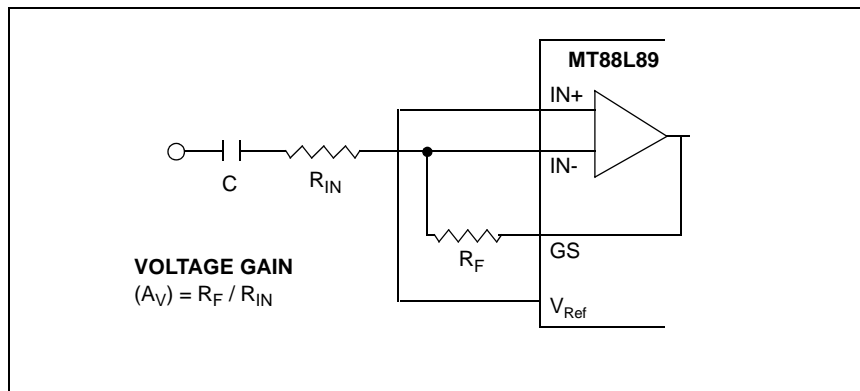

**Figure 3 - Single-Ended Input Configuration**

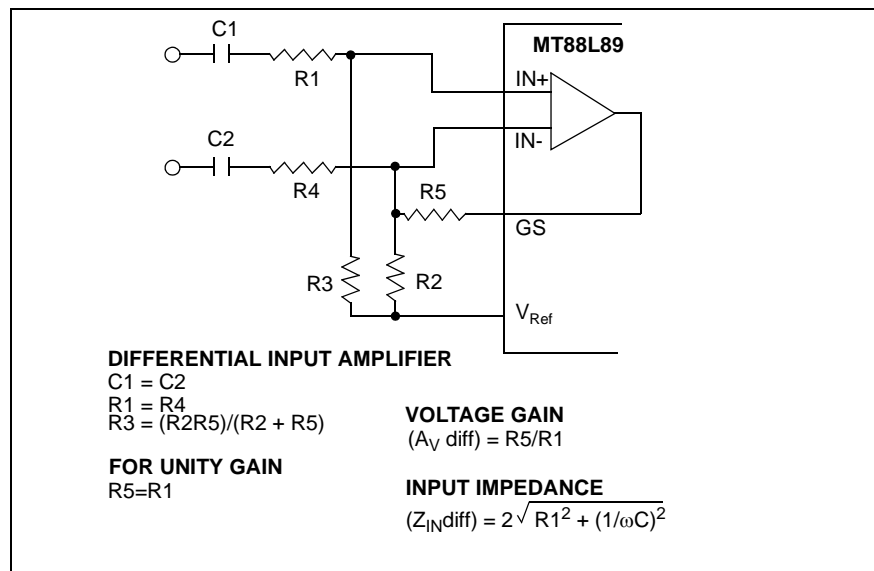

**Figure 4 - Differential Input Configuration**

F <sub>LOW</sub>	F <sub>HIGH</sub>	DIGIT	D <sub>3</sub>	D <sub>2</sub>	D <sub>1</sub>	D <sub>0</sub>
697	1209	1	0	0	0	1
697	1336	2	0	0	1	0
697	1477	3	0	0	1	1
770	1209	4	0	1	0	0
770	1336	5	0	1	0	1
770	1477	6	0	1	1	0
852	1209	7	0	1	1	1
852	1336	8	1	0	0	0
852	1477	9	1	0	0	1
941	1336	0	1	0	1	0
941	1209	*	1	0	1	1
941	1477	#	1	1	0	0
697	1633	A	1	1	0	1
770	1633	B	1	1	1	0
852	1633	C	1	1	1	1
941	1633	D	0	0	0	0

0= LOGIC LOW, 1= LOGIC HIGH

**Table 1 - Functional Encode/Decode Table**

Following the filter section is a decoder employing digital counting techniques to determine the frequencies of the incoming tones and to verify that they correspond to standard DTMF frequencies. A complex averaging algorithm protects against tone simulation by extraneous signals such as voice while providing tolerance to small frequency deviations and variations. This averaging algorithm has been developed to ensure an optimum combination of immunity to talk-off and tolerance to the presence of interfering frequencies (third tones) and noise. When the detector recognizes the presence of two valid tones (this is referred to as the “signal condition” in some industry specifications) the “Early Steering” (ESt) output will go to an active state. Any subsequent loss of signal condition will cause ESt to assume an inactive state.

### Steering Circuit

Before registration of a decoded tone pair, the receiver checks for a valid signal duration (referred to as character recognition condition). This check is performed by an external RC time constant driven by ESt. A logic high on ESt causes  $v_c$  (see Figure 5) to rise as the capacitor discharges. Provided that the signal condition is maintained (ESt remains high) for the validation period ( $t_{GTP}$ ),  $v_c$  reaches the threshold ( $V_{TSt}$ ) of the steering logic to register the tone pair, latching its corresponding 4-bit code (see Table 1) into the Receive Data Register. At this point the GT output is activated and drives  $v_c$  to  $V_{DD}$ . GT continues to drive high as long as ESt remains high. Finally, after a short delay to allow the output latch to settle, the delayed steering output flag goes high, signalling that a received tone pair has been registered. The status of the delayed steering flag can be monitored by checking the appropriate bit in the status register. If Interrupt mode has been selected, the IRQ/CP pin will pull low when the delayed steering flag is active.

The contents of the output latch are updated on an active delayed steering transition. This data is presented to the four bit bidirectional data bus when the Receive Data Register is read. The steering circuit works in reverse to validate the interdigit pause between signals. Thus, as well as rejecting signals too short to be considered valid, the receiver will tolerate signal interruptions (drop out) too short to be considered a valid pause. This facility, together with the capability of selecting the steering time constants externally, allows the designer to tailor performance to meet a wide variety of system requirements.

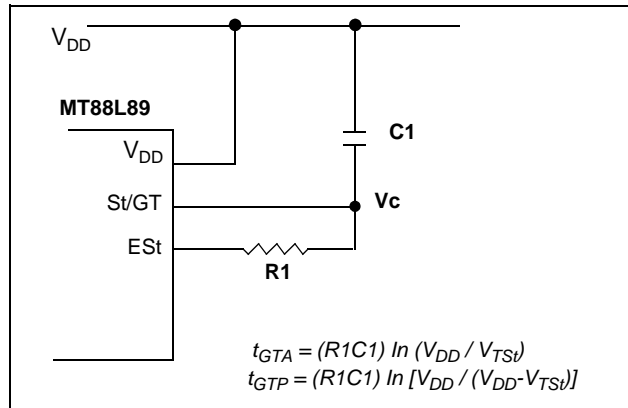

Figure 5 - Basic Steering Circuit

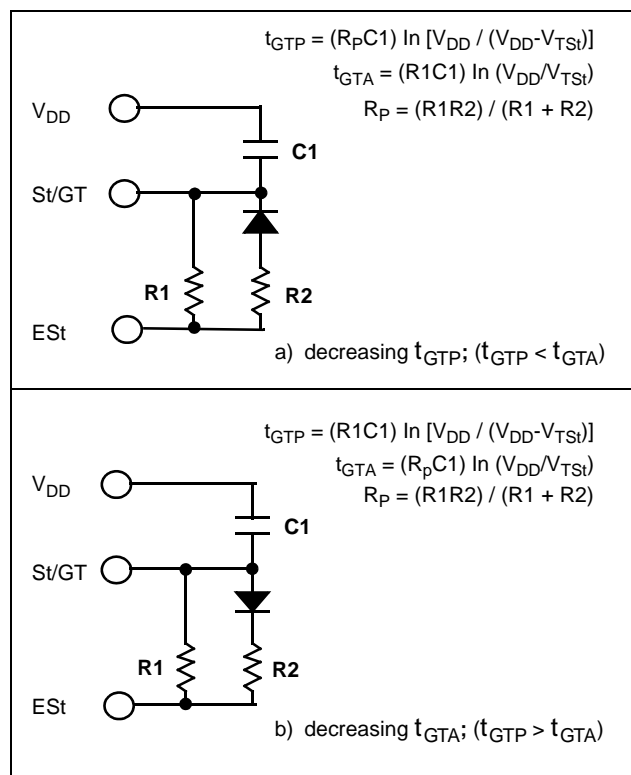

Figure 6 - Guard Time Adjustment

**Guard Time Adjustment**

The simple steering circuit shown in Figure 5 is adequate for most applications. Component values are chosen according to the following inequalities (see Figure 7):

$$\begin{aligned}
 t_{REC} &\geq t_{DPmax} + t_{GTPmax} - t_{DAmin} \\
 t_{REC} &\leq t_{DPmin} + t_{GTPmin} - t_{DAmax} \\
 t_{ID} &\geq t_{DAmax} + t_{GTAmx} - t_{DPmin} \\
 t_{DO} &\leq t_{DAmin} + t_{GTAmn} - t_{DPmax}
 \end{aligned}$$

The value of  $t_{DP}$  is a device parameter (see AC Electrical Characteristics) and  $t_{REC}$  is the minimum signal duration to be recognized by the receiver. A value for C1 of 0.1  $\mu$ F is recommended for most applications, leaving R1 to be selected by the designer. Different steering arrangements may be used to select independent tone present ( $t_{GTP}$ ) and tone absent ( $t_{GTA}$ ) guard times. This may be necessary to meet system specifications which place both accept and reject limits on tone duration and interdigital pause. Guard time adjustment also allows the designer to tailor system parameters such as talk-off and noise immunity.

Increasing  $t_{REC}$  improves talk-off performance since it reduces the probability that tones simulated by speech will maintain a valid signal condition long enough to be registered. Alternatively, a relatively short  $t_{REC}$  with a long  $t_{DO}$  would be appropriate for extremely noisy environments where fast acquisition time and immunity to tone drop-outs are required. Design information for guard time adjustment is shown in Figure 6. The receiver timing is shown in Figure 7 with a description of the events in Figure 8.

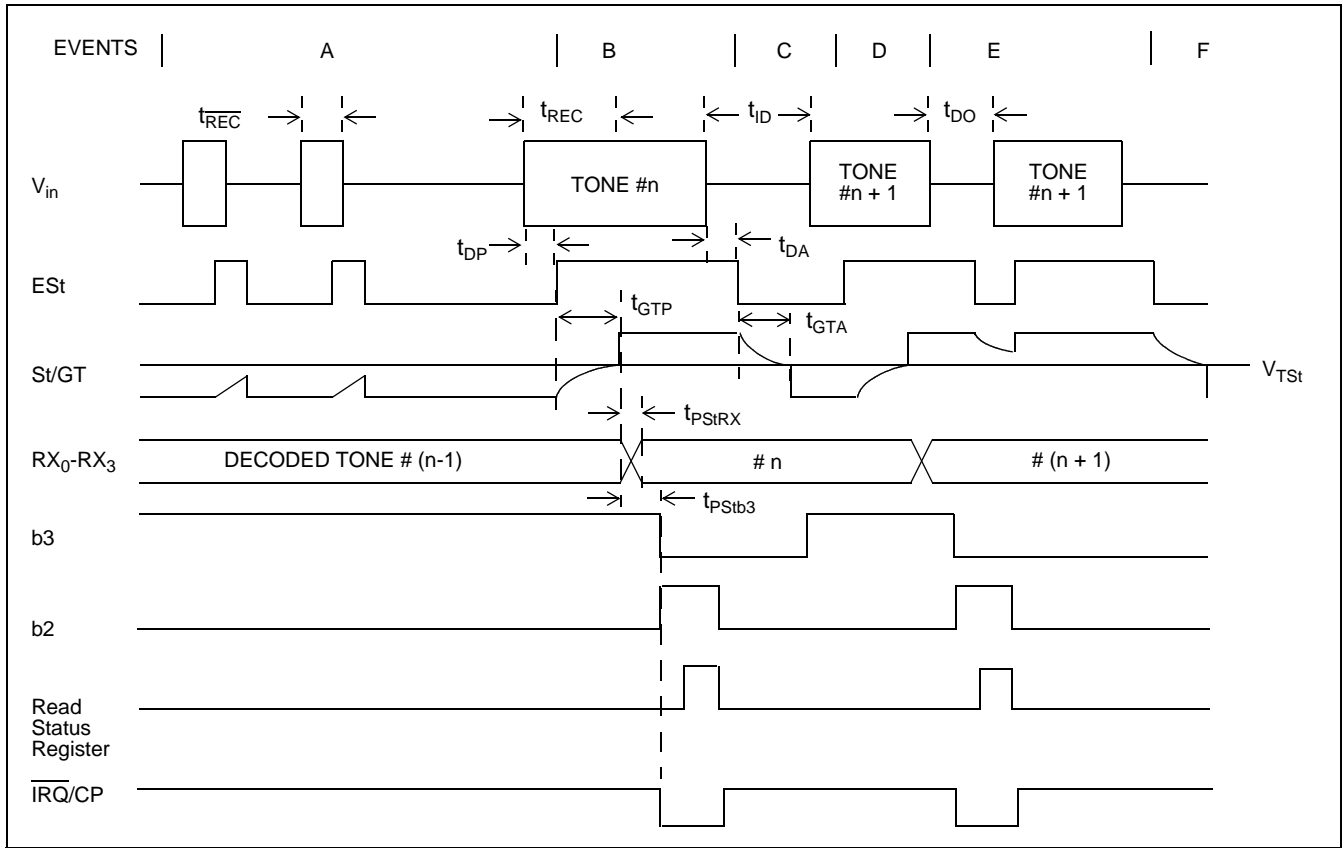

Figure 7 - Receiver Timing Diagram

**EXPLANATION OF EVENTS**

- A) TONE BURSTS DETECTED, TONE DURATION INVALID, RX DATA REGISTER NOT UPDATED.  
 B) TONE #n DETECTED, TONE DURATION VALID, TONE DECODED AND LATCHED IN RX DATA REGISTER.  
 C) END OF TONE #n DETECTED, TONE ABSENT DURATION VALID, INFORMATION IN RX DATA REGISTER RETAINED UNTIL NEXT VALID TONE PAIR.  
 D) TONE #n+1 DETECTED, TONE DURATION VALID, TONE DECODED AND LATCHED IN RX DATA REGISTER.  
 E) ACCEPTABLE DROPOUT OF TONE #n+1, TONE ABSENT DURATION INVALID, DATA REMAINS UNCHANGED.  
 F) END OF TONE #n+1 DETECTED, TONE ABSENT DURATION VALID, INFORMATION IN RX DATA REGISTER RETAINED UNTIL NEXT VALID TONE PAIR.

**EXPLANATION OF SYMBOLS**

$V_{in}$	DTMF COMPOSITE INPUT SIGNAL.
EST	EARLY STEERING OUTPUT. INDICATES DETECTION OF VALID TONE FREQUENCIES.
St/GT	STEERING INPUT/GUARD TIME OUTPUT. DRIVES EXTERNAL RC TIMING CIRCUIT.
$RX_0-RX_3$	4-BIT DECODED DATA IN RECEIVE DATA REGISTER
b3	DELAYED STEERING IN STATUS REGISTER (BIT 3) INDICATES THAT VALID FREQUENCIES HAVE BEEN PRESENT/ABSENT FOR THE REQUIRED GUARD TIME THUS CONSTITUTING A VALID SIGNAL. ACTIVE LOW FOR THE DURATION OF A VALID DTMF SIGNAL.
b2	RECEIVE DATA REGISTER FULL (BIT 2) IN STATUS REGISTER INDICATES THAT VALID DATA IS IN THE RECEIVE DATA REGISTER. THE BIT IS CLEARED AFTER THE STATUS REGISTER IS READ.
$\overline{IRQ/CP}$	INTERRUPT IS ACTIVE INDICATING THAT NEW DATA IS IN THE RX DATA REGISTER. THE INTERRUPT IS CLEARED AFTER THE STATUS REGISTER IS READ.
$t_{REC}$	MAXIMUM DTMF SIGNAL DURATION NOT DETECTED AS VALID. TYPICALLY 20MS.
$t_{REC}$	MINIMUM DTMF SIGNAL DURATION REQUIRED FOR VALID RECOGNITION. TYPICALLY 40MS.
$t_{ID}$	MINIMUM TIME BETWEEN VALID SEQUENTIAL DTMF SIGNALS. TYPICALLY 40MS.
$t_{DO}$	MAXIMUM ALLOWABLE DROPOUT DURING VALID DTMF SIGNAL. TYPICALLY 20MS.
$t_{DP}$	TIME TO DETECT VALID FREQUENCIES PRESENT.
$t_{DA}$	TIME TO DETECT VALID FREQUENCIES ABSENT.
$t_{GTP}$	GUARD TIME, TONE PRESENT.
$t_{GTA}$	GUARD TIME, TONE ABSENT.

**Figure 8 - Description of Timing Events****Call Progress Filter**

A call progress mode, using the MT88L89, can be selected to allow the detection of various tones, which identify the progress of a telephone call on the network. The call progress tone input and DTMF input are common, however, call progress tones can only be detected when CP mode has been selected. DTMF signals cannot be detected if CP mode has been selected (see Table 7). Figure 10 indicates the useful detect bandwidth of the call progress filter. Frequencies presented to the input, which are within the 'accept' bandwidth limits of the filter, are hard-limited by a high gain comparator with the  $\overline{IRQ/CP}$  pin serving as the output. The square-wave output obtained from the schmitt trigger can be analyzed by a microprocessor or counter arrangement to determine the nature of the call progress tone being detected. Frequencies which are in the 'reject' area will not be detected and consequently the  $\overline{IRQ/CP}$  pin will remain low.

**DTMF Generator**

The DTMF transmitter employed in the MT88L89 is capable of generating all sixteen standard DTMF tone pairs with low distortion and high accuracy. All frequencies are derived from an external 3.579545 MHz crystal. The sinusoidal waveforms for the individual tones are digitally synthesized by using row and column programmable dividers and switched capacitor D/A converters. The row and column tones are mixed and filtered to provide a DTMF signal with low total harmonic distortion and high accuracy. To specify a DTMF signal, data conforming to the encoding format shown in Table 1 must be written to the transmit Data Register. Note that Table 1 is the same as the receiver output code. The individual tones which are generated ( $f_{LOW}$  and  $f_{HIGH}$ ) are referred to as Low Group and High Group tones. As seen from the table, the low group frequencies are 697, 770, 852 and 941 Hz. The high group frequencies are 1209, 1336, 1477 and 1633 Hz. Typically, the high group to low group amplitude ratio (twist) is 2 dB to compensate for high group attenuation on long loops.



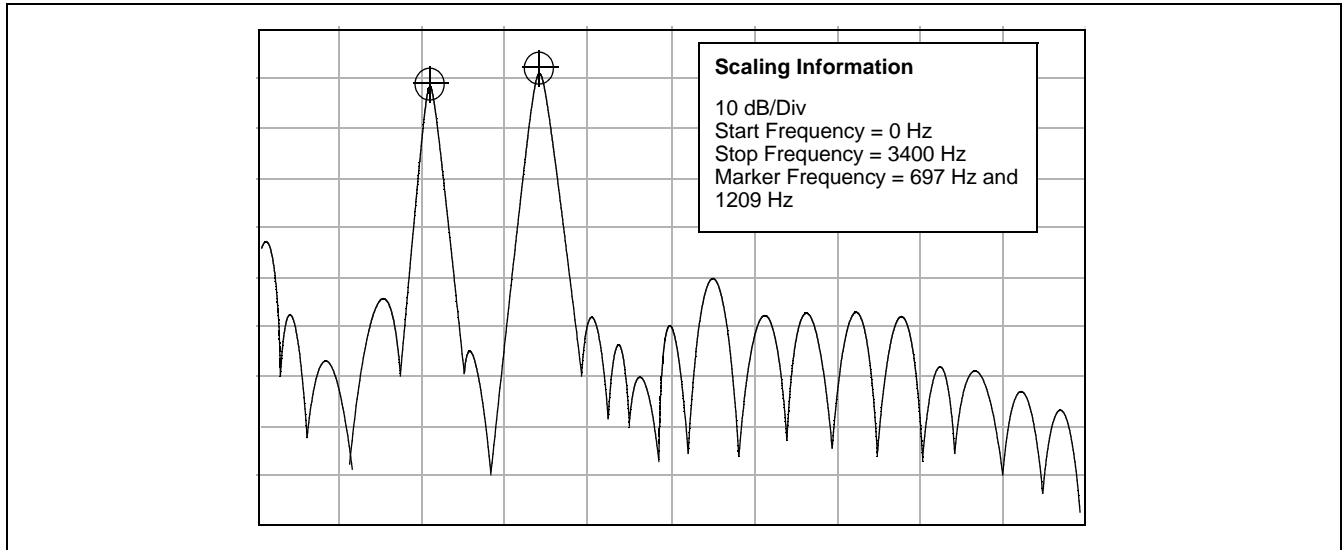

Figure 9 - Spectrum Plot

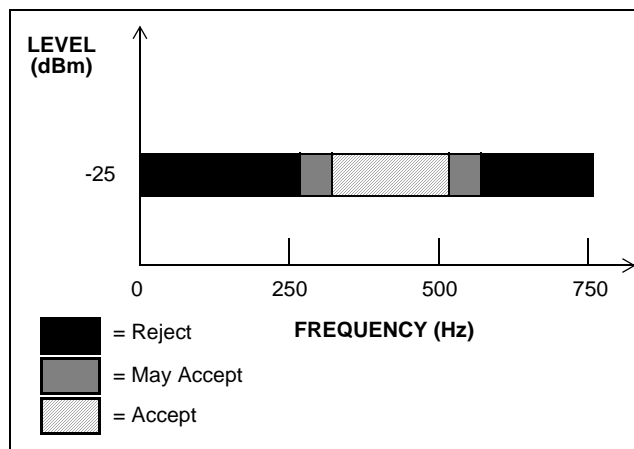

Figure 10 - Call Progress Response

The period of each tone consists of 32 equal time segments. The period of a tone is controlled by varying the length of these time segments. During write operations to the Transmit Data Register the 4 bit data on the bus is latched and converted to 2 of 8 coding for use by the programmable divider circuitry. This code is used to specify a time segment length, which will ultimately determine the frequency of the tone. When the divider reaches the appropriate count, as determined by the input code, a reset pulse is issued and the counter starts again. The number of time segments is fixed at 32, however, by varying the segment length as described above, the frequency can also be varied. The divider output clocks another counter, which addresses the sinewave lookup ROM.

The lookup table contains codes which are used by the switched capacitor D/A converter to obtain discrete and highly accurate DC voltage levels. Two identical circuits are employed to produce row and column tones, which are then mixed by using a low noise summing amplifier. A bandwidth limiting filter is incorporated and serves to attenuate distortion products above 8 kHz. Figure 9 shows that the distortion products are very low in amplitude.

## Burst Mode

In certain telephony applications it is required that DTMF signals being generated are of a specific duration determined either by the particular application or by any one of the exchange transmitter specifications currently existing. Standard DTMF signal timing can be accomplished by making use of the Burst Mode. The transmitter is capable of issuing symmetric bursts/pauses of predetermined duration. This burst/pause duration is 51 ms±1 ms which is a standard interval for autodialer and central office applications. After the burst/pause has been issued, the appropriate bit is set in the Status Register to indicate that the transmitter is ready for more data. The timing described above is available when DTMF mode has been selected. However, when CP mode (Call Progress mode) is selected, the burst/pause duration is doubled to 102 ms ±2 ms. Note that when CP mode and Burst mode have been selected, DTMF tones may only be transmitted and *not* received. In applications where a non-standard burst/pause time is desirable, a software timing loop or external timer can be used to provide the timing pulses when the burst mode is disabled by enabling and disabling the transmitter.

## Single Tone Generation

A single tone mode is available whereby individual tones from the low group or high group can be generated. This mode can be used for DTMF test equipment applications, acknowledgment tone generation and distortion measurements. Refer to Control Register B (CRB) description for details.

Active Input	Output Frequency (Hz)		%Error
	Specified	Actual	
L1	697	699.1	+0.30
L2	770	766.2	-0.49
L3	852	847.4	-0.54
L4	941	948.0	+0.74
H1	1209	1215.9	+0.57
H2	1336	1331.7	-0.32
H3	1477	1471.9	-0.35
H4	1633	1645.0	+0.73

Table 2 - Actual Frequencies Versus Standard Requirements

## Distortion Calculations

The MT88L89 is capable of producing precise tone bursts with minimal error in frequency (see Table 2). The internal summing amplifier is followed by a first-order lowpass switched capacitor filter to minimize harmonic components and intermodulation products. The total harmonic distortion for a *single tone* can be calculated by using Equation 1, which is the ratio of the total power of all the extraneous frequencies to the power of the fundamental frequency expressed as a percentage.

$$\text{THD (\%)} = 100 \frac{\left( V_{2f}^2 + V_{3f}^2 + V_{4f}^2 + \dots V_{nf}^2 \right)}{V_{\text{fundamental}}^2}$$

Equation 1. THD (%) For a Single Tone

The Fourier components of the tone output correspond to  $V_{2f} \dots V_{nf}$  as measured on the output waveform. The total harmonic distortion for a *dual tone* can be calculated by using Equation 2.  $V_L$  and  $V_H$  correspond to the low group amplitude and high group amplitude, respectively and  $V_{IMD}^2$  is the sum of all the intermodulation components. The internal switched-capacitor filter following the D/A converter keeps distortion products down to a very low level as shown in Figure 9.

$$THD (\%) = 100 \frac{\left( V_{2L}^2 + V_{3L}^2 + \dots + V_{nL}^2 + V_{2H}^2 + V_{3H}^2 + \dots + V_{nH}^2 + V_{IMD}^2 \right)}{V_L^2 + V_H^2}$$

**Equation 2. THD (%) For a Dual Tone**

### DTMF Clock Circuit

The internal clock circuit is completed with the additions of a standard television color burst crystal. The crystal specification is as follows:

- Frequency: 3.579545 MHz
- Frequency Tolerance:  $\pm 0.1\%$
- Resonance Mode: Parallel
- Load Capacitance: 18 pF
- Maximum Series Resistance: 150 ohms
- Maximum Drive Level: 2 mW

e.g. CTS Knights MP036S  
 Toyocom TQC-203-A-9S

A number of MT88L89 devices can be connected as shown in Figure 11 such that only one crystal is required. Alternatively, the OSC1 inputs on all devices can be driven from a CMOS buffer with the OSC2 outputs left unconnected.

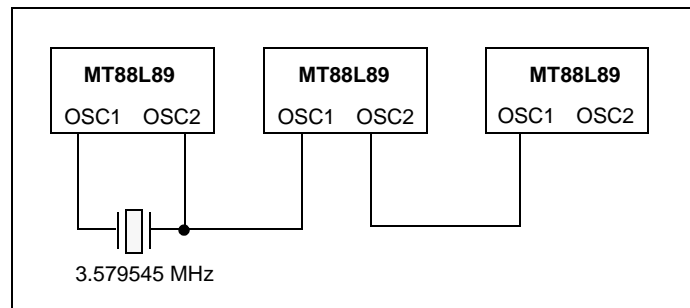

**Figure 11 - Common Crystal Connection**

## Microprocessor Interface

The MT88L89 design incorporates an adaptive interface, which allows it to be connected to various kinds of microprocessors. Key functions of this interface include the following:

- Continuous activity on  $\overline{DS/RD}$  is not necessary to update the internal status registers.
- Compatible with Motorola and Intel processors. Determines whether input timing is that of an Intel or Motorola controller by monitoring  $\overline{DS/RD}$ , on the  $\overline{CS}$  falling edge.
- Differentiates between multiplexed and non-multiplexed microprocessor buses. Address and data are latched in accordingly.

Figure 17 shows the timing diagram for the Motorola microcontrollers. The chip select ( $\overline{CS}$ ) input is formed by NANDing address strobe ( $\overline{AS}$ ) and address decode output. The MT88L89 examines the state of  $\overline{DS/RD}$  on the falling edge of  $\overline{CS}$ . For Motorola bus timing  $\overline{DS/RD}$  must be low on the falling edge of  $\overline{CS}$ . Figure 12(a) shows the connection of the MC68L11/MC68B11 Motorola processor to the MT88L89 DTMF transceiver.

Figures 18 and 19 are the timing diagrams for the Intel 8xL5x series (12 MHz) micro-controllers with multiplexed address and data buses. The MT88L89 latches in the state of  $\overline{DS/RD}$  on the falling edge of  $\overline{CS}$ . When  $\overline{DS/RD}$  is high, Intel processor operation is selected. By NANDing the address latch enable (ALE) output with the high-byte address (P2) decode output,  $\overline{CS}$  can be generated. Figure 12(b) shows the connection of these Intel processors to the MT88L89 transceiver.

**Note:** The adaptive micro interface relies on high-to-low transition on  $\overline{CS}$  to recognize the microcontroller interface. This pin must not be tied permanently low. Only one register access is allowed on any  $\overline{CS}$  assertion.

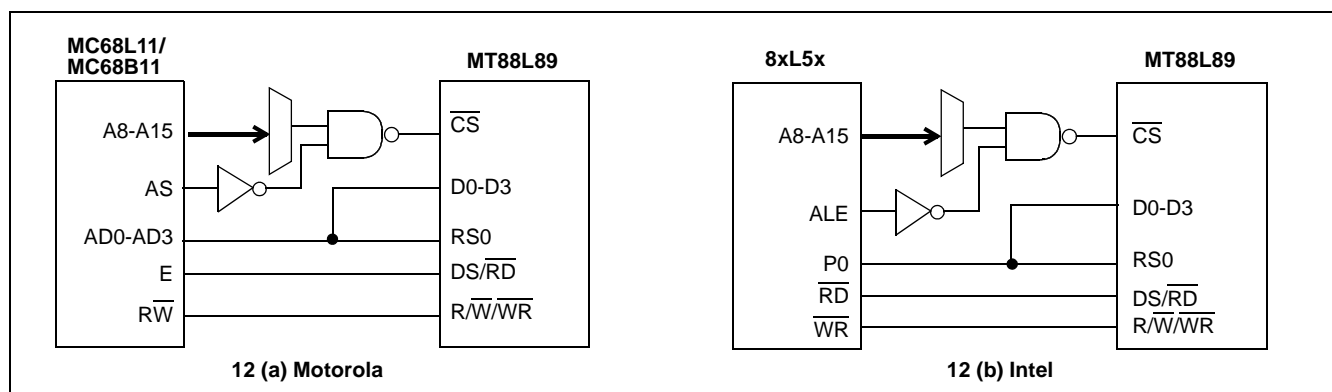

**Figure 12 a) & b) - MT88L89 Interface Connections for Various Intel and Motorola Micros**

The adaptive micro interface provides access to five internal registers. The read-only Receive Data Register contains the decoded output of the last valid DTMF digit received. Data entered into the write-only Transmit Data Register will determine which tone pair is to be generated (see Table 1 for coding details). Transceiver control is accomplished with two control registers (see Tables 6 and 7), CRA and CRB, which have the same address. A write operation to CRB is executed by first setting the most significant bit (b3) in CRA. The following write operation to the same address will then be directed to CRB, and subsequent write cycles will be directed back to CRA. The read-only status register indicates the current transceiver state (see Table 8).

A software reset must be included at the beginning of all programs to initialize the control registers upon power-up or power reset (see Figure 15). Refer to Tables 4-7 for bit descriptions of the two control registers.

The multiplexed  $\overline{IRQ/CP}$  pin can be programmed to generate an interrupt upon validation of DTMF signals or when the transmitter is ready for more data (burst mode only). Alternatively, this pin can be configured to provide a square-wave output of the call progress signal. The  $\overline{IRQ/CP}$  pin is an open drain output and requires an external pull-up resistor (see Figure 13 and Figure 14).

RS0	Motorola	Intel		Function
	R/W	WR	RD	
0	0	0	1	Write to Transmit Data Register
0	1	1	0	Read from Receive Data Register
1	0	0	1	Write to Control Register
1	1	1	0	Read from Status Register

**Table 3 - Internal Register Functions**

b3	b2	b1	b0
RSEL	IRQ	CP/DTMF	TOUT

**Table 4 - CRA Bit Positions**

b3	b2	b1	b0
C/R	S/D	RxEN	BURST ENABLE

**Table 5 - CRB Bit Positions**

Bit	Name	Description
b0	TOUT	Tone Output Control. A logic high enables the tone output; a logic low puts the DTMF transmitter in power-down mode. The TONE output pin is held in high impedance and the transmit register is cleared. See Note 1 below.
b1	CP/DTMF	Call Progress or DTMF Mode Select. A logic high enables the receive call progress mode; a logic low enables DTMF mode. In DTMF mode the device is capable of receiving and transmitting DTMF signals. In CP mode a rectangular wave representation of the received tone signal will be present on the $\overline{IRQ/CP}$ output pin if IRQ has been enabled (Control Register A, b2=1). In order to be detected, CP signals must be within the bandwidth specified in the AC Electrical Characteristics for Call Progress. Note: DTMF signals cannot be detected when CP mode is selected.
b2	IRQ	Interrupt Enable. A logic high enables the interrupt function; a logic low de-activates the interrupt function. When IRQ is enabled and DTMF mode is selected (Control Register A, b1=0), the $\overline{IRQ/CP}$ output pin will go low when either 1) a valid DTMF signal has been received for a valid guard time duration, or 2) the transmitter is ready for more data (burst mode only).
b3	RSEL	Register Select. A logic high selects Control Register B for the next write cycle to the control register address. After writing to Control Register B, the following control register write cycle will be directed to Control Register A.

**Table 6 - Control Register A Description**

Bit	Name	Description
b0	$\overline{\text{BURST}}$	<p>Burst Mode Select. A logic high de-activates burst mode; a logic low enables burst mode. When activated, the digital code representing a DTMF signal (see Table 1) can be written to the transmit register, which will result in a transmit DTMF tone burst and pause of equal durations (typically 51 msec). Following the pause, the status register will be updated (b1 - Transmit Data Register Empty), and an interrupt will occur if the interrupt mode has been enabled.</p> <p>When CP mode (Control Register A, b1) is enabled the normal tone burst and pause durations are extended from a typical duration of 51 msec to 102 msec.</p> <p>When <math>\overline{\text{BURST}}</math> is high (de-activated) the transmit tone burst duration is determined by the TOUT bit (Control Register A, b0).</p>
b1	$\overline{\text{RxEN}}$	This bit enables the DTMF and Call Progress Tone receivers. A logic low enables both circuits. A logic high deactivates and puts both receiver circuits into power-down mode. See Note 1 below.
b2	$\text{S}/\overline{\text{D}}$	Single or Dual Tone Generation. A logic high selects the single tone output; a logic low selects the dual tone (DTMF) output. The single tone generation function requires further selection of either the row or column tones (low or high group) through the C/R bit (Control Register B, b3).
b3	$\text{C}/\overline{\text{R}}$	Column or Row Tone Select. A logic high selects a column tone output; a logic low selects a row tone output. This function is used in conjunction with the S/D bit (Control Register B, b2).

**Table 7 - Control Register B Description**

Note 1: When both TOUT and  $\overline{\text{RxEN}}$  are asserted to power-down, the crystal oscillator and the Vref circuits are powered down.

Bit	Name	Status Flag Set	Status Flag Cleared
b0	IRQ	Interrupt has occurred. Bit one (b1) or bit two (b2) is set.	Interrupt is inactive. Cleared after Status Register is read.
b1	TRANSMIT DATA REGISTER EMPTY (BURST MODE ONLY)	Pause duration has terminated and transmitter is ready for new data.	Cleared after Status Register is read or when in non-burst mode.
b2	RECEIVE DATA REGISTER FULL	Valid data is in the Receive Data Register.	Cleared after Status Register is read.
b3	$\overline{\text{DELAYED STEERING}}$	Set upon the valid detection of the absence of a DTMF signal.	Cleared upon the detection of a valid DTMF signal.

**Table 8 - Status Register Description**

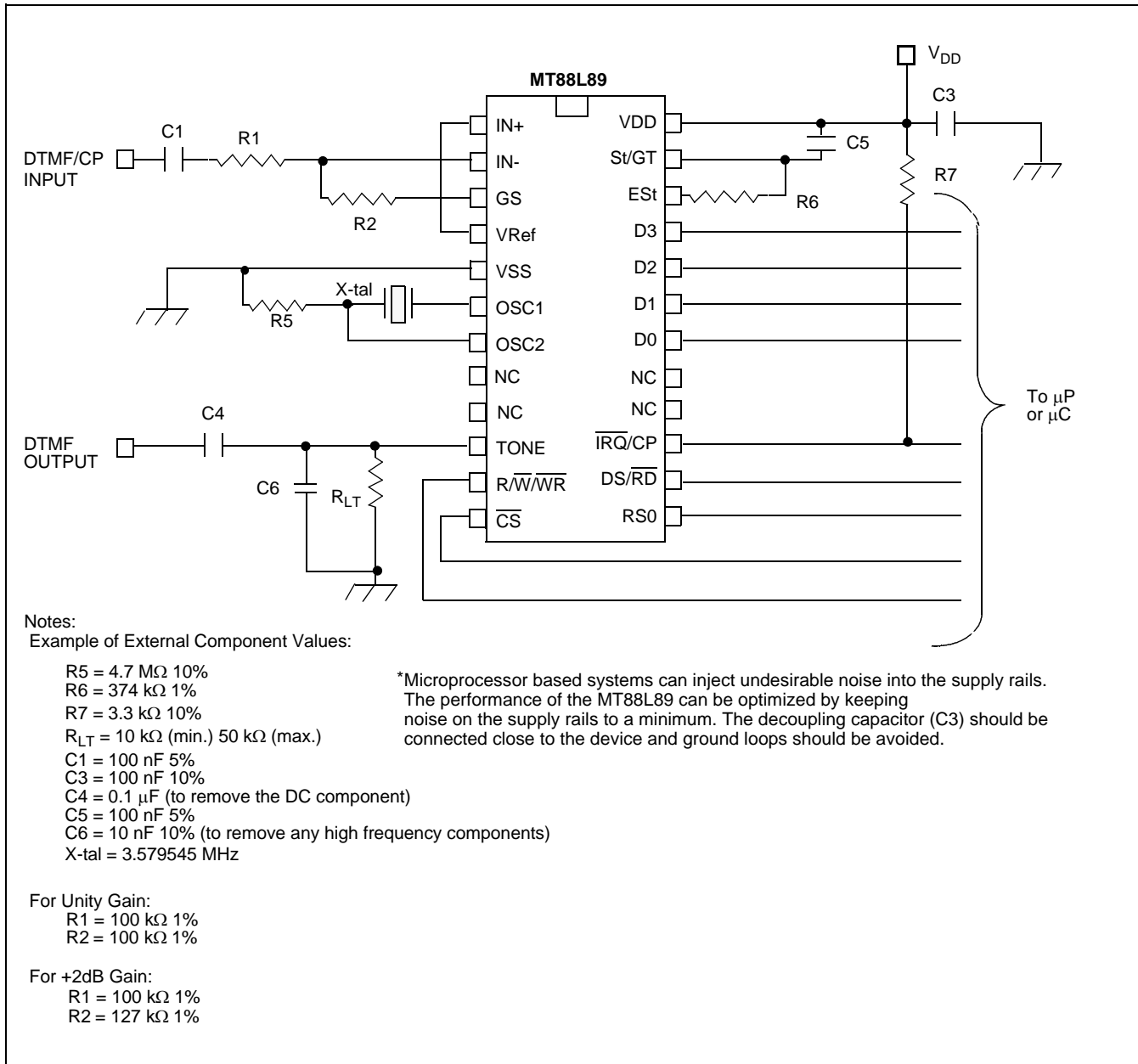

Figure 13 - Application Circuit (Single-Ended Input Configuration)

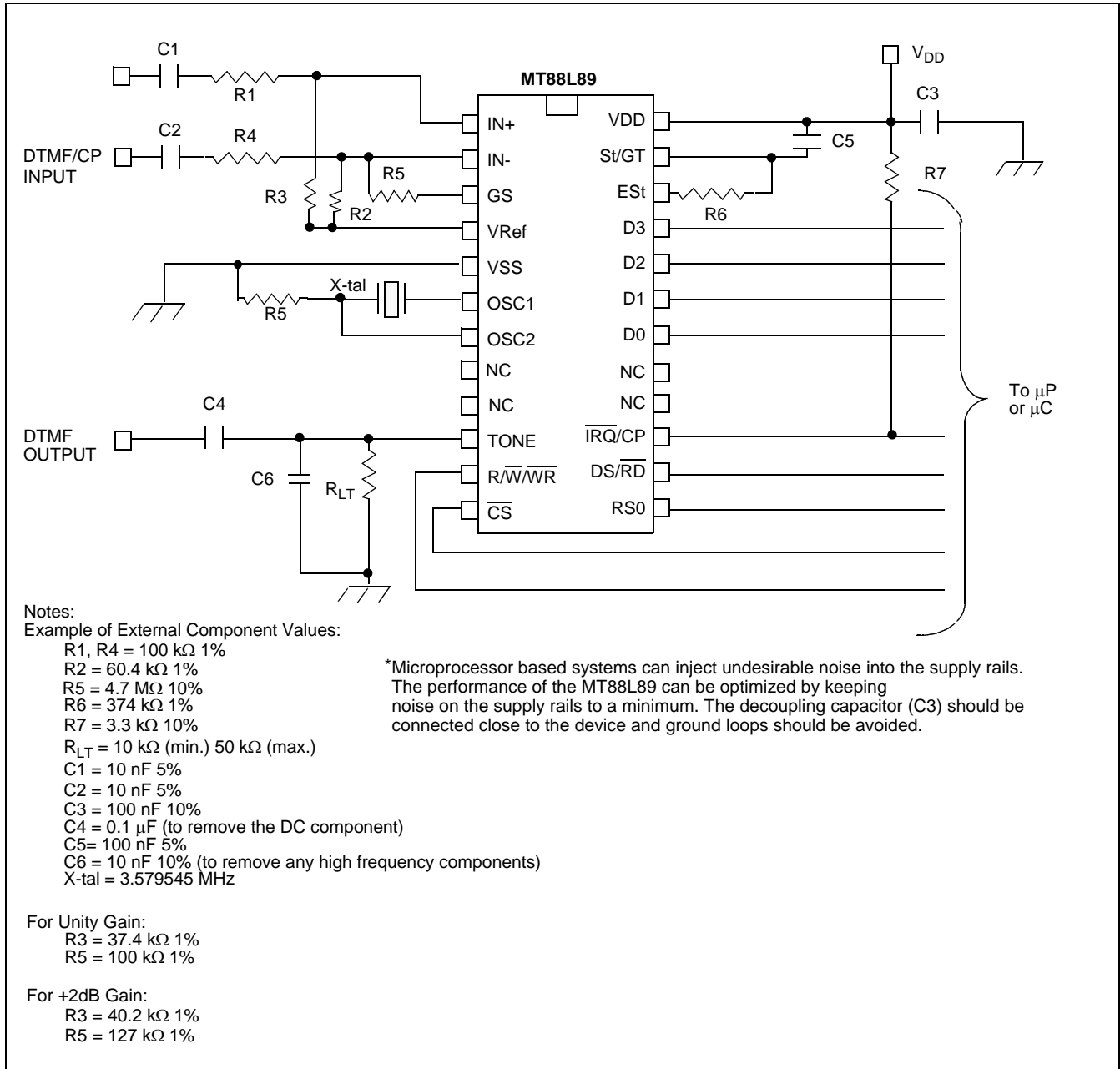

Figure 14 - Application Circuit (Differential Input Configuration)



### Initialization Procedure

A software reset must be included at the beginning of all programs to initialize the control registers after power up.

#### Description:

	<u>Motorola</u>		<u>Intel</u>		Data			
	RS0	R/W	WR	RD	b3	b2	b1	b0
1) Read Status Register	1	1	1	0	X	X	X	X
2) Write to Control Register	1	0	0	1	0	0	0	0
3) Write to Control Register	1	0	0	1	0	0	0	0
4) Write to Control Register	1	0	0	1	1	0	0	0
5) Write to Control Register	1	0	0	1	0	0	0	0
6) Read Status Register	1	1	1	0	X	X	X	X

### Typical Control Sequence for Burst Mode Applications

Transmit DTMF tones of 50 ms burst/50 ms pause and Receive DTMF Tones.

#### Sequence:

	RS0	R/W	WR	RD	b3	b2	b1	b0
1) Write to Control Register A (tone out, DTMF, IRQ, Select Control Register B)	1	0	0	1	1	1	0	1
2) Write to Control Register B (burst mode)	1	0	0	1	0	0	0	0
3) Write to Transmit Data Register (send a digit 7)	0	0	0	1	0	1	1	1
4) Wait for an Interrupt or Poll Status Register								
5) Read the Status Register	1	1	1	0	X	X	X	X
-if bit 1 is set, the Tx is ready for the next tone, in which case...								
Write to Transmit Register (send a digit 5)	0	0	0	1	0	1	0	1
-if bit 2 is set, a DTMF tone has been received, in which case....								
Read the Receive Data Register	0	1	1	0	X	X	X	X
-if both bits are set...								
Read the Receive Data Register	0	1	1	0	X	X	X	X
Write to Transmit Data Register	0	0	0	1	0	1	0	1

**NOTE: IN THE TX BURST MODE, STATUS REGISTER BIT 1 WILL NOT BE SET UNTIL 100 ms ( $\pm 2$  ms) AFTER THE DATA IS WRITTEN TO THE TX DATA REGISTER. IN EXTENDED BURST MODE THIS TIME WILL BE DOUBLED TO 200 ms ( $\pm 4$  ms)**

Figure 15 - Application Notes

**Absolute Maximum Ratings\***

	Parameter	Symbol	Min.	Max.	Units
1	Power supply voltage $V_{DD}-V_{SS}$	$V_{DD}-V_{SS}$		5.5	V
2	Voltage on any pin	$V_I$	$V_{SS}-0.3$	$V_{DD}+0.3$	V
3	Current at any pin (Except $V_{DD}$ and $V_{SS}$ )			10	mA
4	Storage temperature	$T_{ST}$	-65	+150	°C
5	Package power dissipation	$P_D$		1000	mW

\* Exceeding these values may cause permanent damage. Functional operation under these conditions is not implied.

**Recommended Operating Conditions -** Voltages are with respect to ground ( $V_{SS}$ ) unless otherwise stated.

	Parameter	Sym.	Min.	Typ. <sup>‡</sup>	Max.	Units	Test Conditions
1	Positive power supply	$V_{DD}$	2.7	3	3.6	V	
2	Operating temperature	$T_O$	-40		+85	°C	
3	Crystal clock frequency	$f_{CLK}$	3.575965	3.579545	3.583124	MHz	

‡ Typical figures are at 25°C and for design aid only: not guaranteed and not subject to production testing.

**DC Electrical Characteristics** <sup>†</sup> -  $V_{SS}=0$  V.

		Characteristics	Sym.	Min.	Typ. <sup>‡</sup>	Max.	Units	Test Conditions
1	S U P P L Y	Standby supply current	$I_{DDQ}$		2.0 3.0	15.0 15.0	μA	$V_{DD} = 2.7V$  $V_{DD} = 3.6V$  TOUT and $\overline{RxEN}$ bits asserted to power-down mode
2		Transmitter supply current	$I_{DDTX}$		2.0	7.0	mA	Transmitter fully enabled and $\overline{RxEN}$ bit asserted to power-down mode
3		Receiver supply current	$I_{DDRX}$		3.0	5.0	mA	Receiver fully enabled and TOUT bit asserted to power-down mode
4		Operating supply current	$I_{DD}$		3.1	7.0	mA	Device fully enabled
5	I N P U T S	High level input voltage (OSC1)	$V_{IHO}$	$0.7 V_{DD}$			V	
6		Low level input voltage (OSC1)	$V_{ILO}$			$0.3 V_{DD}$	V	
7		Steering threshold voltage	$V_{Tst}$	$0.43 V_{DD}$	$0.46 V_{DD}$	$0.51 V_{DD}$	V	$V_{DD} = 3V$

**DC Electrical Characteristics (continued)<sup>†</sup>** -  $V_{SS}=0$  V.

		Characteristics	Sym.	Min.	Typ. <sup>‡</sup>	Max.	Units	Test Conditions
8	O U T P U T S	Low level output voltage (OSC2)	$V_{OLO}$			$0.1 V_{DD}$	V	No load
9		High level output voltage (OSC2)	$V_{OHO}$	$0.9 V_{DD}$			V	No load
10		Output leakage current (IRQ) (Tone)	$I_{OZT}$		1	10	$\mu$ A	
11		$V_{Ref}$ output voltage	$V_{Ref}$	$0.47 V_{DD}$		$0.53 V_{DD}$	V	No load
12		$V_{Ref}$ output resistance	$R_{OR}$			2.5	k $\Omega$	Note 9
13	D i g i t a l	Low level input voltage	$V_{IL}$			$0.3 V_{DD}$	V	
14		High level input voltage	$V_{IH}$	$0.7 V_{DD}$			V	
15		Input leakage current	$I_{IZ}$			10	$\mu$ A	$V_{IN}=V_{SS}$ to $V_{DD}$
16		Output high impedance	$I_{OZD}$			10	$\mu$ A	$V_{IN}=V_{SS}$ to $V_{DD}$
17	Data Bus	Source current	$I_{OHD}$	1.0	3.8		mA	$V_{OH}=0.9V_{DD}$
18		Sink current	$I_{OLD}$	1.5	4.0		mA	$V_{OL}=0.1V_{DD}$
19	ESt and St/GT	Source current	$I_{OHE}$	0.5	2.8		mA	$V_{OH}=0.9V_{DD}$
20		Sink current	$I_{OLE}$	1.5	4		mA	$V_{OL}=0.1V_{DD}$
21	IRQ/CP	Sink current	$I_{OLI}$	0.7	9		mA	$V_{OL}=0.1V_{DD}$

<sup>†</sup> Characteristics are over recommended operating conditions unless otherwise stated.

<sup>‡</sup> Typical figures are at 25°C,  $V_{DD} = 5$  V and for design aid only; not guaranteed and not subject to production testing.

\* See "Notes" following AC Electrical Characteristics Tables.

**Electrical Characteristics**

**Gain Setting Amplifier** - Voltages are with respect to ground ( $V_{SS}$ ) unless otherwise stated,  $V_{SS} = 0$  V,  $V_{DD} = 3$  V,  $T_O = 25^\circ\text{C}$ .

	Characteristics	Sym.	Min.	Typ. <sup>‡</sup>	Max.	Units	Test Conditions
1	Input leakage current	$I_{IN}$			100	nA	$V_{SS} \leq V_{IN} \leq V_{DD}$ Note 9
2	Input resistance	$R_{IN}$	10			M $\Omega$	Note 9
3	Input offset voltage	$V_{OS}$			25	mV	Note 9
4	Power supply rejection	PSRR	50			dB	1 kHz, See Note 9
5	Common mode rejection	CMRR	40			dB	$V_{SS} + 0.75V \leq V_{IN} \leq V_{DD} - 0.75V$ biased at $V_{REF} = 1.5V$ Note 9
6	DC open loop voltage gain	$A_{VOL}$	32			dB	Note 9
7	Unity gain bandwidth	fc	0.3			MHz	Note 9
8	Output voltage swing	$V_O$	2.2			$V_{pp}$	$R_{LGS} \geq 100$ k $\Omega$ to $V_{SS}$ at GS, 3 KHz Note 9
9	Allowable capacitive load (GS)	$C_{LGS}$			100	pF	Note 9
10	Allowable resistive load (GS)	$R_{LGS}$	50			k $\Omega$	Note 9

**Electrical Characteristics****Gain Setting Amplifier** - Voltages are with respect to ground ( $V_{SS}$ ) unless otherwise stated,  $V_{SS} = 0\text{ V}$ ,  $V_{DD} = 3\text{ V}$ ,  $T_O = 25^\circ\text{C}$ .

	Characteristics	Sym.	Min.	Typ. <sup>‡</sup>	Max.	Units	Test Conditions
11	Common mode range	$V_{CM}$		1.5		$V_{pp}$	$V_{DD} = 3\text{ V}$ , No Load Note 9

<sup>‡</sup> Typical figures are at 25°C and for design aid only: not guaranteed and not subject to production testing.**MT88L89 AC Electrical Characteristics<sup>†</sup>** - Voltages are with respect to ground ( $V_{SS}$ ) unless otherwise stated.

		Characteristics	Sym.	Min.	Typ. <sup>‡</sup>	Max.	Units	Notes*	
1	R X	Valid input signal levels (each tone of composite signal)		-29		-4	dBm	1,2,3,5,6,13	
				27.5		489	mV <sub>RMS</sub>	1,2,3,5,6	
2	R X	Positive twist accept				8	dB	2,3,6,9	
3		Negative twist accept				8	dB	2,3,6,9	
4		Freq. deviation accept		$\pm 1.5\% \pm 2\text{ Hz}$				2,3,5	
5		Freq. deviation reject		$\pm 3.5\%$				2,3,5	
6		Third tone tolerance					-16	dB	2,3,4,5,9,10
7		Noise tolerance					-12	dB	2,3,4,5,7,9,10
8		Dial tone tolerance			22			dB	2,3,4,5,8,9

<sup>†</sup> Characteristics are over recommended operating conditions unless otherwise stated.<sup>‡</sup> Typical figures are at 25°C,  $V_{DD} = 3\text{ V}$ , and for design aid only: not guaranteed and not subject to production testing.

\* \*See "Notes" following AC Electrical Characteristics Tables.

**AC Electrical Characteristics<sup>†</sup> - Call Progress** - Voltages are with respect to ground ( $V_{SS}$ ), unless otherwise stated.

	Characteristics	Sym.	Min.	Typ. <sup>‡</sup>	Max.	Units	Conditions
1	Accept Bandwidth	$f_A$	320		500	Hz	@ -25 dBm Note 9
2	Lower freq. (REJECT)	$f_{LR}$			290	Hz	@ -25 dBm Note 9
3	Upper freq. (REJECT)	$f_{HR}$	540			Hz	@ -25 dBm Note 9
4	Call progress tone detect level (total power)					dBm	

<sup>†</sup> Characteristics are over recommended operating conditions unless otherwise stated<sup>‡</sup> Typical figures are at 25°C,  $V_{DD} = 3\text{ V}$ , and for design aid only: not guaranteed and not subject to production testing

**AC Electrical Characteristics**<sup>†</sup> - Voltages are with respect to ground ( $V_{SS}$ ), unless otherwise stated.

		Characteristics	Sym.	Min.	Typ. <sup>‡</sup>	Max.	Units	Conditions
1	T O N E  I N	Tone present detect time	$t_{DP}$	5	11	14	ms	Note 11
2		Tone absent detect time	$t_{DA}$	0.5	4	8.5	ms	Note 11
3		Delay St to b3	$t_{PStb3}$			20	$\mu$ s	Figure 7, Note 9
4		Delay St to RX <sub>0</sub> -RX <sub>3</sub>	$t_{PStRX}$			11	$\mu$ s	Figure 7, Note 9
5	T O N E  O U T	Tone burst duration	$t_{BST}$	50		52	ms	DTMF mode
6		Tone pause duration	$t_{PS}$	50		52	ms	DTMF mode
7		Tone burst duration (extended)	$t_{BSTE}$	100		104	ms	Call Progress mode
8		Tone pause duration (extended)	$t_{PSE}$	100		104	ms	Call Progress mode
9		High group output level	$V_{HOUT}$	-17.3		-13.3	dBm	$R_{LT}=10k\Omega$
10		Low group output level	$V_{LOUT}$	-19.3		-15.3	dBm	$R_{LT}=10k\Omega$
11		Pre-emphasis	dB <sub>P</sub>		2	3	dB	$R_{LT}=10k\Omega$
12		Output distortion (Single Tone)	THD			-35	dB	25 kHz Bandwidth
13								$R_{LT}=10k\Omega$ , Note 9
14		Frequency deviation	$f_D$		$\pm 0.7$	$\pm 1.5$	%	$f_C=3.579545$ MHz
15	Output load resistance	$R_{LT}$	10		50	k $\Omega$	Note 9	
16	X T A L	Crystal/clock frequency	$f_C$	3.5759	3.5795	3.5831	MHz	Note 9
17		Clock input rise and fall time	$t_{CLRF}$			110	ns	Ext. clock, Note 9
18		Clock input duty cycle	DC <sub>CL</sub>	40	50	60	%	Ext. clock, Note 9
19		OSC2 load capacitance	$C_{LO}$			30	pF	
20		Oscillator start-up time	$t_{OST}$			10	ms	Note 9

<sup>†</sup> Timing is over recommended temperature & power supply voltages.

<sup>‡</sup> Typical figures are at 25°C and for design aid only: not guaranteed and not subject to production testing.

**AC Electrical Characteristics**<sup>†</sup>- MPU Interface - Voltages are with respect to ground ( $V_{SS}$ ), unless otherwise stated.

	Characteristics	Sym.	Min.	Typ. <sup>‡</sup>	Max.	Units	Conditions
1	$\overline{RD}/\overline{WR}$ low pulse width	$t_{CL}$	200	400		ns	Figure 16, Note 12 $t_{CL} + t_{CH} \geq 1000$ ns
2	DS high pulse width	$t_{CH}$	200	400		ns	Figure 16, Note 12 $t_{CL} + t_{CH} \geq 1000$ ns
3	Rise and fall time all digital inputs	$t_R, t_F$			20	ns	Figure 16
4	$\overline{R}/\overline{W}$ setup time	$t_{RWS}$	23			ns	Figures 17
5	$\overline{R}/\overline{W}$ hold time	$t_{RWH}$	26			ns	Figures 17
6	Address setup time (RS0)	$t_{AS}$	0			ns	Figures 17 - 19
7	Address hold time (RS0)	$t_{AH}$	45			ns	Figures 17 - 19
8	Data hold time (read)	$t_{DHR}$	22			ns	Figures 17 - 18
9	$\overline{DS}/\overline{RD}$ to valid data delay (read)	$t_{DDR}$			125	ns	Figures 17 - 18

**AC Electrical Characteristics<sup>†</sup> - MPU Interface** - Voltages are with respect to ground ( $V_{SS}$ ), unless otherwise stated.

	Characteristics	Sym.	Min.	Typ. <sup>‡</sup>	Max.	Units	Conditions
10	Data setup time (write)	$t_{DSW}$	60			ns	Figures 17, 19
11	Data hold time (write)	$t_{DHW}$	10			ns	Figures 17, 19
12	Chip select setup time	$t_{CSS}$	45			ns	Figures 17 - 19
13	Chip select hold time	$t_{CSH}$	10			ns	Figures 17 - 19
14	DS/RD set up time prior to $\overline{CS}$ assertion	$t_{RDS}, t_{DSS}$	20			ns	Figures 17, 19

<sup>†</sup> Characteristics are over recommended operating conditions unless otherwise stated

<sup>‡</sup> Typical figures are at 25°C,  $V_{DD} = 3\text{ V}$ , and for design aid only: not guaranteed and not subject to production testing

- NOTES:**
- 1) dBm = decibels above or below a reference power of 1 mW into a 600 ohm load
  - 2) Digit sequence consists of all 16 DTMF tones
  - 3) Tone duration = 40 ms. Tone pause = 40 ms
  - 4) Nominal DTMF frequencies are used
  - 5) Both tones in the composite signal have an equal amplitude
  - 6) The tone pair is deviated by  $\pm 1.5\% \pm 2\text{ Hz}$
  - 7) Bandwidth limited (3 kHz) Gaussian noise
  - 8) The precise dial tone frequencies are 350 and 440 Hz ( $\pm 2\%$ )
  - 9) Guaranteed by design and characterization. Not subject to production testing
  - 10) Referenced to the lowest amplitude tone in the DTMF signal
  - 11) For guard time calculation purposes
  - 12) Operation of microprocessor interface requires that  $t_{CL} + t_{CH} \geq 1000\text{ ns}$
  - 13) For Unity Gain Configuration

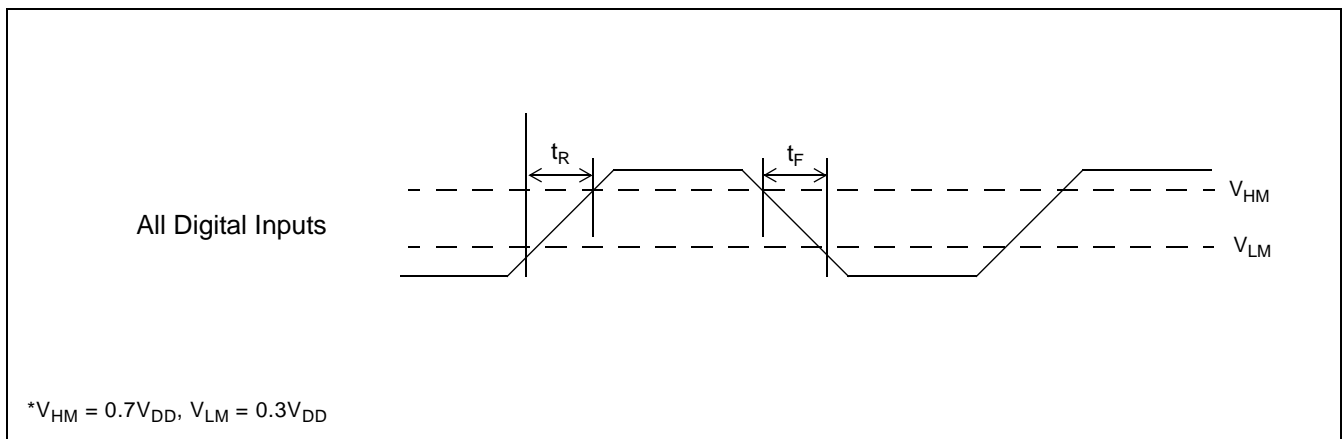

**Figure 16 - Digital Signal Input Rise/Fall Times**

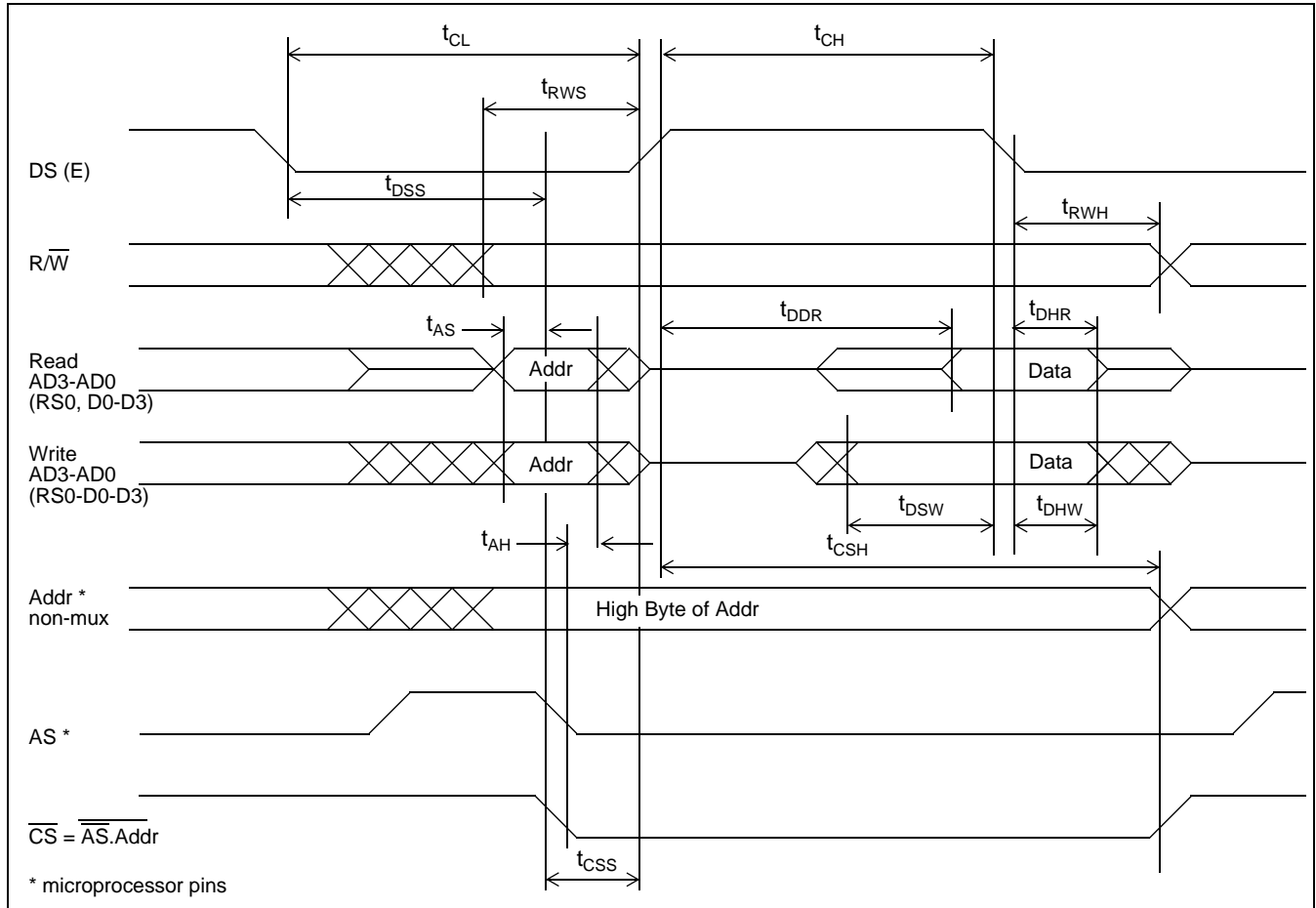

Figure 17 - Motorola BUS Timing Diagram

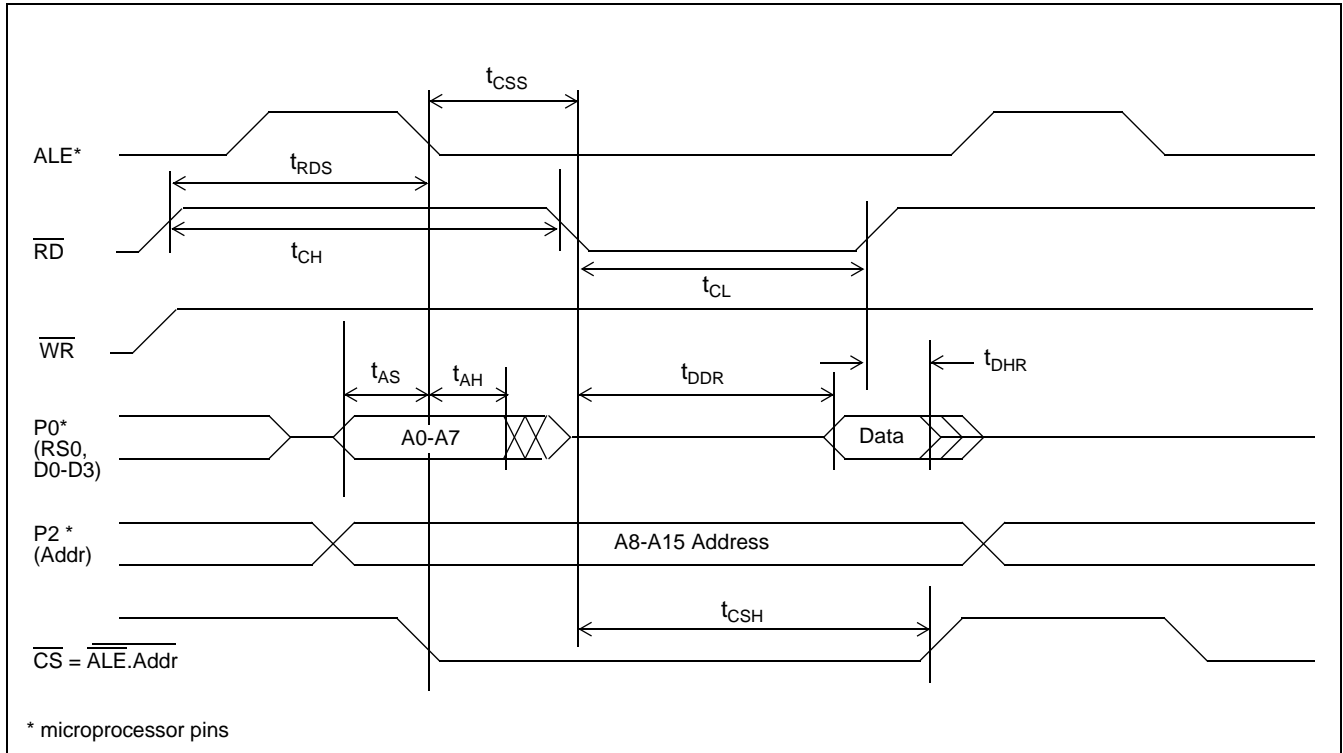

Figure 18 - Intel Read Timing Diagram

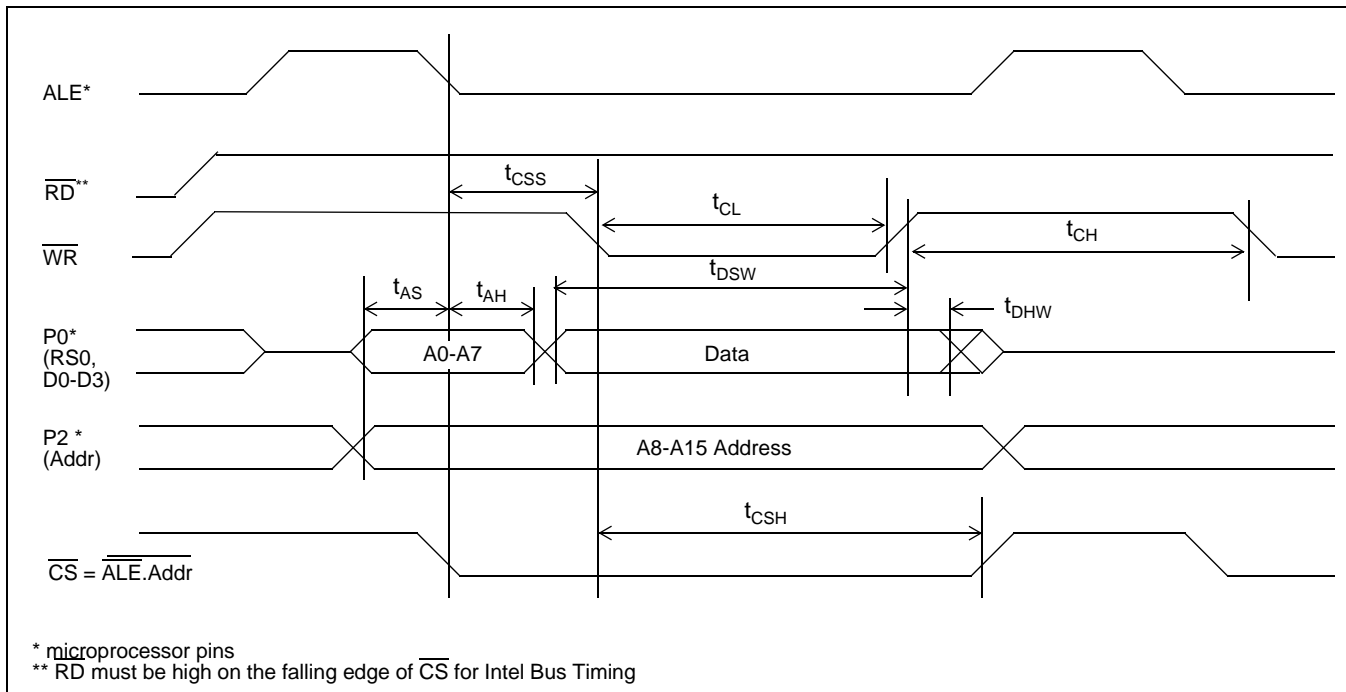
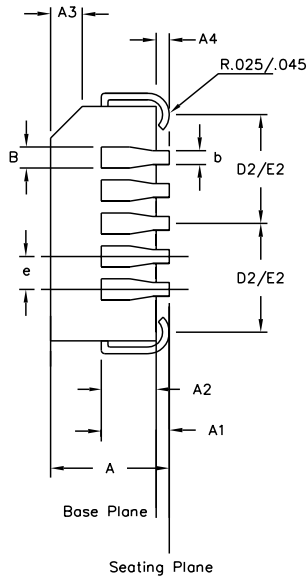
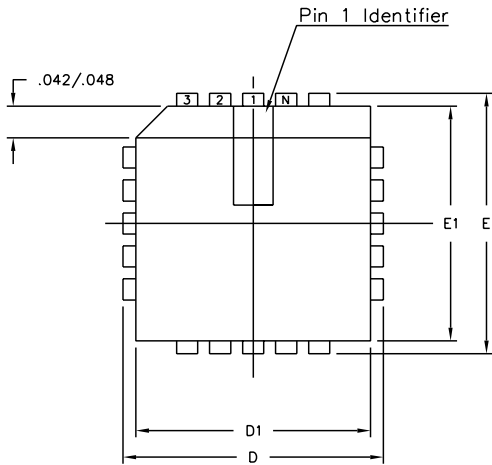

Figure 19 - Intel Write Timing Diagram





Symbol	Control Dimensions in inches		Altern. Dimensions in millimetres	
	MIN	MAX	MIN	MAX
A	0.165	0.180	4.19	4.57
A1	0.090	0.120	2.29	3.05
A2	0.062	0.083	1.57	2.11
A3	0.042	0.056	1.07	1.42
A4	0.020	—	0.51	—
D	0.485	0.495	12.32	12.57
D1	0.450	0.456	11.43	11.58
D2	0.191	0.219	4.85	5.56
E	0.485	0.495	12.32	12.57
E1	0.450	0.456	11.43	11.58
E2	0.191	0.219	4.85	5.56
B	0.026	0.032	0.66	0.81
b	0.013	0.021	0.33	0.53
e	0.050	BSC	1.27	BSC
Pin features				
ND	7			
NE	7			
N	28			
Note	Square			
Conforms to JEDEC MS-018AB Iss. A				

- Notes:
1. All dimensions and tolerances conform to ANSI Y14.5M-1982
  2. Dimensions D1 and E1 do not include mould protrusions. Allowable mould protrusion is 0.010" per side. Dimensions D1 and E1 include mould protrusion mismatch and are determined at the parting line, that is D1 and E1 are measured at the extreme material condition at the upper or lower parting line.
  3. Controlling dimensions in Inches.
  4. "N" is the number of terminals.
  5. Not To Scale
  6. Dimension R required for 120° minimum bend.

© Zarlink Semiconductor 2002 All rights reserved.				
ISSUE	1	2	3	
ACN	5958	207469	212422	
DATE	15Aug94	10Sep99	22Mar02	
APPRD.				



		Package Code	QA
Previous package codes		Package Outline for 28 lead PLCC	
HP / P		GPD00002	

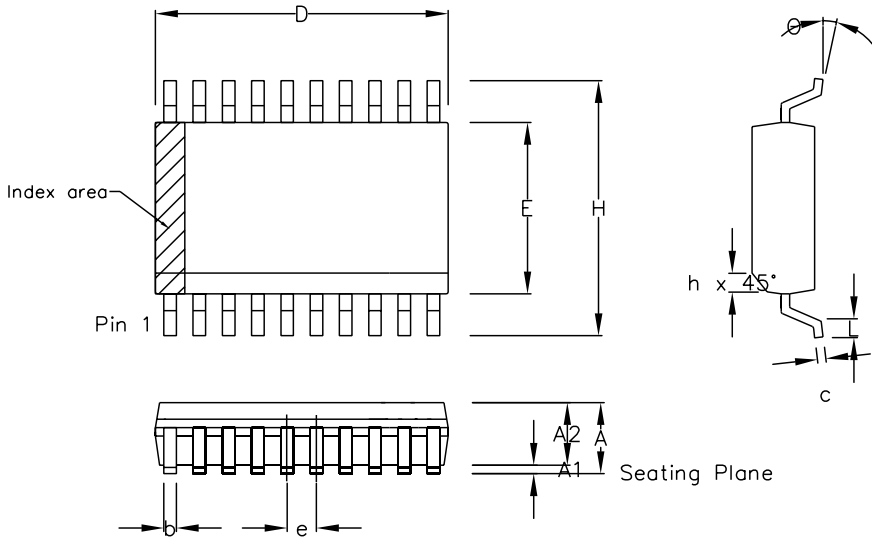

Symbol	Control Dimensions in millimetres			Altern. Dimensions in inches		
	MIN	Nominal	MAX	MIN	Nominal	MAX
A	2.35		2.65	0.093		0.104
A1	0.10		0.30	0.004		0.012
A2	2.25		2.35	0.089		0.092
D	12.60		13.00	0.496		0.512
H	10.00		10.65	0.394		0.419
E	7.40		7.60	0.291		0.299
L	0.40		1.27	0.016		0.050
e	1.27 BSC.			0.050 BSC.		
b	0.33		0.51	0.013		0.020
c	0.23		0.32	0.009		0.013
θ	0°		8°	0°		8°
h	0.25		0.75	0.010		0.029
Pin features						
N	20					
Conforms to JEDEC MS-013AC Iss. C						

- Notes:
1. The chamfer on the body is optional. If it not present, a visual index feature, e.g. a dot, must be located within the cross-hatched area.
  2. Controlling dimension are in millimeters.
  3. Dimension D do not include mould flash, protrusion or gate burrs. These shall not exceed 0.006" per side.
  4. Dimension E1 do not include inter-lead flash or protrusion. These shall not exceed 0.010" per side.
  5. Dimension b does not include dambar protrusion/intrusion. Allowable dambar protrusion shall be 0.004" total in excess of b dimension.

© Zarlink Semiconductor 2002 All rights reserved.					Package Code	DC
ISSUE	1	2	3		Previous package codes	Package Outline for 20 lead SOIC (0.300" Body Width)
ACN	6746	201941	213098		MP / S	
DATE	7Apr95	27Feb97	15Jul02			GPD00015
APPRD.						

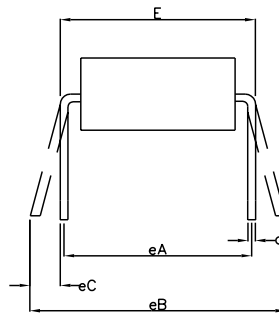
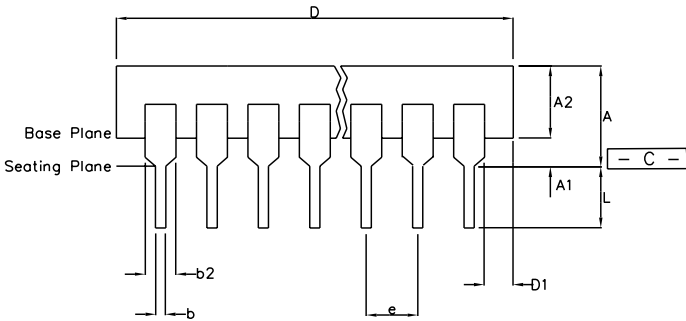
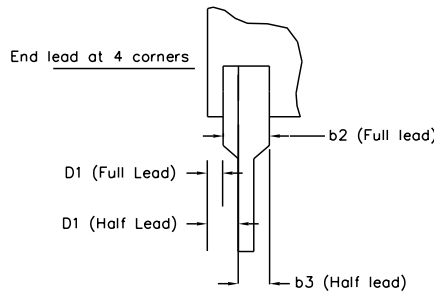
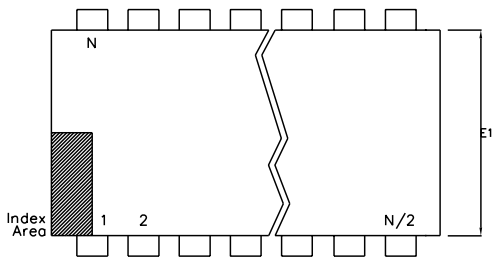

	Min mm	Max mm	Min Inches	Max Inches
A		5.33		0.210
A1	0.38		0.015	
A2	2.92	4.95	0.115	0.195
b	0.36	0.56	0.014	0.022
b2	1.14	1.78	0.045	0.070
b3	n/a	n/a	n/a	n/a
c	0.20	0.36	0.008	0.014
D	24.89	26.92	0.980	1.060
D1	0.13		0.005	
E	7.62	8.26	0.300	0.325
E1	6.10	7.11	0.240	0.280
e	2.54 BSC		0.100 BSC	
eA	7.62 BSC		0.300 BSC	
eB		10.92		0.430
eC	0.00	1.52	0.000	0.060
L	2.92	3.81	0.115	0.150
N	20		20	
Conforms to Jedec MS-001AD Issue D				

- Notes:
- Dimensions D, D1 & E1 do not include mould flash or protrusions.
  - Dimensions E & eA are measured with leads constrained to be perpendicular to datum  $\text{--- C ---}$
  - Dimensions eB & eC are measured with the leads unconstrained
  - Controlling dimensions are Inches. Millimeter conversions are not necessarily exact.
  - N is the maximum of terminal positions.

This drawing supersedes: -  
UK drawing # 418/ED/39502/005

© Zarlink Semiconductor 2002 All rights reserved.

ISSUE	1	2		
ACN	202562	213107		
DATE	9Jun97	15Jul02		
APPRD.				



Previous package codes		Package Code DA
DP / E		Package Outline for 20 lead PDIP
		GPD00347

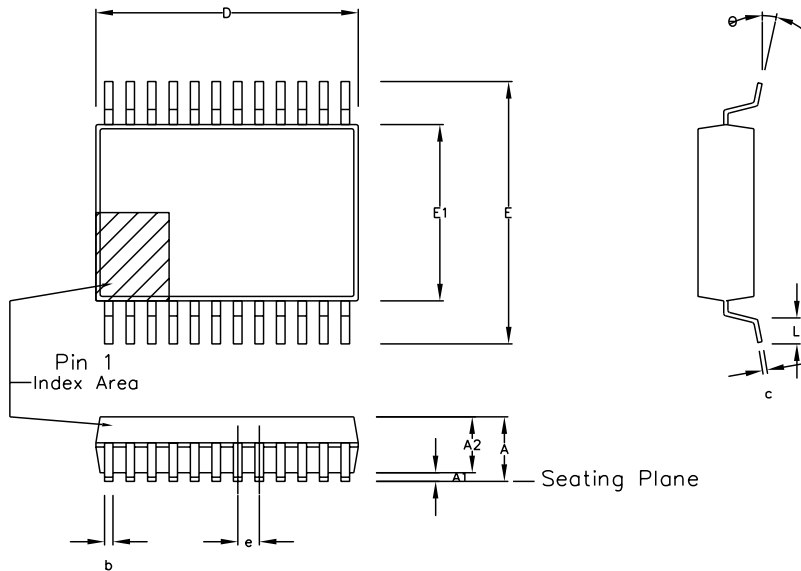

Symbol	Control Dimensions in millimetres			Altern. Dimensions in inches		
	MIN	Nominal	MAX	MIN	Nominal	MAX
A	1.70		2.00	0.067		0.079
A1	0.05		0.20	0.002		0.008
A2	1.65		1.85	0.065		0.073
D	7.90		8.50	0.311		0.335
E	7.40		8.20	0.291		0.323
E1	5.00		5.60	0.197		0.220
L	0.55		0.95	0.022		0.037
e	0.65 BSC.			0.026 BSC.		
b	0.22		0.38	0.009		0.015
c	0.09		0.25	0.004		0.010
θ	0°		8°	0°		8°
Pin features						
N	24					
Conforms to JEDEC MO-150 AG Iss. B						

This drawing supersedes: -  
418/ED/51481/003 (UK)

- Notes:
1. A visual index feature, e.g. a dot, must be located within the cross-hatched area.
  2. Controlling dimension are in millimeters.
  3. Dimensions D and E1 do not include mould flash or protrusion. Mould flash or protrusion shall not exceed 0.20 mm per side. D and E1 are maximum plastic body size dimensions including mould mismatch.
  4. Dimension b does not include dambar protrusion/intrusion. Allowable dambar protrusion shall be 0.13 mm total in excess of b dimension. Dambar intrusion shall not reduce dimension b by more than 0.07 mm.

© Zarlink Semiconductor 2002 All rights reserved.					Package Code	DD
ISSUE	1	2	3		Previous package codes	Package Outline for 24 lead SSOP (5.3mm Body Width)
ACN	201934	205233	213104		NP / N	
DATE	27Feb97	25Sep98	15Jul02			GPD00295
APPRD.						



**For more information about all Zarlink products  
visit our Web Site at  
[www.zarlink.com](http://www.zarlink.com)**

Information relating to products and services furnished herein by Zarlink Semiconductor Inc. or its subsidiaries (collectively "Zarlink") is believed to be reliable. However, Zarlink assumes no liability for errors that may appear in this publication, or for liability otherwise arising from the application or use of any such information, product or service or for any infringement of patents or other intellectual property rights owned by third parties which may result from such application or use. Neither the supply of such information or purchase of product or service conveys any license, either express or implied, under patents or other intellectual property rights owned by Zarlink or licensed from third parties by Zarlink, whatsoever. Purchasers of products are also hereby notified that the use of product in certain ways or in combination with Zarlink, or non-Zarlink furnished goods or services may infringe patents or other intellectual property rights owned by Zarlink.

This publication is issued to provide information only and (unless agreed by Zarlink in writing) may not be used, applied or reproduced for any purpose nor form part of any order or contract nor to be regarded as a representation relating to the products or services concerned. The products, their specifications, services and other information appearing in this publication are subject to change by Zarlink without notice. No warranty or guarantee express or implied is made regarding the capability, performance or suitability of any product or service. Information concerning possible methods of use is provided as a guide only and does not constitute any guarantee that such methods of use will be satisfactory in a specific piece of equipment. It is the user's responsibility to fully determine the performance and suitability of any equipment using such information and to ensure that any publication or data used is up to date and has not been superseded. Manufacturing does not necessarily include testing of all functions or parameters. These products are not suitable for use in any medical products whose failure to perform may result in significant injury or death to the user. All products and materials are sold and services provided subject to Zarlink's conditions of sale which are available on request.

Purchase of Zarlink's I<sup>2</sup>C components conveys a licence under the Philips I<sup>2</sup>C Patent rights to use these components in and I<sup>2</sup>C System, provided that the system conforms to the I<sup>2</sup>C Standard Specification as defined by Philips.

Zarlink, ZL and the Zarlink Semiconductor logo are trademarks of Zarlink Semiconductor Inc.

Copyright Zarlink Semiconductor Inc. All Rights Reserved.

**TECHNICAL DOCUMENTATION - NOT FOR RESALE**