

大容量多层陶瓷电容器

HIGH VALUE MULTILAYER CERAMIC CAPACITORS

	代码 code	温度特性 Temp.characteristics	使用温度范围 operating Temp. range
使用温度 OPERATIONG TEMP.	BJ	B	-25~+85°C
		X5R	-55~+85°C
	B7	X7R	-55~+125°C
		F	-25~+85°C
		Y5V	-30~+85°C

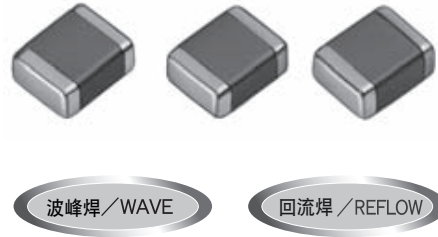

特点 FEATURES

- 使用金属镍作为内外电极，端部镀镍，因此可焊性能和耐热性能较好，器件固定牢靠，可靠性显著提高。
- 低等效串联电阻 (ESR)，吸收噪声能力强。
- 与钽或铝电解电容相比，更具有以下优点：
 - 允许较大的纹波电流
 - 相同额定电压，外型尺寸更小
 - 较高的绝缘阻抗和击穿电压，可靠性更高

- The use of Nickel(Ni) as material for both the internal and external electrodes improves the solderability and heat resistance characteristics. This almost completely eliminates migration and raises the level of reliability significantly.
- Low equivalent series resistance(ESR) provides excellent noise absorption characteristics.
- Compared to tantalum or aluminum electrolytic capacitors these ceramic capacitors offer a number of excellent features, including:
 - Higher permissible ripple current values
 - Smaller case sizes relative to rated voltage
 - Improved reliability due to higher insulation resistance and breakdown voltage.

用途 APPLICATIONS

- 一般数字电路
- 电源旁路电容器
- 液晶模块
- 液晶驱动电压线路
- LSI、IC、变换器 (输入和输出)
- 平滑电容器
- DC-DC变换器 (输入和输出)
- 开关电源 (二次侧)

- General digital circuit
- Power supply bypass capacitors
- Liquid crystal modules
- Liquid crystal drive voltage lines
- LSI, IC, converters(both for input and output)
- Smoothing capacitors
- DC-DC converters (both for input and output)
- Switching power supplies (secondary side)

型号标示法 ORDERING CODE

1	2	3	4	5	6	7	8	9	10	11
额定电压 [VDC]	系列名称	端接类型	外型尺寸 [EIA]长×宽 (mm)	温度特性代码 (%)	标称电容量 [pF]	电容量公差	产品厚度 (mm)	个别规格	包装	本公司管理记号
A 4 J 6.3 L 10 E 16 T 25 G 35 U 50	M 多层电容器	K 电镀	107 (0603) 1.6×0.8 212 (0805) 2.0×1.25 316 (1206) 3.2×1.6 325 (1210) 3.2×2.5	△F B ±30 ±10 △=空格	例 473 47,000 105 1,000,000	K ±10 % A 0.8 D ±20 % Z ±80 -20 %	K 0.45 A 0.8 D 0.85 F 1.15 G 1.25 H 1.5 L 1.6 N 1.9 Y 2.0max M 2.5	- 标准	T 卷盘带装	△ 标准品 △=空格

J M K 3 1 6 B J 1 0 6 M L - T ○

1	2	3	4	5	6	7	8	9	10	11
Rated voltage [VDC]	Series name	End termination	Dimensions (case size) (mm)	Temperature characteristics code	Nominal capacitance [pF]	Capacitance tolerances [%]	Thickness (mm)	Special code	Packaging	Internal code
A 4 J 6.3 L 10 E 16 T 25 G 35 U 50	M Multilayer Ceramic Capacitors	K Plated	107 (0603) 1.6×0.8 212 (0805) 2.0×1.25 316 (1206) 3.2×1.6 325 (1210) 3.2×2.5	△F Y5V -30~+85°C +22/-82% B 7 X7R -55~+125°C ±15% B J X5R -55~+85°C ±15% △=Blank space	example 473 47,000 105 1,000,000	K ±10 M ±20 Z ±80 -20	K 0.45 A 0.8 D 0.85 F 1.15 G 1.25 H 1.5 L 1.6 N 1.9 Y 2.0max M 2.5	- Standard products	T Tape & reel	△ Standard products △=Blank space

外型尺寸 EXTERNAL DIMENSIONS

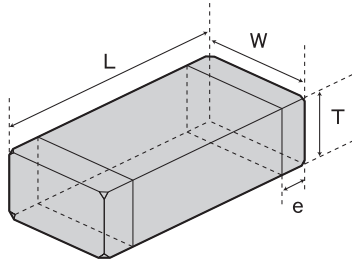

- 注: *1. ±0.15mm公差
 *2. ±0.3mm公差
 *3. ±0.2mm公差
 *4. +0.15/-0.1mm公差

Note: *1. Including dimension tolerance ±0.15mm (±0.006 inch).
 Note: *2. Including dimension tolerance ±0.3mm (±0.012 inch).
 Note: *3. Including dimension tolerance ±0.2mm (±0.008 inch).
 Note: *4. Including dimension tolerance +0.15/-0.1mm (+0.006/-0.004 inch).

类型 Type (EIA)	长 L	宽 W	厚 T	端 e
□MK107 (0603)	1.6±0.10 ^{-3,-4} (0.063±0.004)	0.8±0.10 ^{-3,-4} (0.031±0.004)	0.45±0.05 (0.018±0.002) 0.8±0.10 ^{-3,-4} (0.031±0.004)	K A (0.014±0.010)
□MK212 (0805)	2.0±0.10 ^{-1,-3} (0.079±0.004)	1.25±0.10 ^{-1,-3} (0.049±0.004)	0.45±0.05 (0.018±0.002) 0.85±0.10 (0.033±0.004) 1.25±0.10 ^{-1,-3} (0.049±0.004)	K D G (0.020±0.010)
□MK316 (1206)	3.2±0.15 ⁻³ (0.126±0.006)	1.6±0.15 ⁻³ (0.063±0.006)	0.85±0.10 (0.033±0.004) 1.15±0.10 (0.045±0.004) 1.25±0.10 (0.049±0.004)	D F G (0.020±0.010)
□MK325 (1210)	3.2±0.30 (0.126±0.012)	2.5±0.20 ⁻² (0.098±0.008)	1.6±0.20 (0.063±0.008) 0.85±0.10 (0.033±0.004) 1.15±0.10 (0.045±0.004) 1.5±0.10 (0.059±0.004) 1.9±0.20 (0.075±0.008) 1.9±0.3 (0.075±0.008)	L D F H N Y (0.024±0.012)
			2.5±0.20 ⁻² (0.098±0.008)	M

Unit:mm (inch)

电容量取值范围 AVAILABLE CAPACITANCE RANGE

电容量 μF	107										212										316										325									
	TC	B/X7R	B/X5R	X5R	F/Y5V	B/X7R	B/X5R	X5R	F/Y5V	B/X7R	B/X5R	X5R	F/Y5V	B/X7R	B/X5R	X5R	F/Y5V	B/X7R	B/X5R	X5R	F/Y5V	B/X7R	B/X5R	X5R	F/Y5V															
0.022	223	A																																						
0.033	333	A	A																																					
0.047	473	A	A																																					
0.068	683	A	A																																					
0.1	104								A																															
0.15	154	A	A																																					
0.22	224	A	A						A																															
0.33	334	A	A																																					
0.47	474	A	A	A					A	A																														
0.68	684	A	A	A																																				
1	105	A	A	A	A				A	A																														
2.2	225	A	A	A	A				A	A																														
3.3	335																																							
4.7	475																																							
6.8	685																																							
10	106																																							
22	226																																							
47	476																																							
100	107																																							

注: 图表中的字母标记为产品厚度代码。 Note: Letters in the table indicate thickness.

薄型多层陶瓷电容 Low profile Multilayer Ceramic Capacitors

电容量 μF	107										212										316										325									
	TC	B/X5R	X5R	F/Y5V	B/X7R	B/X5R	X5R	F/Y5V	B/X7R	B/X5R	X5R	F/Y5V	B/X7R	B/X5R	X5R	F/Y5V	B/X7R	B/X5R	X5R	F/Y5V	B/X7R	B/X5R	X5R	F/Y5V																
0.022	223																																							
0.033	333																																							
0.047	473																																							
0.068	683																																							
0.1	104																																							
0.22	224																																							
0.33	334																																							
0.47	474																																							
0.68	684																																							
1	105	K	K	K					D	D	D	D-K	K	K																										
2.2	225																																							
3.3	335																																							
4.7	475																																							
6.8	685																																							
10	106																																							
22	226																																							
47	476																																							

注: 图表中的字母标记为产品厚度代码。 Note: Letters in the table indicate thickness.

温度特性代码 Temp.char.Code	温度特性 Temperature characteristics					电容量公差[%] Capacitance tolerance	损耗角正切 tan δ[%]
	适用标准 Applicable standard	温度范围[°C] Temperature range	基准温度[°C] Ref. Temp.	电容量变化[%] Capacitance change			
BJ	JIS	B	-25~+85	20	±10	±10(K) ±20(M)	2.5 max.*
	EIA	X5R	-55~+85	25	±15		
B7	EIA	X7R	-55~+125	25	±15	±10(K) ±20(M)	2.5 max.*
	JIS	F	-25~+85	20	+30/-80		
F	EIA	Y5V	-30~+85	25	+22/-82	+80 -20(Z)	7.0 max.*

*: 此处数据为代表值。详情请参见型号一览表。

*: The figure indicates typical value. Please refer to PART NUMBERS table.

选件指南
Selection Guide



etc

型号一览
Part Numbers



特性图
Electrical Characteristics



包装
Packaging



可靠性
Reliability Data



使用注意事项
Precautions



■ 107 型 107TYPE

【温度特性 Temp.char. BJ:B/X5R】

额定电压 Rated Voltage	型号 Ordering code	EHS (Environmental Hazardous Substances)	标称电容量 Capacitance 〔μF〕	温度特性 Temperature characteristics	损耗角正切 tan δ Dissipation factor 〔%〕Max.	焊接方式 Soldering method R:回流焊 Reflow soldering W:波峰焊 Wave soldering	电容量公差 Capacitance tolerance	厚度 Thickness 〔mm〕 〔inch〕
35V	GMK107 BJ333□A	RoHS	0.033	B/X5R	3.5	R/W	±10% ±20%	0.8±0.1
	GMK107 BJ473□A	RoHS	0.047	B/X5R	3.5			0.8±0.1
	GMK107 BJ105□A*	RoHS	1	B/X5R	5	R		0.8±0.1
25V	TMK107 BJ223□A	RoHS	0.022	B/X5R**	2.5	R/W		0.8±0.1
	TMK107 BJ683□A	RoHS	0.068	B/X5R	3.5			0.8±0.1
	TMK107 BJ154□A	RoHS	0.15	B/X5R	3.5			0.8±0.1
	TMK107 BJ224□A	RoHS	0.22	B/X5R	3.5			0.8±0.1
	TMK107 BJ334□A	RoHS	0.33	B/X5R	3.5			0.8±0.1
	TMK107 BJ474□A*	RoHS	0.47	B/X5R	3.5	R		0.8±0.1
	TMK107 BJ105□A*	RoHS	1	B/X5R	5			0.8±0.1
16V	EMK107 BJ105□K*	RoHS	1	X5R	10	R/W	0.45±0.05	
	EMK107 BJ333□A	RoHS	0.033	B/X5R**	3.5		0.8±0.1	
	EMK107 BJ473□A	RoHS	0.047	B/X5R**	3.5		0.8±0.1	
	EMK107 BJ683□A	RoHS	0.068	B/X5R**	3.5		0.8±0.1	
	EMK107 BJ154□A*	RoHS	0.15	B/X5R**	3.5	R	0.8±0.1	
	EMK107 BJ224□A*	RoHS	0.22	B/X5R**	3.5		0.8±0.1	
	EMK107 BJ474□A	RoHS	0.47	B/X5R	3.5		0.8±0.1	
	EMK107 BJ105□A*	RoHS	1	B/X5R	5		0.8±0.1	
10V	EMK107 BJ225□A*	RoHS	2.2	B/X5R	10	R	0.8±0.1	
	LMK107 BJ105□K*	RoHS	1	B/X5R	10		0.45±0.05	
	LMK107 BJ225□K*	RoHS	2.2	X5R	10	R/W	0.45±0.05	
	LMK107 BJ334□A	RoHS	0.33	B/X5R**	3.5		0.8±0.1	
	LMK107 BJ474□A	RoHS	0.47	B/X5R**	3.5		0.8±0.1	
	LMK107 BJ684□A	RoHS	0.68	B/X5R	5		0.8±0.1	
	LMK107 BJ105□A*	RoHS	1	B/X5R**	5		0.8±0.1	
	LMK107 BJ225□A*	RoHS	2.2	B/X5R	10		0.8±0.1	
	LMK107 BJ335□A*	RoHS	3.3	X5R	10		0.8±0.1	
	LMK107 BJ475□A*	RoHS	4.7	X5R	10		0.8±0.1	
6.3V	JMK107 BJ474□K	RoHS	0.47	B/X5R	5	R	0.45±0.05	
	JMK107 BJ105□K*	RoHS	1	B/X5R	10		0.45±0.05	
	JMK107 BJ225□K*	RoHS	2.2	X5R	10		0.45±0.05	
	JMK107 BJ475MK*	RoHS	4.7	X5R	10		±20%	0.45±0.05
	JMK107 BJ225□A*	RoHS	2.2	B/X5R	10		±10%	0.8±0.1
	JMK107 BJ335□A*	RoHS	3.3	X5R	10		±20%	0.8±0.1
	JMK107 BJ475□A*	RoHS	4.7	X5R	10		0.8±0.1	
4V	JMK107 BJ106MA*	RoHS	10	X5R	10	±20%	0.8+0.15/-0.1	
	AMK107 BJ225□K*	RoHS	2.2	X5R	10	±10%	0.45±0.05	
	AMK107 BJ475MK*	RoHS	4.7	X5R	10	±20%	0.45±0.05	
	AMK107 BJ106MA*	RoHS	10	X5R	10		0.8±0.1	
	AMK107 BJ226MA*	RoHS	22	X5R	10		0.8±0.2	

**因个别规格约定，将提供X7R规格对应的说明书。

We may provide X7R for some items according to the individual specification.

【温度特性 Temp.char. B7:X7R】

额定电压 Rated Voltage	型号 Ordering code	EHS (Environmental Hazardous Substances)	标称电容量 Capacitance 〔μF〕	温度特性 Temperature characteristics	损耗角正切 tan δ Dissipation factor 〔%〕Max.	焊接方式 Soldering method R:回流焊 Reflow soldering W:波峰焊 Wave soldering	电容量公差 Capacitance tolerance	厚度 Thickness 〔mm〕 〔inch〕
25V	TMK107 B7 223□A	RoHS	0.022	X7R	2.5	R/W	±10% ±20%	0.8±0.1
	EMK107 B7 333□A	RoHS	0.033	X7R	3.5			0.8±0.1
16V	EMK107 B7 473□A	RoHS	0.047	X7R	3.5			0.8±0.1
	EMK107 B7 683□A	RoHS	0.068	X7R	3.5			0.8±0.1
	EMK107 B7 154□A*	RoHS	0.15	X7R	3.5			0.8±0.1
	EMK107 B7 224□A*	RoHS	0.22	X7R	3.5			0.8±0.1
10V	EMK107 B7 105□A*	RoHS	1	X7R	5	R		0.8±0.1
	LMK107 B7 334□A	RoHS	0.33	X7R	3.5	R/W		0.8±0.1
	LMK107 B7 474□A	RoHS	0.47	X7R	3.5	R		0.8±0.1
	LMK107 B7 105□A*	RoHS	1	X7R	5			0.8±0.1

请在型号的□中指定电容量公差代码。

□ Please specify the capacitance tolerance code.

* 高温负载试验电压为额定电压的 1.5 倍。

* Test Voltage of Loading at high temperature test is 1.5 time of the rated voltage.

型号一览 PART NUMBERS

【温度特性 Temp.char. F:F/Y5V】

额定电压 Rated Voltage	型号 Ordering code		EHS (Environmental Hazardous Substances)	标称电容量 Capacitance 〔 μ F〕	温度特性 Temperature characteristics	损耗角正切 $\tan \delta$ Dissipation factor 〔%〕Max.	焊接方式 Soldering method R:回流焊 Reflow soldering W:波峰焊 Wave soldering	电容量公差 Capacitance tolerance	厚度 Thickness 〔mm〕 〔inch〕
50V	UMK107 F104ZA		RoHS	0.1	F/Y5V	7	R/W	+80% -20%	0.8±0.1
25V	TMK107 F474ZA		RoHS	0.47	F/Y5V	7			0.8±0.1
	EMK107 F224ZA		RoHS	0.22	F/Y5V	7			0.8±0.1
16V	EMK107 F474ZA		RoHS	0.47	F/Y5V	7	R		0.8±0.1
	EMK107 F105ZA		RoHS	1	F/Y5V	16			0.8±0.1
	EMK107 F225ZA		RoHS	2.2	F/Y5V	16			0.8±0.1
10V	LMK107 F105ZA		RoHS	1	F/Y5V	16			0.8±0.1
	LMK107 F225ZA		RoHS	2.2	F/Y5V	16			0.8±0.1

型号一览 PART NUMBERS

■ 212 型 212TYPE

【温度特性 Temp.char. BJ:B/X5R】

额定电压 Rated Voltage	型号 Ordering code	EHS (Environmental Hazardous Substances)	标称电容量 Capacitance [μ F]	温度特性 Temperature characteristics	损耗角正切 $\tan \delta$ Dissipation factor [%] Max.	焊接方式 Soldering method R:回流焊 Reflow soldering W:波峰焊 Wave soldering	电容量公差 Capacitance tolerance	厚度 Thickness [mm] (inch)
50V	UMK212 BJ223□D	RoHS	0.022	B/X5R**	2.5	R/W	±10% ±20%	0.85±0.1
	UMK212 BJ333□D	RoHS	0.033	B/X5R**	2.5			0.85±0.1
	UMK212 BJ473□G	RoHS	0.047	B/X5R**	3.5			1.25±0.1
	UMK212 BJ683□G	RoHS	0.068	B/X5R**	3.5			1.25±0.1
	UMK212 BJ104□G	RoHS	0.1	B/X5R**	3.5			1.25±0.1
	UMK212 BJ154□G	RoHS	0.15	B/X5R**	3.5			1.25±0.1
	UMK212 BJ224□G*	RoHS	0.22	B/X5R**	3.5			1.25±0.1
35V	UMK212 BJ474□G*	RoHS	0.47	B/X5R	3.5	1.25±0.1		
	GMK212 BJ334□G	RoHS	0.33	B/X5R**	3.5	1.25±0.1		
	GMK212 BJ474□G	RoHS	0.47	B/X5R	3.5	1.25±0.1		
25V	GMK212 BJ105□G*	RoHS	1	B/X5R**	3.5	1.25±0.1		
	TMK212 BJ473□D	RoHS	0.047	B/X5R**	2.5	0.85±0.1		
	TMK212 BJ683□D	RoHS	0.068	B/X5R**	2.5	0.85±0.1		
	TMK212 BJ474□D	RoHS	0.47	B/X5R	3.5	0.85±0.1		
	TMK212 BJ105□D	RoHS	1	B/X5R	5	0.85±0.1		
	TMK212 BJ105□G	RoHS	1	B/X5R	5	1.25±0.1		
	TMK212 BJ225□G*	RoHS	2.2	B/X5R	5	1.25±0.1		
16V	TMK212 BJ475□G*	RoHS	4.7	X5R	10	1.25±0.15		
	EMK212 BJ105□K*	RoHS	1	B/X5R	5	0.45±0.05		
	EMK212 BJ474□D	RoHS	0.47	B/X5R**	3.5	0.85±0.1		
	EMK212 BJ684□D	RoHS	0.68	B/X5R**	3.5	0.85±0.1		
	EMK212 BJ105□D	RoHS	1	B/X5R	5	0.85±0.1		
	EMK212 BJ225□D	RoHS	2.2	B/X5R	5	0.85±0.1		
	EMK212 BJ475□D*	RoHS	4.7	B/X5R	10	0.85±0.1		
	EMK212 BJ684□G	RoHS	0.68	B/X5R**	3.5	1.25±0.1		
	EMK212 BJ105□G	RoHS	1	B/X5R**	3.5	1.25±0.1		
10V	EMK212 BJ225□G	RoHS	2.2	B/X5R**	5	1.25±0.1		
	EMK212 BJ475□G*	RoHS	4.7	B/X5R	5	1.25±0.15		
	EMK212 BJ106□G*	RoHS	10	B/X5R	10	1.25±0.15		
	LМК212 BJ105□K	RoHS	1	B/X5R	5	0.45±0.05		
	LМК212 BJ475□K*	RoHS	4.7	X5R	10	0.45±0.05		
	LМК212 BJ105□D	RoHS	1	B/X5R**	3.5	0.85±0.1		
	LМК212 BJ225□D*	RoHS	2.2	B/X5R	5	0.85±0.1		
	LМК212 BJ475□D*	RoHS	4.7	B/X5R	10	0.85±0.1		
	LМК212 BJ106□D*	RoHS	10	X5R	10	0.85±0.1		
	LМК212 BJ105□G	RoHS	1	B/X5R**	3.5	1.25±0.1		
	LМК212 BJ225□G	RoHS	2.2	B/X5R**	5	1.25±0.1		
	LМК212 BJ335□G	RoHS	3.3	B/X5R**	5	1.25±0.1		
	LМК212 BJ475□G	RoHS	4.7	B/X5R	5	1.25±0.15		
6.3V	LМК212 BJ106□G	RoHS	10	X5R	10	1.25±0.15		
	LМК212 BJ226MG	RoHS	22	X5R	10	±20% 1.25±0.2		
	JMK212 BJ105□K	RoHS	1	B/X5R	5	±10% 0.45±0.05		
	JMK212 BJ475□K*	RoHS	4.7	X5R	10	±20% 0.45±0.05		
	JMK212 BJ106MK*	RoHS	10	X5R	10	±20% 0.45±0.05		
	JMK212 BJ475□D	RoHS	4.7	X5R	10	±10% 0.85±0.1		
	JMK212 BJ106□D*	RoHS	10	X5R	10	±20% 0.85±0.1		
	JMK212 BJ226MD*	RoHS	22	X5R	10	±20% 0.85±0.1		
	JMK212 BJ475□G	RoHS	4.7	B/X5R	5	±10% 1.25±0.15		
	JMK212 BJ106□G	RoHS	10	X5R	10	±20% 1.25±0.15		
	JMK212 BJ226MG*	RoHS	22	X5R	10	±20% 1.25±0.15		
4V	JMK212 BJ476MG*	RoHS	47	X5R	10	±20% 1.25±0.2		
	AMK212 BJ226MD*	RoHS	22	X5R	10	±20% 0.85±0.1		

请在型号的□中指定电容量公差代码。

* 高温负载试验电压为额定电压的 1.5 倍。

** 因个别规格约定，将提供 X7R 规格对应的说明书。

□ Please specify the capacitance tolerance code.

* Test Voltage of Loading at high temperature test is 1.5 time of the rated voltage.

** We may provide X7R for some items according to the individual specification.

型号一览 PART NUMBERS

【温度特性 Temp.char. B7:X7R】

额定电压 Rated Voltage	型号 Ordering code	EHS (Environmental Hazardous Substances)	标称电容量 Capacitance 〔μF〕	温度特性 Temperature characteristics	损耗角正切 tan δ Dissipation factor 〔%〕Max.	焊接方式 Soldering method R:回流焊 Reflow soldering W:波峰焊 Wave soldering	电容量公差 Capacitance tolerance	厚度 Thickness 〔mm〕 〔inch〕
50V	UMK212 B7 223□D	RoHS	0.022	X7R	2.5	R/W	±10% ±20%	0.85±0.1
	UMK212 B7 333□D	RoHS	0.033	X7R	2.5			0.85±0.1
	UMK212 B7 473□G	RoHS	0.047	X7R	3.5			1.25±0.1
	UMK212 B7 683□G	RoHS	0.068	X7R	3.5			1.25±0.1
	UMK212 B7 104□G	RoHS	0.1	X7R	3.5			1.25±0.1
	UMK212 B7 154□G	RoHS	0.15	X7R	3.5			1.25±0.1
35V	UMK212 B7 224□G*	RoHS	0.22	X7R	3.5	R		1.25±0.1
	GMK212 B7 334□G	RoHS	0.33	X7R	3.5			1.25±0.1
25V	GMK212 B7 105□G*	RoHS	1	X7R	3.5	R/W		1.25±0.1
	TMK212 B7 473□D	RoHS	0.047	X7R	2.5			0.85±0.1
	TMK212 B7 683□D	RoHS	0.068	X7R	2.5			0.85±0.1
16V	TMK212 B7 105□G*	RoHS	1	X7R	5	R/W		1.25±0.1
	EMK212 B7 474□D	RoHS	0.47	X7R	3.5		0.85±0.1	
	EMK212 B7 684□D	RoHS	0.68	X7R	3.5		0.85±0.1	
	EMK212 B7 105□D	RoHS	1	X7R	5		0.85±0.1	
	EMK212 B7 684□G	RoHS	0.68	X7R	3.5		1.25±0.1	
	EMK212 B7 105□G	RoHS	1	X7R	3.5		1.25±0.1	
10V	EMK212 B7 225□G*	RoHS	2.2	X7R	10	R	1.25±0.1	
	LMK212 B7 105□D	RoHS	1	X7R	3.5		0.85±0.1	
	LMK212 B7 105□G	RoHS	1	X7R	3.5		1.25±0.1	
	LMK212 B7 225□G	RoHS	2.2	X7R	5		1.25±0.1	
	LMK212 B7 335□G	RoHS	3.3	X7R	5	R	1.25±0.1	

【温度特性 Temp.char. F:F/Y5V】

额定电压 Rated Voltage	型号 Ordering code	EHS (Environmental Hazardous Substances)	标称电容量 Capacitance 〔μF〕	温度特性 Temperature characteristics	损耗角正切 tan δ Dissipation factor 〔%〕Max.	焊接方式 Soldering method R:回流焊 Reflow soldering W:波峰焊 Wave soldering	电容量公差 Capacitance tolerance	厚度 Thickness 〔mm〕 〔inch〕
50V	UMK212 F224ZD	RoHS	0.22	F/Y5V	7	R/W	+80% -20%	0.85±0.1
	UMK212 F474ZG	RoHS	0.47	F/Y5V	7			1.25±0.1
	UMK212 F105ZG	RoHS	1	F/Y5V	7			1.25±0.1
16V	EMK212 F225ZG	RoHS	2.2	F/Y5V	7	R		1.25±0.1
10V	LMK212 F225ZD	RoHS	2.2	F/Y5V	9			0.85±0.1
	LMK212 F475ZG	RoHS	4.7	F/Y5V	9			1.25±0.1
	LMK212 F106ZG	RoHS	10	F/Y5V	16	1.25±0.1		
6.3V	JMK212 F475ZD	RoHS	4.7	F/Y5V	16	R	0.85±0.1	
	JMK212 F106ZG	RoHS	10	F/Y5V	16		1.25±0.1	

请在型号的□中指定电容量公差代码。

* 高温负载试验电压为额定电压的 1.5 倍。

□ Please specify the capacitance tolerance code.

* Test Voltage of Loading at high temperature test is 1.5 time of the rated voltage.

型号一览 PART NUMBERS

■ 316 型 316TYPE

【温度特性 Temp.char. BJ:B/X5R】

额定电压 Rated Voltage	型号 Ordering code	EHS (Environmental Hazardous Substances)	标称电容量 Capacitance 〔μF〕	温度特性 Temperature characteristics	损耗角正切 tan δ Dissipation factor 〔%〕Max.	焊接方式 Soldering method R:回流焊 Reflow soldering W:波峰焊 Wave soldering	电容量公差 Capacitance tolerance	厚度 Thickness 〔mm〕 〔inch〕
50V	UMK316 BJ224□L	RoHS	0.22	B/X5R**	2.5	R/W	±10% ±20%	1.6±0.2
	UMK316 BJ474□L	RoHS	0.47	B/X5R**	3.5			1.6±0.2
	UMK316 BJ475□L*	RoHS	4.7	X5R	10	R		1.6±0.2
35V	GMK316 BJ684□L	RoHS	0.68	B/X5R**	3.5	R/W		1.6±0.2
	GMK316 BJ105□L	RoHS	1	B/X5R**	3.5	R/W		1.6±0.2
25V	TMK316 BJ105□D	RoHS	1	B/X5R	3.5	R		0.85±0.1
	TMK316 BJ225□D*	RoHS	2.2	B/X5R	3.5			0.85±0.1
	TMK316 BJ224□F	RoHS	0.22	B/X5R**	2.5	R/W		1.15±0.1
	TMK316 BJ334□F	RoHS	0.33	B/X5R**	2.5			1.15±0.1
	TMK316 BJ225□L	RoHS	2.2	B/X5R**	3.5	R		1.6±0.2
	TMK316 BJ335□L	RoHS	3.3	B/X5R	3.5		1.6±0.2	
	TMK316 BJ475□L*	RoHS	4.7	B/X5R	5		1.6±0.2	
	TMK316 BJ106□L*	RoHS	10	B/X5R	5		1.6±0.2	
16V	EMK316 BJ225□D	RoHS	2.2	B/X5R	3.5	R/W	0.85±0.1	
	EMK316 BJ106□D*	RoHS	10	X5R	10		0.85±0.1	
	EMK316 BJ684□F	RoHS	0.68	B/X5R**	3.5	R/W	1.15±0.1	
	EMK316 BJ105□F	RoHS	1	B/X5R**	3.5		1.15±0.1	
	EMK316 BJ106□F*	RoHS	10	X5R	10	R	1.15±0.1	
	EMK316 BJ225□L	RoHS	2.2	B/X5R**	3.5	R/W	1.6±0.2	
	EMK316 BJ335□L	RoHS	3.3	B/X5R**	3.5	R	1.6±0.2	
	EMK316 BJ475□L	RoHS	4.7	B/X5R	5		1.6±0.2	
EMK316 BJ106□L*	RoHS	10	B/X5R	5	1.6±0.2			
EMK316 BJ226ML*	RoHS	22	B/X5R	10	±20%		1.6±0.2	
10V	LMK316 BJ475□D	RoHS	4.7	B/X5R	5	R	±10%	0.85±0.1
	LMK316 BJ106□D	RoHS	10	B/X5R	10		±20%	0.85±0.1
	LMK316 BJ226MD*	RoHS	22	X5R	10		±20%	0.85±0.1
	LMK316 BJ335□L	RoHS	3.3	B/X5R**	3.5		±10%	1.6±0.2
	LMK316 BJ475□L	RoHS	4.7	B/X5R**	5		±20%	1.6±0.2
	LMK316 BJ106□L	RoHS	10	B/X5R	5		±20%	1.6±0.2
	LMK316 BJ226ML*	RoHS	22	B/X5R	10		±20%	1.6±0.2
LMK316 BJ476ML*	RoHS	47	X5R	10	±20%		1.6±0.2	
6.3V	JMK316 BJ106□D	RoHS	10	B/X5R	10		±10% ±20%	0.85±0.1
	JMK316 BJ226MD*	RoHS	22	X5R	10			0.85±0.1
	JMK316 BJ476MD*	RoHS	47	X5R	10	0.85±0.1		
	JMK316 BJ685□F	RoHS	6.8	B/X5R	10	±10%	1.15±0.1	
	JMK316 BJ106□L	RoHS	10	B/X5R**	5	±20%	1.6±0.2	
	JMK316 BJ226□L	RoHS	22	X5R	10	±20%	1.6±0.2	
4V	JMK316 BJ476ML	RoHS	47	X5R	10	±20%	1.6±0.2	
	JMK316 BJ107ML*	RoHS	100	X5R	10		1.6±0.2	
	AMK316 BJ107ML*	RoHS	100	X5R	10		1.6±0.2	

** 因个别规格约定，将提供 X7R 规格对应的说明书。

**We may provide X7R for some items according to the individual specification

【温度特性 Temp.char. B7:X7R】

额定电压 Rated Voltage	型号 Ordering code	EHS (Environmental Hazardous Substances)	标称电容量 Capacitance 〔μF〕	温度特性 Temperature characteristics	损耗角正切 tan δ Dissipation factor 〔%〕Max.	焊接方式 Soldering method R:回流焊 Reflow soldering W:波峰焊 Wave soldering	电容量公差 Capacitance tolerance	厚度 Thickness 〔mm〕 〔inch〕	
50V	UMK316 B7 224□L	RoHS	0.22	X7R	2.5	R/W	±10% ±20%	1.6±0.2	
	UMK316 B7 474□L	RoHS	0.47	X7R	3.5			1.6±0.2	
35V	GMK316 B7 684□L	RoHS	0.68	X7R	3.5			1.6±0.2	
	GMK316 B7 105□L	RoHS	1	X7R	3.5			1.6±0.2	
25V	TMK316 B7 224□F	RoHS	0.22	X7R	2.5			R	1.15±0.1
	TMK316 B7 334□F	RoHS	0.33	X7R	2.5				1.15±0.1
16V	TMK316 B7 225□L	RoHS	2.2	X7R	3.5	R		1.6±0.2	
	EMK316 B7 684□F	RoHS	0.68	X7R	3.5			1.15±0.1	
	EMK316 B7 105□F	RoHS	1	X7R	3.5	R/W		1.15±0.1	
	EMK316 B7 225□L	RoHS	2.2	X7R	3.5			1.6±0.2	
10V	EMK316 B7 335□L	RoHS	3.3	X7R	3.5	R	1.6±0.2		
	LMK316 B7 335□L	RoHS	3.3	X7R	3.5		1.6±0.2		
	LMK316 B7 475□L	RoHS	4.7	X7R	5		1.6±0.2		
6.3V	LMK316 B7 106□L*	RoHS	10	X7R	5	±20%	1.6±0.2		
	JMK316 B7 106□L	RoHS	10	X7R	5		1.6±0.2		

请在型号的□中指定电容量公差代码。

□ Please specify the capacitance tolerance code.

* 高温负载试验电压为额定电压的 1.5 倍。

* Test Voltage of Loading at high temperature test is 1.5 time of the rated voltage.

型号一览 PART NUMBERS

【温度特性 Temp.char. F:F/Y5V】

额定电压 Rated Voltage	型号 Ordering code	EHS (Environmental Hazardous Substances)	标称电容量 Capacitance [μF]	温度特性 Temperature characteristics	损耗角正切 tan δ Dissipation factor [%] Max.	焊接方式 Soldering method R:回流焊 Reflow soldering W:波峰焊 Wave soldering	电容量公差 Capacitance tolerance	厚度 Thickness [mm] (inch)
50V	UMK316 F225ZG	RoHS	2.2	F/Y5V	7	R/W	+80% -20%	1.25±0.1
35V	GMK316 F475ZG	RoHS	4.7	F/Y5V	7	R		1.25±0.1
	GMK316 F106ZL	RoHS	10	F/Y5V	9			1.6±0.2
25V	TMK316 F106ZL	RoHS	10	F/Y5V	9			1.6±0.2
16V	EMK316 F106ZL	RoHS	10	F/Y5V	9			1.6±0.2
	LМК316 F475ZD	RoHS	4.7	F/Y5V	9			0.85±0.1
	LМК316 F106ZF	RoHS	10	F/Y5V	16			1.15±0.1
10V	LМК316 F226ZL	RoHS	22	F/Y5V	16			1.6±0.2
	JMK316 F106ZD	RoHS	10	F/Y5V	16			0.85±0.1

■ 325型 325TYPE

【温度特性 Temp.char. BJ:B/X5R】

额定电压 Rated Voltage	型号 Ordering code	EHS (Environmental Hazardous Substances)	标称电容量 Capacitance [μF]	温度特性 Temperature characteristics	损耗角正切 tan δ Dissipation factor [%] Max.	焊接方式 Soldering method R:回流焊 Reflow soldering W:波峰焊 Wave soldering	电容量公差 Capacitance tolerance	厚度 Thickness [mm] (inch)
50V	UMK325 BJ105□H	RoHS	1	B/X5R**	3.5	R/W	±10% ±20%	1.5±0.1
	UMK325 BJ475MM*	RoHS	4.7	X5R	10	R		2.5±0.2
	UMK325 BJ106MM*	RoHS	10	X5R	10			2.5±0.2
35V	GMK325 BJ225MN	RoHS	2.2	B/X5R	3.5			1.9±0.2
	GMK325 BJ475MN*	RoHS	4.7	X5R	10			1.9±0.2
	GMK325 BJ106MN*	RoHS	10	B/X5R	5			1.9±0.2
25V	TMK325 BJ106MD*	RoHS	10	B/X5R	5			0.85±0.1
	TMK325 BJ225MH	RoHS	2.2	B/X5R**	3.5			1.5±0.1
	TMK325 BJ335MN	RoHS	3.3	B/X5R**	3.5			1.9±0.2
	TMK325 BJ475MN*	RoHS	4.7	B/X5R**	3.5			1.9±0.2
	TMK325 BJ106MN	RoHS	10	B/X5R	5		1.9±0.2	
	TMK325 BJ106MM*	RoHS	10	B/X5R	3.5	2.5±0.2		
16V	EMK325 BJ106MD*	RoHS	10	B/X5R	5	0.85±0.1		
	EMK325 BJ226MD*	RoHS	22	B/X5R	10	0.85±0.1		
	EMK325 BJ475MN	RoHS	4.7	B/X5R**	3.5	1.9±0.2		
	EMK325 BJ106MN	RoHS	10	B/X5R	3.5	1.9±0.2		
	EMK325 BJ226MM*	RoHS	22	B/X5R	5	2.5±0.2		
	EMK325 BJ476MM*	RoHS	47	X5R	10	2.5±0.2		
10V	LМК325 BJ335MD	RoHS	3.3	B/X5R	3.5	0.85±0.1		
	LМК325 BJ475MD	RoHS	4.7	B/X5R	5	0.85±0.1		
	LМК325 BJ106MD*	RoHS	10	B/X5R	5	0.85±0.1		
	LМК325 BJ226MY*	RoHS	22	B/X5R	5	1.9+0.1/-0.2		
	LМК325 BJ106MN	RoHS	10	B/X5R**	3.5	1.9±0.2		
	LМК325 BJ226MM	RoHS	22	B/X5R	5	2.5±0.2		
	LМК325 BJ476MM*	RoHS	47	X5R	10	2.5±0.2		
	LМК325 BJ107MM*	RoHS	100	X5R	10	2.5±0.3		
6.3V	JMK325 BJ226MY	RoHS	22	X5R	5	1.9+0.1/-0.2		
	JMK325 BJ107MY*	RoHS	100	X5R	10	1.9+0.1/-0.2		
	JMK325 BJ476MN*	RoHS	47	X5R	10	1.9±0.2		
	JMK325 BJ476MM*	RoHS	47	X5R	10	2.5±0.2		
	JMK325 BJ107MM*	RoHS	100	X5R	10	2.5±0.3		

请在型号的□中指定电容量公差代码。

* 高温负载试验电压为额定电压的 1.5 倍。

** 因个别规格约定，将提供 X7R 规格对应的说明书。

□ Please specify the capacitance tolerance code.

* Test Voltage of Loading at high temperature test is 1.5 time of the rated voltage.

** We may provide X7R for some items according to the individual specification.

型号一览 PART NUMBERS

【温度特性 Temp.char. B7:X7R】

额定电压 Rated Voltage	型号 Ordering code		EHS (Environmental Hazardous Substances)	标称电容量 Capacitance [μ F]	温度特性 Temperature characteristics	损耗角正切 $\tan \delta$ Dissipation factor [%] Max.	焊接方式 Soldering method R:回流焊 Reflow soldering W:波峰焊 Wave soldering	电容量公差 Capacitance tolerance	厚度 Thickness [mm] (inch)
50V	UMK325 B7105□H		RoHS	1	X7R	3.5	R/W	$\pm 10\%$ $\pm 20\%$	1.5 \pm 0.1
25V	TMK325 B7225MH		RoHS	2.2	X7R	3.5	R	$\pm 20\%$	1.5 \pm 0.1
	TMK325 B7335MN		RoHS	3.3	X7R	3.5			1.9 \pm 0.2
	TMK325 B7475MN*		RoHS	4.7	X7R	3.5			1.9 \pm 0.2
	TMK325 B7106MN*		RoHS	10	X7R	5			1.9 \pm 0.2
16V	EMK325 B7475MN		RoHS	4.7	X7R	3.5		1.9 \pm 0.2	
10V	LMK325 B7106MN		RoHS	10	X7R	3.5		1.9 \pm 0.2	

【温度特性 Temp.char. F:F/Y5V】

额定电压 Rated Voltage	型号 Ordering code		EHS (Environmental Hazardous Substances)	标称电容量 Capacitance [μ F]	温度特性 Temperature characteristics	损耗角正切 $\tan \delta$ Dissipation factor [%] Max.	焊接方式 Soldering method R:回流焊 Reflow soldering W:波峰焊 Wave soldering	电容量公差 Capacitance tolerance	厚度 Thickness [mm] (inch)
50V	UMK325 F475ZH		RoHS	4.7	F/Y5V	7	R	$+80\%$ -20%	1.5 \pm 0.1
35V	GMK325 F106ZH		RoHS	10	F/Y5V	7			1.5 \pm 0.1
16V	EMK325 F226ZN		RoHS	22	F/Y5V	16			1.9 \pm 0.2
10V	LMK325 F106ZF		RoHS	10	F/Y5V	16			1.15 \pm 0.1
	LMK325 F226ZN		RoHS	22	F/Y5V	16			1.9 \pm 0.2
6.3V	JMK325 F476ZN		RoHS	47	F/Y5V	16			1.9 \pm 0.2

请在型号的□中指定电容量公差代码。

Please specify the capacitance tolerance code.

* 高温负载试验电压为额定电压的 1.5 倍。

* Test Voltage of Loading at high temperature test is 1.5 time of the rated voltage.

阻抗、ESR—频率特性例 Example of Impedance ESR vs. Frequency characteristics

· 太阳诱电多层陶瓷电容器例 (Taiyo Yuden multilayer ceramic capacitor)

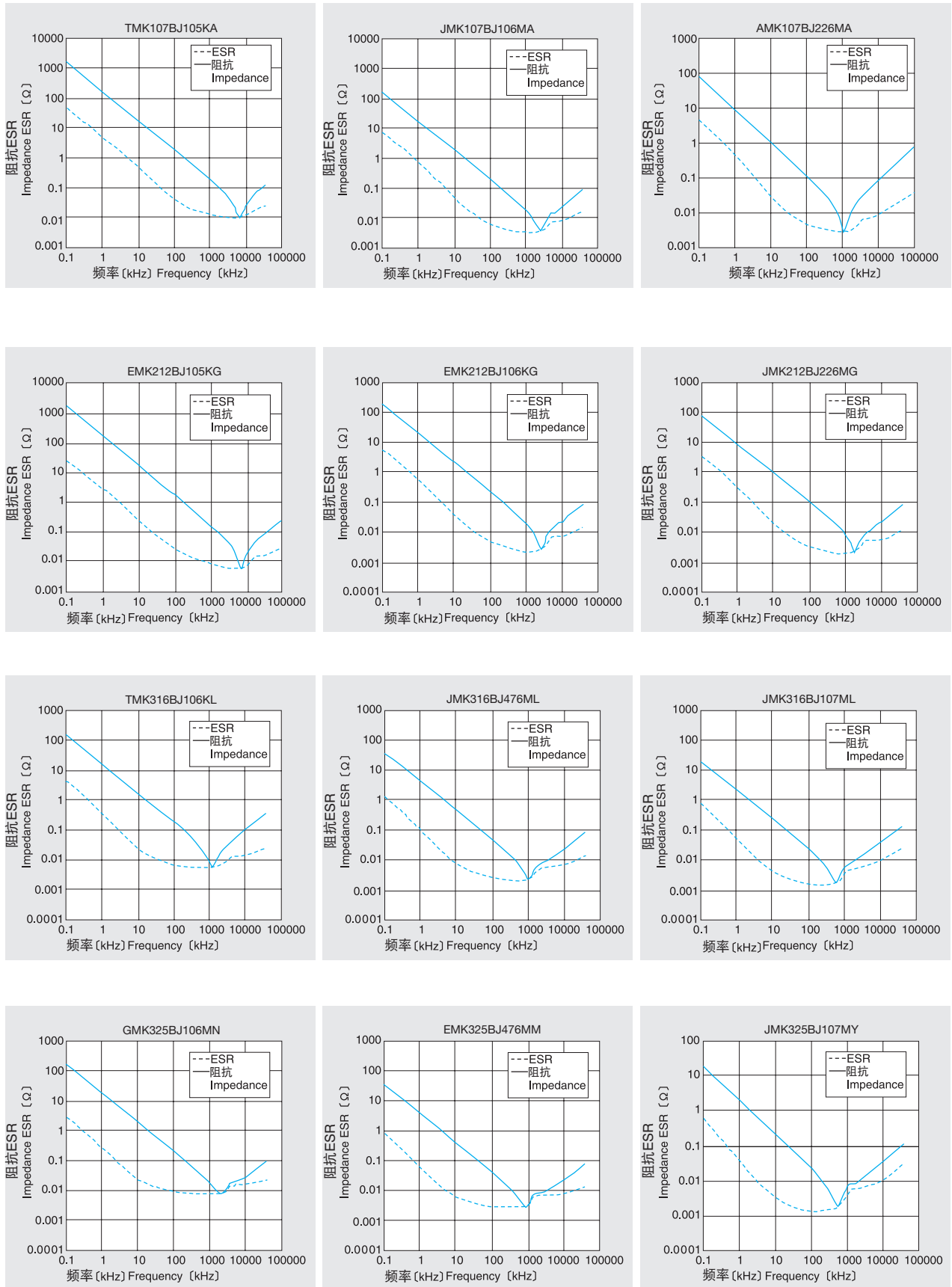

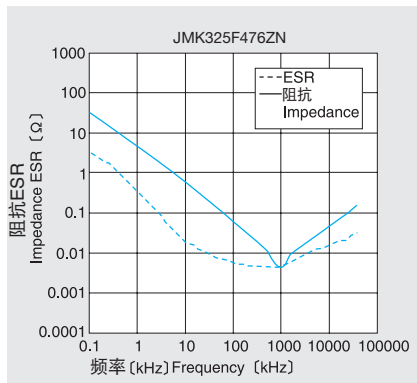
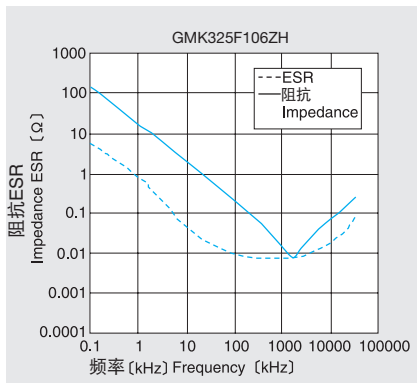
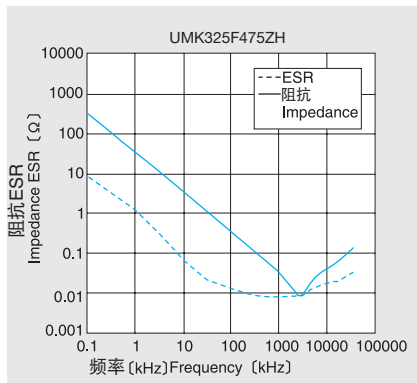
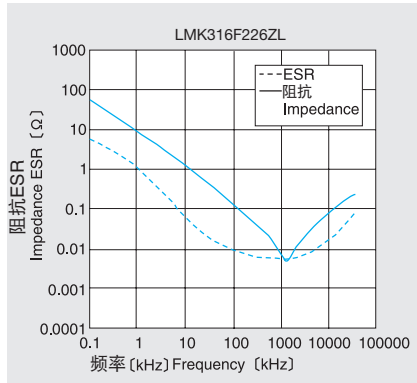
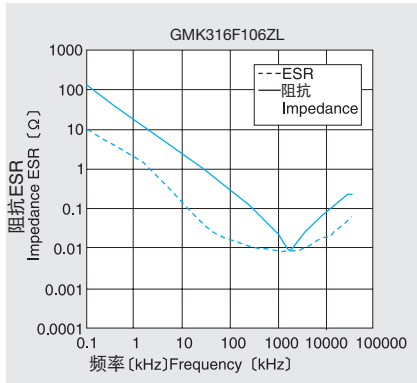
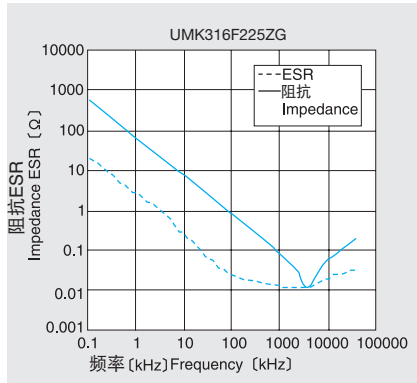
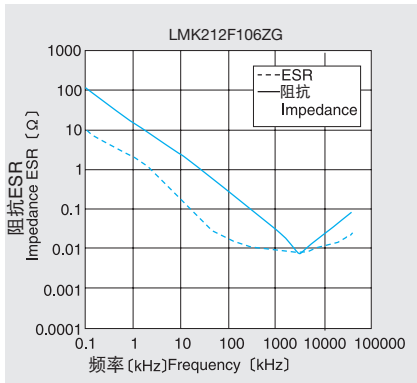
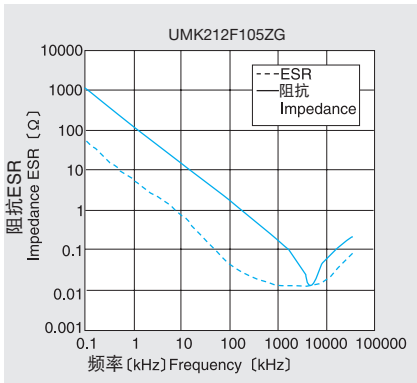
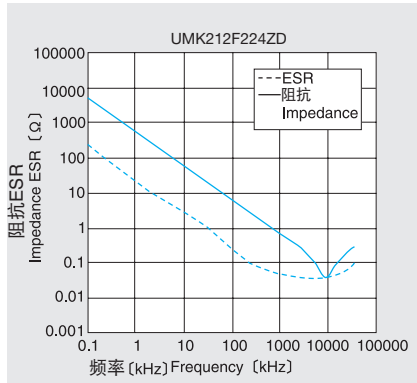
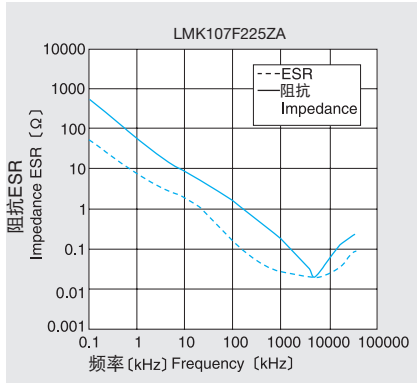
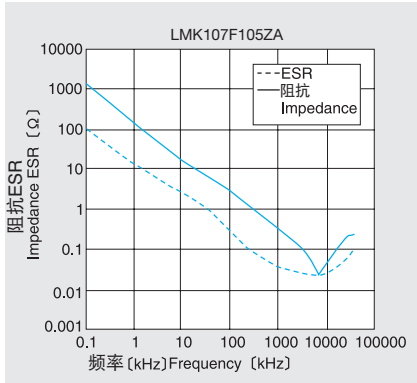
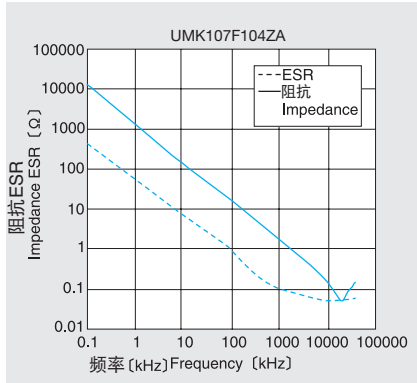

标准多层陶瓷电容器

(1类: 温度补偿用)

STANDARD MULTILAYER CERAMIC CAPACITORS

(CLASS1: TEMPERATURE COMPENSATING DIELECTRIC TYPE)

使用温度 OPERATING TEMP. $-55 \sim +125^{\circ}\text{C}$



波峰焊 / WAVE*

回流焊 / REFLOW

* 不包括042型, 063型, 105型

* Except for 042TYPE, 063TYPE, 105TYPE

特点 FEATURES

- 提高安装密度。
- 多层块状结构, 可靠性更高。
- 标准外型尺寸的电容器, 可提供更大的电容量范围。

- Improve Higher Mounting Densities.
- Multilayer block structure provides higher reliability
- A wide range of capacitance values available in standard case sizes.

用途 APPLICATIONS

- 一般电子设备
- 通讯设备 (手机、PHS、无绳电话等)

- General electronic equipment
- Communication equipment (cellular phone, PHS, other wireless applications, etc.)

型号标示法 ORDERING CODE

1 额定电压 [VDC]	4 外型尺寸 (EIA) 长×宽 (mm)	6 标称电容量 [pF]	7 电容量公差	9 个别规格
E 16 T 25 U 50	042 (01005) 0.4×0.2 063 (0201) 0.6×0.3 105 (0402) 1.0×0.5 107 (0603) 1.6×0.8	例 0R5 0.5 010 1 100 10 ※R=小数点	C ± 0.25 pF D ± 0.5 pF F ± 1 pF J ± 5 % K ± 10 %	- 标准品
2 系列名称	5 温度特性 [ppm/°C]	8 产品厚度 [mm]	10 包装	11 本公司管理记号
M 多层电容器	C□ 0: CG, CH, CJ, CK R□ -220: RH S□ -330: SH, SJ, SK G ± 30 T□ -470: TJ, TK H ± 60 U□ -750: UJ, UK J ± 120 S L +350~-1000 K ± 250 □=公差	C 0.2 P 0.3 V 0.5 W 0.5 Z 0.8	F 带装 (2mm间距·178φ) T 带装 (4mm间距·178φ)	△ 标准品 △=空格
3 端接类型				
K 电镀				

U M K 1 0 5 C H 1 0 1 J V - F ○

1 2 3 4 5 6 7 8 9 10 11

1 Rated voltage [VDC]	4 Dimensions (case size) [EIA] L×W [mm]	6 Nominal Capacitance [pF]	7 Capacitance Tolerance	9 Special code
E 16 T 25 U 50	042 (01005) 0.4×0.2 063 (0201) 0.6×0.3 105 (0402) 1.0×0.5 107 (0603) 1.6×0.8	example 0R5 0.5 010 1 100 10 *R=decimal point	C ± 0.25 pF D ± 0.5 pF F ± 1 pF J ± 5 % K ± 10 %	- Standard Products
2 Series name	5 Temperature characteristics [ppm/°C]	8 Thickness [mm]	10 Packaging	11 Internal code
M Multilayer ceramic capacitor	C□ 0: CG, CH, CJ, CK (C0G, C0H, C0J, C0K) R□ -220: RH (R2H) S□ -330: SH, SJ, SK (S2H, S2J, S2K) G ± 30 T□ -470: TJ, TK H ± 60 U□ -750: UJ, UK J ± 120 (U2J, U2K) S L +350~-1000 K ± 250 □=Tolerance	C 0.2 P 0.3 V 0.5 W 0.5 Z 0.8	F Tape (2mm pitch·178φ) T Tape (4mm pitch·178φ)	△ Standard Products △=Blank space
3 End termination				
K Plated				

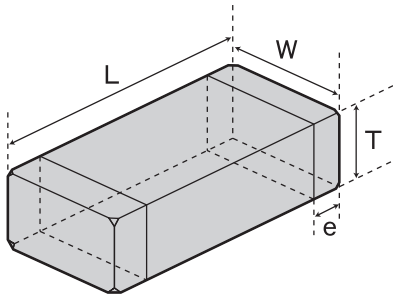

型号 Type (EIA)	长 L	宽 W	厚 T	端 e
□MK042 (01005)	0.4±0.02 (0.016±0.001)	0.2±0.02 (0.008±0.001)	0.2±0.02 (0.008±0.001)	C (0.004±0.001)
□MK063 (0201)	0.6±0.03 (0.024±0.001)	0.3±0.03 (0.012±0.001)	0.3±0.03 (0.012±0.001)	P (0.006±0.002)
□MK105 (0402)	1.0±0.05 (0.039±0.002)	0.5±0.05 (0.020±0.002)	0.5±0.05 (0.020±0.002)	W, V (0.010±0.004)
□MK107 (0603)	1.6±0.10 (0.063±0.004)	0.8±0.10 (0.031±0.004)	0.8±0.10 (0.031±0.004)	Z (0.014±0.010)

Unit : mm (inch)

电容量取值范围 AVAILABLE CAPACITANCE RANGE

Type	042	063	105						107					
Temp.char.	C	C	U	R	S	T	U	C	SL	C	PT	RS	U	SL
WV	16V	25V	16V			50V			50V					
[pF]	[pF 3digits]													
0.5	0R5													
1	010													
1.5	1R5													
2	020													
3	030													
4	040	C												
5	050		P											
6	060													
7	070													
8	080													
9	090													
10	100		P											
12	120													
15	150													
18	180													
22	220													
27	270													
33	330													
39	390													
47	470													
56	560													
68	680													
82	820													
100	101													
120	121													
150	151													
180	181													
220	221													
270	271													
330	331													
390	391													
470	471													
560	561													
680	681													
820	821													
1000	102													

注：图表中的字母标记为产品厚度代码。
Note: Letters in the table indicate thickness.

温度特性 Temperature Characteristics

温度特性 Temperature char. (EIA)	温度系数范围 [ppm/°C] ※1 Temperature coefficient range	使用温度范围 Operating Temp. range
C K (C0K)	0±250	-55~+125°C
C J (C0J)	0±120	
C H (C0H)	0±60	
C G (C0G)	0±30	
R H (R2H)	-220±60	
S K (S2K)	-330±250	
S J (S2J)	-330±120	
S H (S2H)	-330±60	
T K (T2K)	-470±250	
T J (T2J)	-470±120	
U K (U2K)	-750±250	
U J (U2J)	-750±120	
S L	-1000~+350	

※1：以20°C的电容量为基准。
Based on the capacitance at 20°C

电容量公差 Capacitance Tolerance Symbol

记号 Symbol	公差 Tolerance	分类 Item
C	±0.25pF	~5pF
D	±0.5 pF	~10pF
F	±1pF	6~10 pF
J	±5 %	11pF~
K	±10 %	11pF~

Q

记号Q※2 Symbol	分类 Item
≥400+20·C※1	~27pF
≥1000	30pF~

※1：C=标称电容量 Nominal capacitance[pF]

※2：测试频率 Measurement Frequency= 1±0.1MHz (C≤1000pF)
1±0.1kHz (C>1000pF)

测试电压 Measurement voltage = 0.5~5Vrms (C≤1000pF)
1±0.2Vrms (C>1000pF)

选件指南
Selection Guide



etc

型号一览
Part Numbers



特性图
Electrical Characteristics



包装
Packaging



可靠性
Reliability Data



使用注意事项
Precautions



042型 042TYPE

1类 Class1

额定电压 Rated Voltage (DC)	型号 Ordering code	EHS (Environmental Hazardous Substances)	温度特性 Temperature characteristics (EIA)																	标称电 容 量 Capacitance [pF]	电容量 公差 Capacitance tolerance	厚度 Thicknees [mm] (inch)	
			CK (CK)	CJ (CJ)	CH (CH)	CG (CG)	PK (PK)	PJ (PJ)	PH (PH)	RK (RK)	RJ (RJ)	RH (RH)	SK (SK)	SJ (SJ)	SH (SH)	TK (TK)	TJ (TJ)	TH (TH)	UK (UK)				UJ (UJ)
16V	EMK042 CK0R5□C	RoHS	●																		0.5	±0.25pF ±0.5pF	0.2±0.02 (0.008±0.001)
	EMK042 CK010□C	RoHS	●																		1		
	EMK042 CK1R5□C	RoHS	●																		1.5		
	EMK042 CK020□C	RoHS	●																		2		
	EMK042 CJ030□C	RoHS		●																	3		
	EMK042 CH040□C	RoHS			●																4		
	EMK042 CH050□C	RoHS			●																5		
	EMK042 CH060□C	RoHS			●																6		
	EMK042 CH070□C	RoHS			●																7		
	EMK042 CH080□C	RoHS			●																8		
	EMK042 CH090□C	RoHS			●																9		
	EMK042 CH100□C	RoHS			●																10		
	EMK042 CH120□C	RoHS			●																12		
	EMK042 CH150□C	RoHS			●																15		
	EMK042 CH180□C	RoHS			●																18		
	EMK042 CH220□C	RoHS			●																22		
	EMK042 CH270□C	RoHS			●																27		
	EMK042 CH330□C	RoHS			●																33		
	EMK042 CH390□C	RoHS			●																39		
	EMK042 CH470□C	RoHS			●																47		
EMK042 CH560□C	RoHS			●																56			
EMK042 CH680□C	RoHS			●																68			
EMK042 CH820□C	RoHS			●																82			
EMK042 CH101□C	RoHS			●																100			

注：请在型号的□中指定电容量公差代码。
□ Please specify the capacitance tolerance code.

063型 063TYPE

1类 Class1

额定电压 Rated Voltage (DC)	型号 Ordering code	EHS (Environmental Hazardous Substances)	温度特性 Temperature characteristics (EIA)																	标称电 容 量 Capacitance [pF]	电容量 公差 Capacitance tolerance	厚度 Thicknees [mm] (inch)	
			CK (CK)	CJ (CJ)	CH (CH)	CG (CG)	PK (PK)	PJ (PJ)	PH (PH)	RK (RK)	RJ (RJ)	RH (RH)	SK (SK)	SJ (SJ)	SH (SH)	TK (TK)	TJ (TJ)	TH (TH)	UK (UK)				UJ (UJ)
25V	TMK063 △0R5□P	RoHS	●																		0.5	±0.25pF ±0.5pF	0.3±0.03 (0.012±0.001)
	TMK063 △010□P	RoHS	●																		1		
	TMK063 △1R5□P	RoHS	●																		1.5		
	TMK063 △020□P	RoHS	●																		2		
	TMK063 △030□P	RoHS		●																	3		
	TMK063 △040□P	RoHS			●																4		
	TMK063 △050□P	RoHS			●																5		
	TMK063 △060□P	RoHS			●																6		
	TMK063 △070□P	RoHS			●																7		
	TMK063 △080□P	RoHS			●																8		
	TMK063 △090□P	RoHS			●																9		
	TMK063 △100□P	RoHS			●																10		
	TMK063 △120□P	RoHS			●																12		
	TMK063 △150□P	RoHS			●																15		
	TMK063 CH180□P	RoHS			●																18		
	TMK063 CH220□P	RoHS			●																22		
	TMK063 CH270□P	RoHS			●																27		
	TMK063 CH330□P	RoHS			●																33		
	TMK063 CH390□P	RoHS			●																39		
	TMK063 CH470□P	RoHS			●																47		
TMK063 CH560□P	RoHS			●																56			
TMK063 CH680□P	RoHS			●																68			
TMK063 CH820□P	RoHS			●																82			
TMK063 CH101□P	RoHS			●																100			

注：请在型号的△中指定温度特性，在□中指定电容量公差代码。
△ Please specify the temperature characteristics code and □ the capacitance tolerance code.

105型 105TYPE

1类 Class1

额定电压 Rated Voltage (DC)	型号 Ordering code	EHS (Environmental Hazardous Substances)	温度特性 Temperature characteristics (EIA)																	标称电 容量 Capacitance [pF]	电容量 公差 Capacitance tolerance	厚度 Thicknees [mm] (inch)		
			CK	CJ	CH	CG	PK	PJ	PH	RK	RJ	RH	SK	SJ	SH	TK	TJ	TH	UK				UJ	SL
			(C0X)	(C0J)	(C0H)	(C0G)	(P2X)	(P2J)	(P2H)	(R2K)	(R2J)	(R2H)	(S2K)	(S2J)	(S2H)	(T2K)	(T2J)	(T2H)	(U2K)				(U2J)	
50V	UMK105 △ 0R5□W	RoHS	●															●			0.5	± 0.25pF ± 0.5pF	0.5±0.05 (0.020±0.002)	
	UMK105 △ 010□W	RoHS	●															●			1			
	UMK105 △ 1R5□W	RoHS	●															●			1.5			
	UMK105 △ 020□W	RoHS	●															●			2			
	UMK105 △ 030□W	RoHS		●														●			3			
	UMK105 △ 040□W	RoHS			●														●		4			
	UMK105 △ 050□W	RoHS				●													●		5			
	UMK105 △ 060□W	RoHS					●												●		6			
	UMK105 △ 070□W	RoHS						●											●		7			
	UMK105 △ 080□○	RoHS							●										●		8			
	UMK105 △ 090□○	RoHS								●									●		9			
	UMK105 △ 100□○	RoHS									●								●		10			
	UMK105 △ 120□○	RoHS										●							●		12			
	UMK105 △ 150□○	RoHS											●						●		15			
	UMK105 △ 180□○	RoHS												●					●		18			
	UMK105 △ 220□V	RoHS													●				●		22			
	UMK105 △ 270□V	RoHS														●			●		27			
	UMK105 △ 330□V	RoHS															●		●		33			
	UMK105 △ 390□V	RoHS																●	●		39			
	UMK105 △ 470□V	RoHS																	●	●	47			
	UMK105 △ 560□V	RoHS																		●	56			
	UMK105 △ 680□V	RoHS																		●	68			
	UMK105 △ 820□V	RoHS																		●	82			
	UMK105 △ 101□V	RoHS																		●	100			
	UMK105 △ 121□V	RoHS																		●	120			
	UMK105 △ 151□V	RoHS																		●	150			
	UMK105 △ 181□V	RoHS																		●	180			
	UMK105 △ 221□V	RoHS																		●	220			
	UMK105 △ 271□V	RoHS																		●	270			
	UMK105 △ 331□V	RoHS																		●	330			
	UMK105 SL121□V	RoHS																		●	120			
	UMK105 SL151□V	RoHS																		●	150			
	UMK105 SL181□V	RoHS																		●	180			
UMK105 SL221□V	RoHS																		●	220				
UMK105 SL271□V	RoHS																		●	270				
UMK105 SL331□V	RoHS																		●	330				

注:请在型号的△中指定温度特性,在□中指定电容量公差代码,CK、CJ、CH时在○内记入「V」,UK、UJ时在○内记入「W」。
△ Please specify the temperature characteristics code and □ the capacitance tolerance code. ○:CK,CJ,CH「V」, UK,UJ「W」.

105型 105TYPE

1类 Class1

额定电压 Rated Voltage (DC)	型号 Ordering code	EHS (Environmental Hazardous Substances)	温度特性 Temperature characteristics (EIA)																	标称电 容量 Capacitance [pF]	电容量 公差 Capacitance tolerance	厚度 Thicknees [mm] (inch)		
			CK	CJ	CH	CG	PK	PJ	PH	RK	RJ	RH	SK	SJ	SH	TK	TJ	TH	UK				UJ	SL
			(C0X)	(C0J)	(C0H)	(C0G)	(P2X)	(P2J)	(P2H)	(R2K)	(R2J)	(R2H)	(S2K)	(S2J)	(S2H)	(T2K)	(T2J)	(T2H)	(U2K)				(U2J)	
16V	EMK105 △ 0R5BW	RoHS										●									0.5	± 0.1pF	0.5±0.05 (0.020±0.002)	
	EMK105 △ 010BW	RoHS										●									1			
	EMK105 △ 1R2BW	RoHS										●									1.2			
	EMK105 △ 1R5BW	RoHS										●									1.5			
	EMK105 △ 1R8BW	RoHS										●									1.8			
	EMK105 △ 2R2JW	RoHS										●									2.2			
	EMK105 △ 2R7JW	RoHS										●									2.7			
	EMK105 △ 3R3JW	RoHS											●								3.3			
	EMK105 △ 3R9JW	RoHS												●							3.9			
	EMK105 △ 4R7JW	RoHS													●						4.7			
	EMK105 △ 5R6JW	RoHS														●					5.6			
	EMK105 △ 6R8JW	RoHS															●				6.8			
	EMK105 △ 8R2JW	RoHS																●			8.2			
	EMK105 △ 100JW	RoHS																	●		10			
	EMK105 △ 120JW	RoHS																		●	12			
	EMK105 △ 150JW	RoHS																			15			
	EMK105 △ 180JW	RoHS																			18			
	EMK105 △ 200JW	RoHS																			20			

注:请在型号的△中指定温度特性。
△ Please specify the temperature characteristics code.

107型 107TYPE

1类 Class1

额定电压 Rated Voltage (DC)	型号 Ordering code	EHS (Environmental Hazardous Substances)	温度特性 Temperature characteristics (EIA)																标称电 容 量 Capacitance [pF]	电容量 公差 Capacitance tolerance	厚度 Thicknees [mm] (inch)		
			CK (CK)	CJ (CJ)	CH (CH)	CG (CG)	PK (PK)	PJ (PJ)	PH (PH)	RK (RK)	RJ (RJ)	RH (RH)	SK (SK)	SJ (SJ)	SH (SH)	TK (TK)	TJ (TJ)	TH (TH)				UK (UK)	UJ (UJ)
50V	UMK107 △ 0R5 □ Z	RoHS	●																		0.5	± 0.25pF ± 0.5pF	0.8±0.10 (0.031±0.004)
	UMK107 △ 010 □ Z	RoHS	●																		1		
	UMK107 △ 1R5 □ Z	RoHS	●																		1.5		
	UMK107 △ 020 □ Z	RoHS	●																		2		
	UMK107 △ 030 □ Z	RoHS		●																	3		
	UMK107 △ 040 □ Z	RoHS			●																4		
	UMK107 △ 050 □ Z	RoHS			●																5		
	UMK107 △ 060 □ Z	RoHS			●																6		
	UMK107 △ 070 □ Z	RoHS			●																7		
	UMK107 △ 080 □ Z	RoHS			●																8		
	UMK107 △ 090 □ Z	RoHS			●																9		
	UMK107 △ 100 □ Z	RoHS			●	●															10		
	UMK107 △ 120 □ Z	RoHS			●	●															12		
	UMK107 △ 150 □ Z	RoHS			●	●															15		
	UMK107 △ 180 □ Z	RoHS			●	●															18		
	UMK107 △ 220 □ Z	RoHS			●	●															22		
	UMK107 △ 270 □ Z	RoHS			●	●															27		
	UMK107 △ 330 □ Z	RoHS			●	●															33		
	UMK107 △ 390 □ Z	RoHS			●	●															39		
	UMK107 △ 470 □ Z	RoHS			●	●															47		
	UMK107 △ 560 □ Z	RoHS			●	●															56		
	UMK107 △ 680 □ Z	RoHS			●	●															68		
	UMK107 △ 820 □ Z	RoHS			●	●															82		
	UMK107 △ 101 □ Z	RoHS			●	●															100		
	UMK107 △ 121 □ Z	RoHS			●	●															120		
	UMK107 △ 151 □ Z	RoHS			●	●															150		
	UMK107 △ 181 □ Z	RoHS			●	●															180		
	UMK107 △ 221 □ Z	RoHS			●	●															220		
	UMK107 △ 271 □ Z	RoHS			●	●															270		
	UMK107 △ 331 □ Z	RoHS			●	●															330		
UMK107 △ 391 □ Z	RoHS			●	●															390			
UMK107 △ 471 □ Z	RoHS			●	●															470			
UMK107 △ 561 □ Z	RoHS			●	●															560			
UMK107 △ 681 □ Z	RoHS			●	●															680			
UMK107 △ 821 □ Z	RoHS			●	●															820			
UMK107 △ 102 □ Z	RoHS			●	●															1000			

注:请在型号的△中指定温度特性, 在□中指定电容量公差代码。

△ Please specify the temperature characteristics code and □ the capacitance tolerance code.

标准多层陶瓷电容器 (2类: 高介电常数)

STANDARD MULTILAYER CERAMIC CAPACITORS (CLASS2 :HIGH DIELECTRIC CONSTANT TYPE)

使用温度 OPERATING TEMP.	代码 code	温度特性 Temp.characteristics	使用温度范围 operating Temp.range
	B/BJ	B	B
X5R		X5R	-55~+85°C
X7R		X7R	-55~+125°C
F		F	-25~+85°C
F	Y5V	Y5V	-30~+85°C

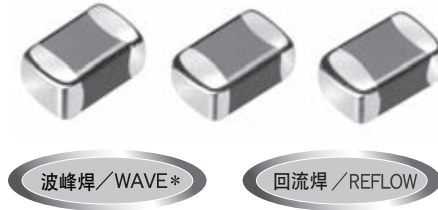

* 不包括042型, 063型, 105型
* Except for 042TYPE, 063TYPE, 105TYPE

特点 FEATURES

- 提高安装密度。
- 多层块状结构, 可靠性更高。
- 标准外型尺寸的电容器, 可提供更大的电容量范围。
- Improve Higher Mounting Densities.
- Multilayer block structure provides higher reliability
- A wide range of capacitance values available in standard case sizes.

用途 APPLICATIONS

- 一般电子设备
- 通讯设备 (手机、PHS、无绳电话等)
- General electronic equipment
- Communication equipment (cellular phone, PHS, other wireless applications, etc.)

型号标示法 ORDERING CODE

1 额定电压 (VDC)	4 外型尺寸 (EIA) 长×宽 (mm)	6 标称电容量 (pF)	7 电容量公差 (%)	9 个别规格
A 4 J 6.3 L 10 E 16 T 25 G 35 U 50	042(01005) 0.4×0.2 063(0201) 0.6×0.3 105(0402) 1.0×0.5 107(0603) 1.6×0.8	例 102 1000 223 22000	K ±10 M ±20 Z $\pm\frac{+80}{-20}$	- 标准
2 系列名称	5 温度特性代码	8 产品厚度 (mm)	10 包装	11 本公司管理记号
M 多层电容器	△B, BJ ±10% △F $\pm\frac{+30}{-80}$ % △=空格	C 0.2 P 0.3 V 0.5 Z 0.8	F 带装 (2mm间距·178φ) T 带装 (4mm间距·178φ)	△ 标准 △=空格
3 端接类型	L M K 1 0 5 B J 1 0 4 K V - F ○			
K 电镀	1 2 3 4 5 6 7 8 9 10 11			

1 Rated voltage (VDC)	4 Dimensions (case size) (L×W) (mm)	6 Nominal Capacitance (pF)	7 Capacitance Tolerance (%)	9 Special code
A 4 J 6.3 L 10 E 16 T 25 G 35 U 50	042(01005) 0.4×0.2 063(0201) 0.6×0.3 105(0402) 1.0×0.5 107(0603) 1.6×0.8	example 102 1000 223 22000	K ±10 M ±20 Z $\pm\frac{+80}{-20}$	- Standard products
2 Series name	5 Temperature characteristics code	8 Thickness (mm)	10 Packaging	11 Internal code
M Multilayer ceramic capacitors	B7 X7R -55~+125°C ±15% BJ X5R -55~+85°C ±15% △F Y5V -30~+85°C $\pm\frac{+30}{-80}$ % △=Blank space	C 0.2 P 0.3 V 0.5 Z 0.8	F Tape&Reel (2mm pitch·178φ) T Tape&Reel (4mm pitch·178φ)	△ Standard Products △=Blank space
3 End termination	K 电镀			

外型尺寸 EXTERNAL DIMENSIONS

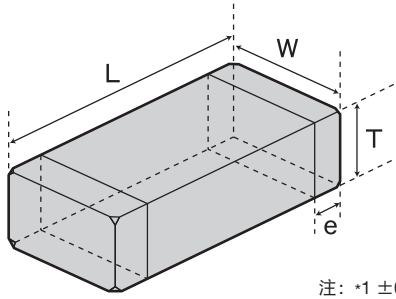

型号 Type (EIA)	长 L	宽 W	厚 T		端 e
□MK042 (01005)	0.4±0.02 (0.016±0.001)	0.2±0.02 (0.008±0.001)	0.2±0.02 (0.008±0.001)	C	0.1±0.03 (0.004±0.001)
□MK063 (0201)	0.6±0.03 (0.024±0.001)	0.3±0.03 (0.012±0.001)	0.3±0.03 (0.012±0.001)	P	0.15±0.05 (0.006±0.002)
□MK105 (0402)	1.0±0.05*1 (0.039±0.002)	0.5±0.05*1 (0.020±0.002)	0.5±0.05*1 (0.020±0.002)	V	0.25±0.10 (0.010±0.004)
□MK107 (0603)	1.6±0.10 (0.063±0.004)	0.8±0.10 (0.031±0.004)	0.8±0.10 (0.031±0.004)	Z	0.35±0.25 (0.014±0.010)

Unit : mm (inch)

注: *1 ±0.1mm公差
Not: *1 There is a tolerance of ±0.1mm.

电容量取值范围 AVAILABLE CAPACITANCE RANGE

■通用多层陶瓷电容器 (General Multilayer Ceramic capacitors)

型号 Type	042	063						105								107													
		B/X5R		B/X5R		X5R		B/X7R		B/X5R				X5R		F/Y5V		B/X7R		F/Y5V									
温度特性 Temp.char.	WV																												
电容量 Cap [pF]	10V	6.3V	25V	16V	10V	6.3V	10V	6.3V	4V	50V	25V	16V	35V	25V	16V	10V	6.3V	6.3V	4V	50V	25V	16V	10V	6.3V	50V	25V	50V	25V	
100																													
150																													
220																													
330																													
470																													
680																													
1000																													
1500																													
2200																													
3300																													
4700																													
6800																													
10000																													
15000																													
22000																													
33000																													
47000																													
68000																													
100000																													
220000																													
330000																													
470000																													

注: 图表中的字母标记为产品厚度代码。 Note: Letters in the table indicate thickness.

温度特性代码 Temp.char.Code	温度特性 Temperature characteristics					电容量公差 [%] Capacitance tolerance	损耗角正切 tan δ [%] Dissipation factor
	适用标准 Applicable standard	温度范围 [°C] Temperature range	基准温度 [°C] Ref. Temp.	电容量变化率 [%] Capacitance change			
B/BJ	JIS	B	-25~+85	20	±10	±10(K) ±20(M)	2.5 max.*
	EIA	X5R	-55~+85	25	±15		
B7	EIA	X7R	-55~+125	25	±15	+80(Z) -20	7.0 max.*
	JIS	F	-25~+85	20	+30/-80		
F	EIA	Y5V	-30~+85	25	+22/-82		

*: 此处数据为代表值。详情请参见型号一览表。
*: The figure indicates typical value. Please refer to PART NUMBERS table.

选件指南
Selection Guide



etc

型号一览
Part Numbers



特性图
Electrical Characteristics



包装
Packaging



可靠性
Reliability Data



使用注意事项
Precautions



型号一览 PART NUMBERS

■ 042 型 (01005 规格) 042TYPE (01005 case size)

【温度特性 Temp.char. BJ:B/X5R】

额定电压 Rated Voltage	型号 Ordering code	EHS (Environmental Hazardous Substances)	标称 电容量 Capacitance [pF]	温度特性 Temperature characteristics	tan δ 损耗角正切 Dissipation factor [%] Max.	焊接方式 Soldering method R:回流焊 Reflow soldering W:波峰焊 Wave soldering	电容量 公差 Capacitance tolerance	厚度 Thickness [mm] (inch)				
10V	LMK042 BJ101 □ C	RoHS	100	B/X5R	5	R	± 10% ± 20%	0.2 ± 0.02 (0.008 ± 0.001)				
	LMK042 BJ151 □ C	RoHS	150									
	LMK042 BJ221 □ C	RoHS	220									
	LMK042 BJ331 □ C	RoHS	330									
	LMK042 BJ471 □ C	RoHS	470									
	LMK042 BJ681 □ C	RoHS	680									
LMK042 BJ102 □ C	RoHS	1000										
6.3V	JMK042 BJ152 □ C*	RoHS	1500		10				10	R	± 10% ± 20%	0.2 ± 0.02 (0.008 ± 0.001)
	JMK042 BJ222 □ C*	RoHS	2200									
	JMK042 BJ332 □ C*	RoHS	3300									
	JMK042 BJ472 □ C*	RoHS	4700									
	JMK042 BJ682 □ C*	RoHS	6800									
	JMK042 BJ103 □ C*	RoHS	10000									

请在型号的□中指定电容量公差代码。

Please specify the capacitance tolerance code.

* 高温负载试验电压为额定电压的 1.5 倍。

* Test Voltage of Loading at high temperature test is 1.5 time of the rated voltage.

■ 063 型 (0201 规格) 063TYPE (0201 case size)

【温度特性 Temp.char. BJ:B/X5R】

额定电压 Rated Voltage	型号 Ordering code	EHS (Environmental Hazardous Substances)	标称 电容量 Capacitance [pF]	温度特性 Temperature characteristics	tan δ 损耗角正切 Dissipation factor [%] Max.	焊接方式 Soldering method R:回流焊 Reflow soldering W:波峰焊 Wave soldering	电容量 公差 Capacitance tolerance	厚度 Thickness [mm] (inch)				
25V	TMK063 BJ101 □ P	RoHS	100	B/X5R	3.5	R	±10% ±20%	0.3 ± 0.03 (0.012 ± 0.001)				
	TMK063 BJ151 □ P	RoHS	150									
	TMK063 BJ221 □ P	RoHS	220									
	TMK063 BJ331 □ P	RoHS	330									
	TMK063 BJ471 □ P	RoHS	470									
	TMK063 BJ681 □ P	RoHS	680									
TMK063 BJ102 □ P	RoHS	1000										
16V	EMK063 BJ152 □ P	RoHS	1500		5				5	R	±10% ±20%	0.3 ± 0.03 (0.012 ± 0.001)
	EMK063 BJ222 □ P	RoHS	2200									
	EMK063 BJ332 □ P	RoHS	3300									
10V	LMK063 BJ472 □ P	RoHS	4700		7.5				7.5	R	±10% ±20%	0.3 ± 0.03 (0.012 ± 0.001)
	LMK063 BJ682 □ P	RoHS	6800									
	LMK063 BJ103 □ P	RoHS	10000									
	LMK063 BJ223 □ P*	RoHS	22000									
6.3V	LMK063 BJ104 □ P*	RoHS	100000	10	10	R	±10% ±20%	0.3 ± 0.03 (0.012 ± 0.001)				
	JMK063 BJ473 □ P*	RoHS	47000									
	JMK063 BJ104 □ P*	RoHS	100000									
4V	JMK063 BJ224MP*	RoHS	220000	X5R	10	R	±20%	0.3 ± 0.03 (0.012 ± 0.001)				
	AMK063 BJ224MP*	RoHS	220000									
	AMK063 BJ334MP*	RoHS	330000									
	AMK063 BJ474MP*	RoHS	470000									

请在型号的□中指定电容量公差代码。

Please specify the capacitance tolerance code.

* 高温负载试验电压为额定电压的 1.5 倍。

* Test Voltage of Loading at high temperature test is 1.5 time of the rated voltage.

■ 105型 (0402规格) 105TYPE(0402 case size)

【温度特性 Temp.char. BJ:B/X5R】

额定电压 Rated Voltage	型号 Ordering code	EHS (Environmental Hazardous Substances)	标称 电容量 Capacitance [pF]	温度特性 Temperature characteristics	tan δ 损耗角正切 Dissipation factor [%]Max.	焊接方式 Soldering method R:回流焊 Reflow soldering W:波峰焊 Wave soldering	电容量 公差 Capacitance tolerance	厚度 Thickness [mm] (inch)
50V	UMK105 BJ221□V	RoHS	220	B/X5R**	2.5	R	±10% ±20%	0.5±0.05 (0.02 ± 0.002)
	UMK105 BJ331□V	RoHS	330					
	UMK105 BJ471□V	RoHS	470					
	UMK105 BJ681□V	RoHS	680					
	UMK105 BJ102□V	RoHS	1000					
	UMK105 BJ152□V	RoHS	1500					
	UMK105 BJ222□V	RoHS	2200					
35V	UMK105 BJ332□V	RoHS	3300	B/X5R	5	R	±10% ±20%	0.5±0.05 (0.02 ± 0.002)
	GMK105 BJ104□V*	RoHS	100000					
25V	TMK105 BJ472□V	RoHS	4700	B/X5R**	2.5	R	±10% ±20%	0.5±0.05 (0.02 ± 0.002)
	TMK105 BJ682□V	RoHS	6800					
	TMK105 BJ103□V	RoHS	10000	3.5				
	TMK105 BJ104□V*	RoHS	100000	B/X5R	5			
16V	EMK105 BJ153□V	RoHS	15000	B/X5R**	3.5	R	±10% ±20%	0.5±0.05 (0.02 ± 0.002)
	EMK105 BJ223□V	RoHS	22000					
	EMK105 BJ333□V	RoHS	33000					
	EMK105 BJ473□V	RoHS	47000	B/X5R	5			
	EMK105 BJ104□V*	RoHS	100000					
	EMK105 BJ224□V*	RoHS	220000					
10V	LMK105 BJ104□V	RoHS	100000	B/X5R	10	R	±10% ±20%	0.5±0.05 (0.02 ± 0.002)
	LMK105 BJ224□V*	RoHS	220000					
	LMK105 BJ474□V*	RoHS	470000		5			
	LMK105 BJ105□V*	RoHS	1000000		10			
6.3V	JMK105 BJ224□V*	RoHS	220000	X5R	10	R	±20%	0.5±0.1 (0.02 ± 0.004)
	JMK105 BJ474□V*	RoHS	470000					
	JMK105 BJ105□V*	RoHS	1000000					
	JMK105 BJ225MV*	RoHS	2200000					
4V	AMK105 BJ335MV*	RoHS	3300000	X5R	10	R	±20%	0.5±0.1 (0.02 ± 0.004)
	AMK105 BJ475MV*	RoHS	4700000					

**因个别规格约定, 将提供X7R规格对应的说明书。

**We may provide X7R for some items according to the individual specification.

【温度特性 Temp.char. B7:X7R】

额定电压 Rated Voltage	型号 Ordering code	EHS (Environmental Hazardous Substances)	标称 电容量 Capacitance [pF]	温度特性 Temperature characteristics	tan δ 损耗角正切 Dissipation factor [%]Max.	焊接方式 Soldering method R:回流焊 Reflow soldering W:波峰焊 Wave soldering	电容量 公差 Capacitance tolerance	厚度 Thickness [mm] (inch)
50V	UMK105 B7221□V	RoHS	220	X7R	2.5	R	±10% ±20%	0.5±0.05 (0.02 ± 0.002)
	UMK105 B7331□V	RoHS	330					
	UMK105 B7471□V	RoHS	470					
	UMK105 B7681□V	RoHS	680					
	UMK105 B7102□V	RoHS	1000					
	UMK105 B7152□V	RoHS	1500					
	UMK105 B7222□V	RoHS	2200					
25V	UMK105 B7332□V	RoHS	3300	X7R	3.5	R	±10% ±20%	0.5±0.05 (0.02 ± 0.002)
	TMK105 B7472□V	RoHS	4700					
	TMK105 B7682□V	RoHS	6800					
16V	TMK105 B7103□V	RoHS	10000	X7R	5	R	±10% ±20%	0.5±0.05 (0.02 ± 0.002)
	EMK105 B7153□V	RoHS	15000					
	EMK105 B7223□V	RoHS	22000					
	EMK105 B7333□V	RoHS	33000					
	EMK105 B7473□V	RoHS	47000					
EMK105 B7104□V*	RoHS	100000						

请在型号的□中指定电容量公差代码。

□ Please specify the capacitance tolerance code.

* 高温负载试验电压为额定电压的 1.5 倍。

* Test Voltage of Loading at high temperature test is 1.5 time of the rated voltage.

【温度特性 Temp.char. F:Y5V】

额定电压 Rated Voltage	型号 Ordering code		EHS (Environmental Hazardous Substances)	标称 电容量 Capacitance [pF]	温度特性 Temperature characteristics	tanδ 损耗角正切 Dissipation factor [%] Max.	焊接方式 Soldering method R:回流焊 Reflow soldering W:波峰焊 Wave soldering	电容量 公差 Capacitance tolerance	厚度 Thickness [mm] (inch)
50V	UMK105 F103ZV		RoHS	10000	F/Y5V	5	R	+80% -20%	0.5±0.05 (0.02±0.002)
25V	TMK105 F223ZV		RoHS	22000		7			
16V	EMK105 F473ZV		RoHS	47000		9			
	EMK105 F104ZV		RoHS	100000		11			
10V	LMK105 F224ZV		RoHS	220000		16			
6.3V	JMK105 F474ZV		RoHS	470000		20			
	JMK105 F105ZV*		RoHS	1000000					

* 高温负载试验电压为额定电压的 1.5 倍。

* Test Voltage of Loading at high temperature test is 1.5 time of the rated voltage.

■ 107 型 (0603 规格) 107TYPE (0603 case size)

额定电压 Rated Voltage	型号 Ordering code		EHS (Environmental Hazardous Substances)	标称 电容量 Capacitance [pF]	温度特性 Temperature characteristics	tanδ 损耗角正切 Dissipation factor [%] Max.	焊接方式 Soldering method R:回流焊 Reflow soldering W:波峰焊 Wave soldering	电容量 公差 Capacitance tolerance	厚度 Thickness [mm] (inch)
50V	UMK107 B102□Z		RoHS	1000	B/X7R	2.5	R/W	±10% ±20%	0.8±0.1 (0.03±0.004)
	UMK107 B152□Z		RoHS	1500					
	UMK107 B222□Z		RoHS	2200					
	UMK107 B332□Z		RoHS	3300					
	UMK107 B472□Z		RoHS	4700					
	UMK107 B682□Z		RoHS	6800					
25V	UMK107 B103□Z		RoHS	10000	F/Y5V	5	R/W	+80% -20%	0.8±0.1 (0.03±0.004)
	TMK107 B153□Z		RoHS	15000					
TMK107 B223□Z		RoHS	22000						
50V	UMK107 F103ZZ		RoHS	10000					
	UMK107 F223ZZ		RoHS	22000					
25V	TMK107 F473ZZ		RoHS	47000					
	TMK107 F104ZZ		RoHS	100000					

请在型号的□中指定电容量公差代码。

Please specify the capacitance tolerance code.

高频多层陶瓷电容器 (1GHz+)

MULTILAYER CERAMIC CAPACITORS FOR HIGH FREQUENCY APPLICATIONS(1GHz+)

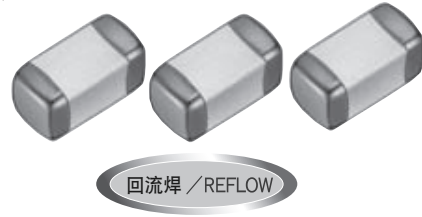

使用温度 OPERATING TEMP. -55~+125°C

特点 FEATURES

- 与其他多层电容器相比，其高频段 (1GHz+) 的Q值较高。
- 1005 (0402) 规格设计可实现高密度，轻量化安装。
- Q values in the high frequency range (1 GHz+) are excellent compared to other types of multilayer capacitors.
- The 1005(0402) case size is designed for high density mounting and weight reduction in various applications.

用途 APPLICATIONS

- 适用于要求高Q值和小型化的高频应用，如便携式通讯产品和其他无线设备。VCO、TCXO等。
- 可调整高频电路特性。
- Suitable for those high frequency applications in which a capacitor with both a high Q-value and small size is required such as portable communications and other wireless applications. VCO, TCXO. etc.
- Adjustment of characteristics in high frequency circuit

型号标示法 ORDERING CODE

1 额定电压 (VDC) E 16 U 50	4 外形尺寸 (EIA) 长×宽 (mm) 105(0402) 1.0×0.5	6 标称电容量 (pF) 例 020 2 4R3 4.3 ※R=小数点	8 产品厚度 (mm) W 0.5	10 包装 F 卷盘带装 (178φ2mm间距)
2 系列名称 V 高频多层陶瓷电容器	5 温度特性 (ppm/°C) CH 0±60 RH -220±60	7 电容量公差 B ±0.1pF J ±5%	9 产品厚度 — 标准	
3 端接类型 K 电镀				

U V K 1 0 5 R H 4 R 3 J W - F

1 2 3 4 5 6 7 8 9 10

1 Rated voltage (VDC) E 16 U 50	4 Dimensions (case size) (L×W) (mm) 105(0402) 1.0×0.5	6 Nominal Capacitance (pF) example 020 2 4R3 4.3 ※R=Decimal point	8 Thickness (mm) W 0.5	10 Packaging F Tape&Reel(2mm pitch·178φ)
2 Series name V MULTILAYER CERAMIC CAPACITORS FOR HIGH FREQUENCY	5 Temperature characteristics (ppm/°C) CH 0±60 RH -220±60	7 Capacitance Tolerances B ±0.1pF J ±5%	9 Special code — Standard Products	
3 End termination K Plated				

外型尺寸 EXTERNAL DIMENSIONS

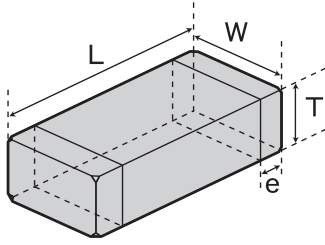

类型Type(EIA)	长 L	宽 W	厚 T	端 e
<input type="checkbox"/> VK105 (0402)	1.0±0.05 (0.039±0.002)	0.5±0.05 (0.020±0.002)	0.5±0.05 (0.020±0.002)	0.25±0.1 (0.010±0.004)

Unit : mm (inch)

型号一览 PART NUMBERS

额定电压 Rated Voltage (DC)	型号 Ordering code	EHS (Environmental Hazardous Substances)	温度特性 Temperature characteristics		标称电容量 Capacitance [pF]	电容量公差 Capacitance tolerance	Q额定值 (at 1GHz) Q (min)	厚度 Thickness [mm]	Q标准值 (典型值) Typical Q
			CH	RH					
E: 16V U: 50V	<input type="checkbox"/> VK105 CH0R3BW	RoHS	●		0.3	±0.1pF	300	0.5±0.05	1200
	<input type="checkbox"/> VK105 CH0R4BW	RoHS	●		0.4		300		1200
	<input type="checkbox"/> VK105 CH0R5BW	RoHS	●		0.5		300		1200
	<input type="checkbox"/> VK105 CH0R6BW	RoHS	●		0.6		300		1100
	<input type="checkbox"/> VK105 CH0R7BW	RoHS	●		0.7		300		1100
	<input type="checkbox"/> VK105 CH0R8BW	RoHS	●		0.8		300		1000
	<input type="checkbox"/> VK105 CH0R9BW	RoHS	●		0.9		300		950
	<input type="checkbox"/> VK105 CH010BW	RoHS	●		1.0		300		950
	<input type="checkbox"/> VK105 CH1R1BW	RoHS	●		1.1		280		930
	<input type="checkbox"/> VK105 CH1R2BW	RoHS	●		1.2		270		850
	<input type="checkbox"/> VK105 CH1R3BW	RoHS	●		1.3		260		740
	<input type="checkbox"/> VK105 CH1R5BW	RoHS	●		1.5		240		710
	<input type="checkbox"/> VK105 CH1R6BW	RoHS	●		1.6		230		670
	<input type="checkbox"/> VK105 CH1R8BW	RoHS	●		1.8		210		650
	<input type="checkbox"/> VK105 CH020BW	RoHS	●		2.0		190		610
	<input type="checkbox"/> VK105 CH2R2JW	RoHS	●		2.2		180		530
	<input type="checkbox"/> VK105 CH2R4JW	RoHS	●		2.4		170		510
	<input type="checkbox"/> VK105 CH2R7JW	RoHS	●		2.7		150		460
	<input type="checkbox"/> VK105 CH030JW	RoHS	●		3.0		130		390
	<input type="checkbox"/> VK105 CH3R3JW	RoHS	●		3.3		120		370
	<input type="checkbox"/> VK105 CH3R6JW	RoHS	●		3.6	110	360		
	<input type="checkbox"/> VK105 CH3R9JW	RoHS	●		3.9	99	360		
	<input type="checkbox"/> VK105 CH4R3JW	RoHS	●		4.3	84	360		
	<input type="checkbox"/> VK105 CH4R7JW	RoHS	●		4.7	84	340		
	<input type="checkbox"/> VK105 CH5R1JW	RoHS	●		5.1	84	320		
	<input type="checkbox"/> VK105 RH0R5BW	RoHS		●	0.5	±0.1pF	300		1100
	<input type="checkbox"/> VK105 RH0R6BW	RoHS		●	0.6		300		1000
	<input type="checkbox"/> VK105 RH0R7BW	RoHS		●	0.7		300		1000
	<input type="checkbox"/> VK105 RH0R8BW	RoHS		●	0.8		300		970
	<input type="checkbox"/> VK105 RH0R9BW	RoHS		●	0.9		300		950
	<input type="checkbox"/> VK105 RH010BW	RoHS		●	1.0		300		900
	<input type="checkbox"/> VK105 RH1R1BW	RoHS		●	1.1		280		900
	<input type="checkbox"/> VK105 RH1R2BW	RoHS		●	1.2		270		740
	<input type="checkbox"/> VK105 RH1R3BW	RoHS		●	1.3		260		700
	<input type="checkbox"/> VK105 RH1R5BW	RoHS		●	1.5		240		680
	<input type="checkbox"/> VK105 RH1R6BW	RoHS		●	1.6		230		640
	<input type="checkbox"/> VK105 RH1R8BW	RoHS		●	1.8		210		620
	<input type="checkbox"/> VK105 RH020BW	RoHS		●	2.0		190		570
	<input type="checkbox"/> VK105 RH2R2JW	RoHS		●	2.2		180		480
	<input type="checkbox"/> VK105 RH2R4JW	RoHS		●	2.4		170		470
	<input type="checkbox"/> VK105 RH2R7JW	RoHS		●	2.7		150		420
	<input type="checkbox"/> VK105 RH030JW	RoHS		●	3.0		130		360
	<input type="checkbox"/> VK105 RH3R3JW	RoHS		●	3.3		120		350
	<input type="checkbox"/> VK105 RH3R6JW	RoHS		●	3.6		110		340
	<input type="checkbox"/> VK105 RH3R9JW	RoHS		●	3.9		99		340
	<input type="checkbox"/> VK105 RH4R3JW	RoHS		●	4.3	84	340		
	<input type="checkbox"/> VK105 RH4R7JW	RoHS		●	4.7	84	320		
	<input type="checkbox"/> VK105 RH5R1JW	RoHS		●	5.1	84	310		

注：请在型号的中指定额定电压代码。 Please specify the Rated Voltage code.

规格 SPECIFICATIONS

温度特性 Temperature Characteristics	使用温度范围 Operating Temperature range	温度系数范围 Temperature Coefficient range [ppm/°C]	电容量公差 Capacitance Tolerance (分类)
CH	-55~+125°C	0±60	±0.1pF (~2.0pF)
RH		-220±60	±5% (2.2pF~)

■电容量与Q值关系 (CH特性例) Capacitance vs Q value (Typical for CH T.C.)

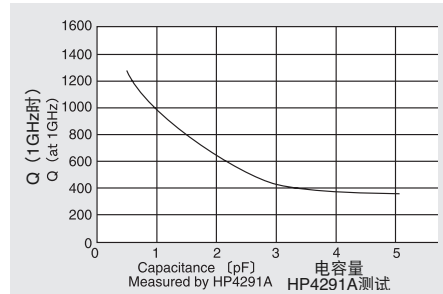

选件指南
Selection Guide



etc

型号一览
Part Numbers



特性图
Electrical Characteristics



包装
Packaging



可靠性
Reliability Data



使用注意事项
Precautions



超低失真多层陶瓷电容器 (CFCAP[®])

SUPER LOW DISTORTION MULTILAYER CERAMIC CAPACITORS (CFCAP[®])

使用温度 OPERATING TEMP. -55~+125°C



回流焊 / REFLOW

特点 FEATURES

- 采用新开发的介电材料，并采用金属镍作为内部电极，温度特性好、小型化、大容量、低成本。
- 失真小，冲击噪声低，适用于模拟或便携数字电路。
- 耐热性能优异、击穿电压高、机械强度高，适合替代薄膜电容器。

- Newly developed dielectric material and the use of nickel for internal electrodes provide excellent temperature characteristics with high capacitance, small case size and low cost.
- Low distortion and low shock noise make these capacitors well suited for use in analog or digital mobile devices.
- Excellent heat-resistance, high break down voltage, and mechanical strength make these capacitors well suited for replacing film capacitors.

用途 APPLICATIONS

- AV产品信号线路
- 模拟信号耦合
- 手机的PLL电路
- 良好的温度特性，可用于定时电路、振荡电路及滤波器等

- Signal line for AV products
- Analog signal coupling applications
- PLL circuit of mobile phones
- Good temperature characteristics for time constant circuits, oscillation circuits and filters

型号标示法 ORDERING CODE

1 额定电压 [VDC]	
U	50
G	35
T	25
E	16
L	10
2 系列名称	
M	多层电容器

3 端接类型	
K	电镀
4 外型尺寸 (EIA) 长×宽 (mm)	
105 (0402)	1.0×0.5
107 (0603)	1.6×0.8
212 (0805)	2.0×1.25
316 (1206)	3.2×1.6

5 系列码	
SD	标准品
6 标称电容量 (μF)	
例	
223	0.022
104	0.1

7 电容量公差	
K	±10 %
8 产品厚度 (mm)	
V	0.5
A	0.8
D	0.85
F	1.15
G	1.25
L	1.6

9 个别规格	
-	标准
10 包装	
T	卷盘带装 (4mm间距)
F	卷盘带装 (2mm间距)
11 本公司管理记号	
○	标准品
○	= 空格

T M K 3 1 6 S D 1 0 4 K L - T ○

1 2 3 4 5 6 7 8 9 10 11

1 Rated voltage [VDC]	
U	50
G	35
T	25
E	16
L	10
2 Series name	
M	Multilayer ceramic capacitors

3 End termination	
K	Plated
4 Dimensions(case size) (mm)	
105 (0402)	1.0×0.5
107 (0603)	1.6×0.8
212 (0805)	2.0×1.25
316 (1206)	3.2×1.6

5 Series Symbol	
SD	Standard
6 Nominal capacitance (μF)	
example	
223	0.022
104	0.1

7 Capacitance tolerances (%)	
K	±10
8 Thickness (mm)	
V	0.5
A	0.8
D	0.85
F	1.15
G	1.25
L	1.6

9 Special code	
-	Standard products
10 Packaging	
T	Tape & reel (4mm pitches)
F	Tape & reel (2mm pitches)
11 Internal code	
○	Standard products
○	= Blank space

外型尺寸 EXTERNAL DIMENSIONS

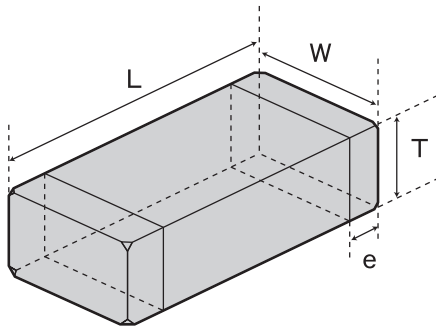

类型 Type (EIA)	长 L	宽 W	厚 T		端 e
□MK105 (0402)	1.0±0.05 (0.039±0.002)	0.5±0.05 (0.020±0.002)	0.5±0.05 (0.020±0.002)	V	0.25±0.10 (0.010±0.004)
□MK107 (0603)	1.6±0.10 (0.063±0.004)	0.8±0.10 (0.031±0.004)	0.8±0.10 (0.031±0.004)	A	0.35±0.25 (0.014±0.010)
□MK212 (0805)	2.0±0.10 (0.079±0.004)	1.25±0.10 (0.049±0.004)	0.85±0.10 (0.033±0.004)	D	0.5±0.25 (0.020±0.010)
			1.25±0.10 (0.049±0.004)	G	
□MK316 (1206)	3.2±0.15 (0.126±0.006)	1.6±0.15 (0.063±0.006)	1.15±0.10 (0.045±0.004)	F	0.5 ^{+0.35} _{-0.25} (0.020 ^{+0.014} _{-0.010})
			1.6±0.20 (0.063±0.008)	L	

Unit : mm (inch)

4

CAPACITORS

电容量取值范围 AVAILABLE CAPACITANCE RANGE

电容量 Cap [μF]	类型 Type 温度特性 Temp. Char. VDC [pF:3digits]	105				107				212				316	
		SD				SD				SD				SD	
		50V	25V	16V	10V	50V	25V	16V	10V	50V	35V	16V	10V	35V	25V
0.00039	391	V													
0.00047	471	V													
0.00056	561	V													
0.00068	681		V												
0.00082	821		V												
0.001	102		V			A									
0.0012	122		V			A									
0.0015	152			V		A									
0.0018	182			V		A									
0.0022	222			V		A									
0.0027	272			V		A									
0.0033	332				V	A									
0.0039	392				V		A			D					
0.0047	472				V		A			D					
0.0056	562						A			D					
0.0068	682						A			D					
0.0082	822						A			D					
0.01	103						A			D					
0.012	123							A			D				
0.015	153							A			D				
0.018	183							A			G				
0.022	223							A			G				
0.027	273										G				
0.033	333											D		F	
0.039	393													F	
0.047	473												D		F
0.056	563														F
0.068	683													G	F
0.082	823													G	L
0.1	104													G	L

※图表中的字母标记为产品厚度代码。 Letters in the table indicate thickness.

系列名称 Series Code	电容量公差 [%] Capacitance tolerance	损耗角正切 tan δ [%] Dissipation factor
SD	±10 (K)	0.1max.

选件指南
Selection Guide



型号一览
Part Numbers



特性图
Electrical Characteristics



包装
Packaging



可靠性
Reliability Data



使用注意事项
Precautions



型号一览 PART NUMBERS

■105型(0402规格) 105TYPE(0402 case size)

额定电压 Rated Voltage	型号 Ordering code	EHS (Environmental Hazardous Substances)	标称电容量 Capacitance [μ F]	温度特性 Temperature characteristics Standard type	$\tan \delta$ 损耗角正切 Dissipation factor [%]Max.	焊接方式 Soldering method R:回流焊 Reflow soldering W:波峰焊 Wave soldering	电容量公差 Capacitance tolerance	厚度 Thickness [mm] (inch)
50V	UMK105 SD391KV	RoHS	0.00039	Standard type	0.1	R	$\pm 10\%^*$	0.5 \pm 0.05 (0.020 \pm 0.002)
	UMK105 SD471KV	RoHS	0.00047					
UMK105 SD561KV	RoHS	0.00056						
25V	TMK105 SD681KV	RoHS	0.00068					
	TMK105 SD821KV	RoHS	0.00082					
	TMK105 SD102KV	RoHS	0.0010					
16V	TMK105 SD122KV	RoHS	0.0012					
	EMK105 SD152KV	RoHS	0.0015					
	EMK105 SD182KV	RoHS	0.0018					
	EMK105 SD222KV	RoHS	0.0022					
10V	EMK105 SD272KV	RoHS	0.0027					
	LMK105 SD332KV	RoHS	0.0033					
	LMK105 SD392KV	RoHS	0.0039					
	LMK105 SD472KV	RoHS	0.0047					

: 也对应“J”公差($\pm 5\%$)产品。详情请咨询当地销售部门。: The product with "J" tolerance of $\pm 5\%$ is also available. Please contact our local sales.

■107型(0603规格) 107TYPE(0603 case size)

额定电压 Rated Voltage	型号 Ordering code	EHS (Environmental Hazardous Substances)	标称电容量 Capacitance [μ F]	温度特性 Temperature characteristics Standard type	$\tan \delta$ 损耗角正切 Dissipation factor [%]Max.	焊接方式 Soldering method R:回流焊 Reflow soldering W:波峰焊 Wave soldering	电容量公差 Capacitance tolerance	厚度 Thickness [mm] (inch)
50V	UMK107 SD102KA	RoHS	0.0010	Standard type	0.1	R	$\pm 10\%^*$	0.8 \pm 0.1 (0.031 \pm 0.004)
	UMK107 SD122KA	RoHS	0.0012					
	UMK107 SD152KA	RoHS	0.0015					
	UMK107 SD182KA	RoHS	0.0018					
	UMK107 SD222KA	RoHS	0.0022					
	UMK107 SD272KA	RoHS	0.0027					
25V	UMK107 SD332KA	RoHS	0.0033					
	TMK107 SD392KA	RoHS	0.0039					
	TMK107 SD472KA	RoHS	0.0047					
16V	EMK107 SD562KA	RoHS	0.0056					
	EMK107 SD682KA	RoHS	0.0068					
	EMK107 SD822KA	RoHS	0.0082					
	EMK107 SD103KA	RoHS	0.010					
10V	LMK107 SD123KA	RoHS	0.012					
	LMK107 SD153KA	RoHS	0.015					
	LMK107 SD183KA	RoHS	0.018					
	LMK107 SD223KA	RoHS	0.022					

: 也对应“J”公差($\pm 5\%$)产品。详情请咨询当地销售部门。: The product with "J" tolerance of $\pm 5\%$ is also available. Please contact our local sales.

■212型(0805规格) 212TYPE(0805 case size)

额定电压 Rated Voltage	型号 Ordering code	EHS (Environmental Hazardous Substances)	标称电容量 Capacitance [μ F]	温度特性 Temperature characteristics Standard type	$\tan \delta$ 损耗角正切 Dissipation factor [%]Max.	焊接方式 Soldering method R:回流焊 Reflow soldering W:波峰焊 Wave soldering	电容量公差 Capacitance tolerance	厚度 Thickness [mm] (inch)
50V	UMK212 SD392KD	RoHS	0.0039	Standard type	0.1	R	$\pm 10\%^*$	0.85 \pm 0.1 (0.033 \pm 0.004)
	UMK212 SD472KD	RoHS	0.0047					
	UMK212 SD562KD	RoHS	0.0056					
	UMK212 SD682KD	RoHS	0.0068					
	UMK212 SD822KD	RoHS	0.0082					
35V	UMK212 SD103KD	RoHS	0.01					
	GMK212 SD123KD	RoHS	0.012					
	GMK212 SD153KD	RoHS	0.015					
	GMK212 SD183KG	RoHS	0.018					
	GMK212 SD223KG	RoHS	0.022					
	GMK212 SD273KG	RoHS	0.027					
16V	EMK212 SD333KD	RoHS	0.033					
	LMK212 SD473KD	RoHS	0.047					
10V	LMK212 SD683KG	RoHS	0.068					
	LMK212 SD823KG	RoHS	0.082					
	LMK212 SD104KG	RoHS	0.1					

: 也对应“J”公差($\pm 5\%$)产品。详情请咨询当地销售部门。: The product with "J" tolerance of $\pm 5\%$ is also available. Please contact our local sales.

■316型(1206规格) 316TYPE(1206 case size)

额定电压 Rated Voltage	型号 Ordering code	EHS (Environmental Hazardous Substances)	标称电容量 Capacitance [μ F]	温度特性 Temperature characteristics Standard type	$\tan \delta$ 损耗角正切 Dissipation factor [%]Max.	焊接方式 Soldering method R:回流焊 Reflow soldering W:波峰焊 Wave soldering	电容量公差 Capacitance tolerance	厚度 Thickness [mm] (inch)
35V	GMK316 SD333KF	RoHS	0.033	Standard type	0.1	R	$\pm 10\%^*$	1.15 \pm 0.1 (0.045 \pm 0.004)
	GMK316 SD393KF	RoHS	0.039					
	TMK316 SD473KF	RoHS	0.047					
25V	TMK316 SD563KF	RoHS	0.056					
	TMK316 SD683KF	RoHS	0.068					
	TMK316 SD823KL	RoHS	0.082					
	TMK316 SD104KL	RoHS	0.1					

: 也对应“J”公差($\pm 5\%$)产品。详情请咨询当地销售部门。: The product with "J" tolerance of $\pm 5\%$ is also available. Please contact our local sales.

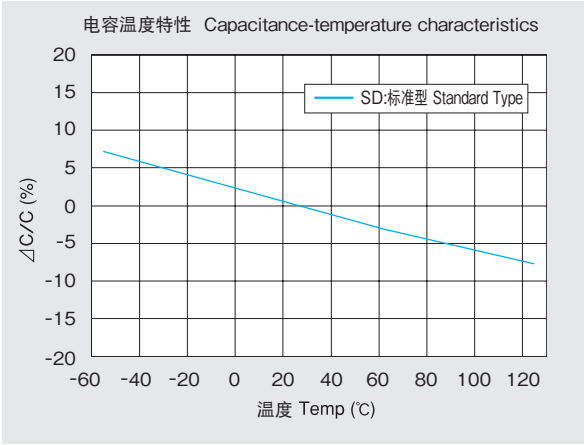

超低失真多层陶瓷电容器 (CFCAP)

项 目	规 格 值	试验方法·摘要
1.使用温度范围	-55~+125℃	
2.保存温度范围	-55~+125℃	
3.额定电压	10VDC, 16VDC, 25VDC, 35VDC, 50VDC,	
4.耐电压 (端子间)	无击穿或破损	外加电压: 额定电压×3 外加时间: 1~5秒 充放电电流: 50mA以下
5.绝缘阻抗	10000MΩ或500MΩ μF, 任一较小值以上	外加电压: 额定电压 外加时间: 60±5秒 充放电电流: 50mA以下
6.电容量 (公差)	±10%	测试频率: 1kHz±10% 测试电压: 1±0.2Vrms 外加偏压: 无
7.损耗角正切 (tan δ)	0.1%以下	测试频率: 1kHz±10% 测试电压: 1±0.2Vrms 外加偏压: 无
8.印刷线路板耐弯曲性	外观: 无异常 电容量变化: ±5%	弯曲量: 1mm 加压速度: 0.5mm/秒 外加时间: 10秒 应在印刷线路板弯曲状态下测试。 材料: 玻璃基材、环氧树脂线路板 镀铜 (厚度 0.035mm) 阻焊剂
9.抗折强度		
10.端子电极固着力	端子电极无松动及其他不良现象。	加压荷重: 5N 外加时间: 30±5秒
11.可焊性	端子电极不少于95%的面积覆盖新涂层。	焊锡温度: 230±5℃ 浸渍时间: 4±1秒
12.焊接耐热性	外观: 无异常 电容量变化: ±2.5%以内 tan δ: 初期规定值 绝缘阻抗: 初期规定值 耐电压 (端子间): 无异常	焊锡温度: 270±5℃ 浸渍时间: 3±0.5秒 预热条件: 80~100℃ 2~5分钟或5~10分钟 150~200℃ 2~5分钟或5~10分钟 后期处理: 测试后在标准状态下放置24±2小时
13.温度循环	外观: 无异常 电容量变化: ±2.5%以内 tan δ: 初期规定值 绝缘阻抗: 初期规定值 耐电压 (端子间): 无异常	1回循环条件/步骤1: 最低使用温度 -3℃ 30±3分钟 步骤2: 常温 2~3分钟 步骤3: 最高使用温度 -0℃ 30±3分钟 步骤4: 常温 2~3分钟 测试次数: 5回 试验后静放时间: 24±2小时
14.耐湿性 (稳态)	外观: 无异常 电容量变化: ±5%以内 tan δ: 0.5%以下 绝缘阻抗: 50MΩ μF或1000MΩ, 任一较小值以上	温度: 40±2℃ 湿度: 90~95%RH 试验时间: 500 ⁺²⁴ ₀ 小时 后期处理: 从试验容器中取出后, 在标准状态下放置24±2小时

超低失真多层陶瓷电容器 (CFCAP)

项 目	规 格 值	试验方法·摘要
15.耐湿负载	外观：无异常 电容量变化：±7.5%以内 tan δ：0.5%以下 绝缘阻抗：25MΩ μF或500MΩ，任一较小值以上	根据JIS C 5102规范9.9项。 温度：40±2℃ 湿度：90~95%RH 试验时间：500 ⁺²⁴ ₋₀ 时间 外加电压：额定电压 充放电电流：小于50mA 后期处理：从试验容器中取出后，在标准状态下放置 24±2小时
16.高温负载	外观：无异常 电容量变化：±3%以内 tan δ：0.35%以下 绝缘阻抗：50MΩ μF或1000MΩ，任一较小值以上	根据JIS C 5102规范9.10项。 温度：125±3℃ 试验时间：1000 ⁺⁴⁸ ₋₀ 时间 外加电压：额定电压×2 后期处理：从试验容器中取出后，在标准状态下放置 24±2小时

"标准状态"为：温度5~35℃、相对湿度45~85%、气压86~106kPa

对测试结果存有疑义时，则在以下条件下进行测试：

温度20±2℃、相对湿度60~70%、气压86~106kPa

如无特别指定，所有测试全部在"标准状态"下进行。

中高耐压多层陶瓷电容器

MEDIUM-HIGH VOLTAGE MULTILAYER CERAMIC CAPACITOR

	代码 code	温度特性 Temp.characteristics	使用温度范围 operating Temp. range
使用温度	BJ	B	-25~+85°C
		X5R	-55~+85°C
OPERATING TEMP.	B7	X7R	-55~+125°C
	C7	X7S	-55~+125°C

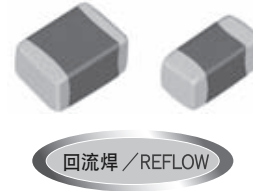

特点 FEATURES

- 内部电极采用金属镍，避免迁移，可靠性高
- 尺寸小，额定电压高

- The use of Nickel(Ni) as material for internal electrodes almost completely eliminates migration and high reliability
- Small case sizes with high rated voltage

用途 APPLICATIONS

- 一般电话交换机
- 逆变器
- 无线通讯基地
- DC/DC变换器用

- General telephone exchange
- Inverter.
- Wireless and Telecommunication base.
- For DC/DC Converter

型号标示法 ORDERING CODE

1 额定电压 (VDC)	3 端接类型	5 温度特性 (%)	7 电容量公差	9 个别规格
H 100 Q 250 S 630	K 电镀	B J B ±10	K ±10% M ±20%	- 标准品
2 系列名称	4 外型尺寸 (EIA)长×宽 (mm)	6 标称电容量 (pF)	8 产品厚度 (mm)	10 包装
M 多层电容器	107 (0603) 1.6×0.8 212 (0805) 2.0×1.25 316 (1206) 3.2×1.6 325 (1210) 3.2×2.5 432 (1812) 4.5×3.2	例 104 100,000 105 1,000,000	A 0.8 D 0.85 G 1.25 F 1.15 L 1.6 N 1.9 M 2.5	T 卷盘带装
				11 本公司管理记号
				△ 标准品 △=空格

H M K 3 1 6 B J 1 0 4 K L - T ○

1 2 3 4 5 6 7 8 9 10 11

1 Rated voltage (VDC)	3 End termination	5 Temperature characteristics code	7 Capacitance tolerances (%)	9 Special code
H 100 Q 250 S 630	K Plated	B 7 X7R -55~+125°C±15% C 7 X7S -55~+125°C±22%	K ±10 M ±20	- Standard products
2 Series name	4 Dimensions(case size) (mm)	6 Nominal capacitance (pF)	8 Thickness (mm)	10 Packaging
M Multilayer ceramic capacitors	107 (0603) 1.6×0.8 212 (0805) 2.0×1.25 316 (1206) 3.2×1.6 325 (1210) 3.2×2.5 432 (1812) 4.5×3.2	example 104 100,000 105 1,000,000	A 0.8 D 0.85 G 1.25 F 1.15 L 1.6 N 1.9 M 2.5	T Tape & reel
				11 Internal code
				△ Standard products △=Blank space

外型尺寸 EXTERNAL DIMENSIONS

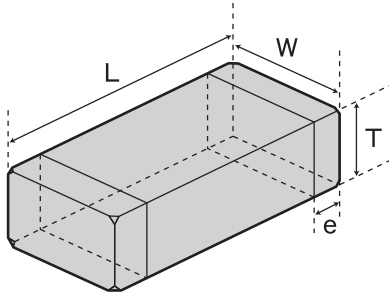

型号 Type (EIA)	长 L	宽 W	厚 T		端 e
□MK107 (0603)	1.6±0.10 (0.063±0.004)	0.8±0.10 (0.031±0.004)	0.8±0.10 (0.031±0.004)	A	0.35±0.25 (0.014±0.010)
□MK212 (0805)	2.0±0.10 (0.079±0.004)	1.25±0.10 (0.049±0.004)	0.85±0.10 (0.033±0.004)	D	0.5±0.25 (0.020±0.010)
			1.25±0.10 (0.049±0.004)	G	
□MK316 (1206)	3.2±0.15 (0.126±0.006)	1.6±0.15 (0.063±0.006)	1.15±0.10 (0.045±0.004)	F	0.5 ^{+0.35} _{-0.25} (0.020 ^{+0.014} _{-0.010})
			1.6±0.20 (0.063±0.008)	L	
□MK325 (1210)	3.2±0.3 (0.126±0.012)	2.5±0.20 (0.098±0.008)	1.15±0.10 (0.045±0.004)	F	0.6±0.3 (0.024±0.012)
			1.9±0.20 (0.075±0.008)	N	
□MK432 (1812)	4.5±0.4 (0.177±0.016)	3.2±0.30 (0.126±0.012)	2.5±0.20 (0.098±0.008)	M	0.9±0.6 (0.035±0.024)

Unit : mm (inch)

电容量取值范围 AVAILABLE CAPACITANCE RANGE

电容量 Cap [μF]	类型 Type	107		212		316			325			432		
	温度特性 Temp.Char	B/X7R	B/X7S	B/X7R		B/X7R			B/X7R			B/X7R		
	VDC [pF:3digits]	100V	100V	100V	250V	100V	250V	630V	100V	250V	630V	100V	250V	630V
0.001	102	A			D			F						
0.0015	152	A			D			F						
0.0022	222	A			D			F						
0.0033	332	A			D			F						
0.0047	472	A			G			F						
0.0068	682	A			G			F						
0.01	103	A		G	G			F						
0.015	153	A		G	G			L						
0.022	223	A		G	G			L		N				
0.033	333	A		G			L			N				
0.047	473			G		L	L		N	N				M
0.068	683			G		L	L							M
0.1	104		A	G		L	L		F	N			M	M
0.15	154					L				N				
0.22	224			G		L			N	N				M
0.33	334					L								M
0.47	474					L						M		M
0.68	684								N					
1.0	105						L			N			M	
1.5	155												M	
2.2	225								N				M	

※图表中的字母标记为产品厚度代码。 Letters in the table indicate thickness.

温度特性代码 Temp.char.Code	温度特性 Temperature characteristics					电容量公差 [%] Capacitance tolerance	损耗角正切 tan δ [%] Dissipation factor
	适用标准 Applicable standard		温度范围 [°C] Temperature range	基准温度 [°C] Ref. Temp.	电容量变化率 [%] Capacitance change		
BJ	JIS	B	-25~+85	20	±10	±10(K) ±20(M)	2.5 max.*
	EIA	X5R	-55~+85	25	±15		
B7	EIA	X7R	-55~+125	25	±15		
C7	EIA	X7S	-55~+125	25	+22		

* : 此处数据为代表值。详情请参见型号一览表。

* : The figure indicates typical value. Please refer to PART NUMBERS table.

选件指南
Selection Guide



etc

型号一览
Part Numbers



特性图
Electrical Characteristics



包装
Packaging



可靠性
Reliability Data



使用注意事项
Precautions



■ 107 型 (0603 规格) 107TYPE (0603 case size)

【温度特性 Temp.char. BJ:B/X7R/X7S】

额定电压 Rated Voltage	型号 Ordering code	EHS (Environmental Hazardous Substances)	标称电容量 Capacitance 〔μF〕	温度特性 Temperature characteristics	损耗角正切 tan δ Dissipation factor 〔%〕Max.	焊接方式 Soldering method R:回流焊 Reflow soldering W:波峰焊 Wave soldering	电容量公差 Capacitance tolerance	厚度 Thickness 〔mm〕 〔inch〕
100V	HMK107 BJ102□A	RoHS	0.001	B/X7R**	3.5	R	±10% ±20%	0.8±0.1 (0.031±0.0041)
	HMK107 BJ152□A	RoHS	0.0015					
	HMK107 BJ222□A	RoHS	0.0022					
	HMK107 BJ332□A	RoHS	0.0033					
	HMK107 BJ472□A	RoHS	0.0047					
	HMK107 BJ682□A	RoHS	0.0068					
	HMK107 BJ103□A	RoHS	0.01					
	HMK107 BJ153□A	RoHS	0.015					
	HMK107 BJ223□A	RoHS	0.022					
	HMK107 BJ333□A	RoHS	0.033					
HMK107 BJ104□A	RoHS	0.1	B/X7S**					

** 'X7R', 'X7S' 标有温度特性标记 'BJ'。

**Temperature characteristic signal, BJ is applicable for X7R and X7S.

【温度特性 Temp.char. B7:X7R C7:X7S】

额定电压 Rated Voltage	型号 Ordering code	EHS (Environmental Hazardous Substances)	标称电容量 Capacitance 〔μF〕	温度特性 Temperature characteristics	损耗角正切 tan δ Dissipation factor 〔%〕Max.	焊接方式 Soldering method R:回流焊 Reflow soldering W:波峰焊 Wave soldering	电容量公差 Capacitance tolerance	厚度 Thickness 〔mm〕 〔inch〕
100V	HMK107 B7 102□A	RoHS	0.001	X7R	3.5	R	±10% ±20%	0.8±0.1 (0.031±0.0041)
	HMK107 B7 152□A	RoHS	0.0015					
	HMK107 B7 222□A	RoHS	0.0022					
	HMK107 B7 332□A	RoHS	0.0033					
	HMK107 B7 472□A	RoHS	0.0047					
	HMK107 B7 682□A	RoHS	0.0068					
	HMK107 B7 103□A	RoHS	0.01					
	HMK107 B7 153□A	RoHS	0.015					
	HMK107 B7 223□A	RoHS	0.022					
	HMK107 B7 333□A	RoHS	0.033					
	HMK107 C7 104□A	RoHS	0.1	X7S				

请在型号的□中指定静电容量许容公差标记。

□ Please specify the capacitance tolerance code.

■ 212 型 (0805 规格) 212TYPE (0805 case size)

【温度特性 Temp.char. BJ:B/X7R】

额定电压 Rated Voltage	型号 Ordering code	EHS (Environmental Hazardous Substances)	标称电容量 Capacitance 〔μF〕	温度特性 Temperature characteristics	损耗角正切 tan δ Dissipation factor 〔%〕Max.	焊接方式 Soldering method R:回流焊 Reflow soldering W:波峰焊 Wave soldering	电容量公差 Capacitance tolerance	厚度 Thickness 〔mm〕 〔inch〕
100V	HMK212 BJ103□G	RoHS	0.01	B/X7R**	3.5	R	±10% ±20%	1.25±0.1 (0.049±0.004)
	HMK212 BJ153□G	RoHS	0.015					
	HMK212 BJ223□G	RoHS	0.022					
	HMK212 BJ333□G	RoHS	0.033					
	HMK212 BJ473□G	RoHS	0.047					
	HMK212 BJ683□G	RoHS	0.068					
	HMK212 BJ104□G	RoHS	0.1					
HMK212 BJ224□G	RoHS	0.22						
250V	QMK212 BJ102□D	RoHS	0.001		2.5			0.85±0.1 (0.033±0.004)
	QMK212 BJ152□D	RoHS	0.0015					
	QMK212 BJ222□D	RoHS	0.0022					
	QMK212 BJ332□D	RoHS	0.0033					
	QMK212 BJ472□G	RoHS	0.0047					
	QMK212 BJ682□G	RoHS	0.0068					
	QMK212 BJ103□G	RoHS	0.01					
	QMK212 BJ153□G	RoHS	0.015					
	QMK212 BJ223□G	RoHS	0.022					
	QMK212 BJ223□G	RoHS	0.022	1.25±0.1 (0.049±0.004)				

** 'X7R' 标有温度特性标记 'BJ'。

**Temperature characteristic signal, BJ is applicable for X7R.

【温度特性 Temp.char. B7:X7R】

额定电压 Rated Voltage	型号 Ordering code	EHS (Environmental Hazardous Substances)	标称电容量 Capacitance 〔μF〕	温度特性 Temperature characteristics	损耗角正切 tan δ Dissipation factor 〔%〕Max.	焊接方式 Soldering method R:回流焊 Reflow soldering W:波峰焊 Wave soldering	电容量公差 Capacitance tolerance	厚度 Thickness 〔mm〕 〔inch〕
100V	HMK212 B7103□G	RoHS	0.01	X7R	3.5	R	±10% ±20%	1.25±0.1 (0.049±0.004)
	HMK212 B7153□G	RoHS	0.015					
	HMK212 B7223□G	RoHS	0.022					
	HMK212 B7333□G	RoHS	0.033					
	HMK212 B7473□G	RoHS	0.047					
	HMK212 B7683□G	RoHS	0.068					
	HMK212 B7104□G	RoHS	0.1					
HMK212 B7224□G	RoHS	0.22						
250V	QMK212 B7102□D	RoHS	0.001		2.5			0.85±0.1 (0.033±0.004)
	QMK212 B7152□D	RoHS	0.0015					
	QMK212 B7222□D	RoHS	0.0022					
	QMK212 B7332□D	RoHS	0.0033					
	QMK212 B7472□G	RoHS	0.0047					
	QMK212 B7682□G	RoHS	0.0068					
	QMK212 B7103□G	RoHS	0.01					
	QMK212 B7153□G	RoHS	0.015					
	QMK212 B7223□G	RoHS	0.022					
	QMK212 B7223□G	RoHS	0.022	1.25±0.1 (0.049±0.004)				

请在型号的□中指定静电容量许公差标记。

□ Please specify the capacitance tolerance code.

■ 316 型 (1206 规格) 316TYPE (1206 case size)

【温度特性 Temp.char. BJ:B/X7R】

额定电压 Rated Voltage	型号 Ordering code	EHS (Environmental Hazardous Substances)	标称电容量 Capacitance [μF]	温度特性 Temperature characteristics	损耗角正切 tan δ Dissipation factor [%] Max.	焊接方式 Soldering method R:回流焊 Reflow soldering W:波峰焊 Wave soldering	电容量公差 Capacitance tolerance	厚度 Thickness [mm] (inch)
100V	HMK316 BJ473□L	RoHS	0.047	B/X7R**	3.5	R	±10% ±20%	1.6±0.2 (0.063±0.008)
	HMK316 BJ104□L	RoHS	0.1					
	HMK316 BJ154□L	RoHS	0.15					
	HMK316 BJ224□L	RoHS	0.22					
	HMK316 BJ334□L	RoHS	0.33					
	HMK316 BJ474□L	RoHS	0.47					
HMK316 BJ105□L	RoHS	1						
250V	QMK316 BJ333□L	RoHS	0.033					
	QMK316 BJ473□L	RoHS	0.047					
	QMK316 BJ683□L	RoHS	0.068					
	QMK316 BJ104□L	RoHS	0.1					
630V	SMK316 BJ102□F	RoHS	0.001		2.5			1.15±0.1 (0.045±0.004)
	SMK316 BJ152□F	RoHS	0.0015					
	SMK316 BJ222□F	RoHS	0.0022					
	SMK316 BJ332□F	RoHS	0.0033					
	SMK316 BJ472□F	RoHS	0.0047					
	SMK316 BJ682□F	RoHS	0.0068					
	SMK316 BJ103□F	RoHS	0.01					
	SMK316 BJ153□L	RoHS	0.015					
SMK316 BJ223□L	RoHS	0.022	1.6±0.2 (0.063±0.008)					

** 'X7R' 标有温度特性标记 'BJ'。

**Temperature characteristic signal, BJ is applicable for X7R.

【温度特性 Temp.char. B7:X7R】

额定电压 Rated Voltage	型号 Ordering code	EHS (Environmental Hazardous Substances)	标称电容量 Capacitance [μF]	温度特性 Temperature characteristics	损耗角正切 tan δ Dissipation factor [%] Max.	焊接方式 Soldering method R:回流焊 Reflow soldering W:波峰焊 Wave soldering	电容量公差 Capacitance tolerance	厚度 Thickness [mm] (inch)
100V	HMK316 B7 473□L	RoHS	0.047	X7R	3.5	R	±10% ±20%	1.6±0.2 (0.063±0.008)
	HMK316 B7 104□L	RoHS	0.1					
	HMK316 B7 154□L	RoHS	0.15					
	HMK316 B7 224□L	RoHS	0.22					
	HMK316 B7 334□L	RoHS	0.33					
	HMK316 B7 474□L	RoHS	0.47					
HMK316 B7 105□L	RoHS	1						
250V	QMK316 B7 333□L	RoHS	0.033					
	QMK316 B7 473□L	RoHS	0.047					
	QMK316 B7 683□L	RoHS	0.068					
	QMK316 B7 104□L	RoHS	0.1					
630V	SMK316 B7 102□F	RoHS	0.001		2.5			1.15±0.1 (0.045±0.004)
	SMK316 B7 152□F	RoHS	0.0015					
	SMK316 B7 222□F	RoHS	0.0022					
	SMK316 B7 332□F	RoHS	0.0033					
	SMK316 B7 472□F	RoHS	0.0047					
	SMK316 B7 682□F	RoHS	0.0068					
	SMK316 B7 103□F	RoHS	0.01					
	SMK316 B7 153□L	RoHS	0.015					
SMK316 B7 223□L	RoHS	0.022	1.6±0.2 (0.063±0.008)					

请在型号的□中指定静电容量许容公差标记。

□ Please specify the capacitance tolerance code.

■ 325 型 (1210 规格) 325TYPE (1210 case size)

【温度特性 Temp.char. BJ:B/X7R】

额定电压 Rated Voltage	型号 Ordering code	EHS (Environmental Hazardous Substances)	标称电容量 Capacitance 〔μF〕	温度特性 Temperature characteristics	损耗角正切 tan δ Dissipation factor 〔%〕Max.	焊接方式 Soldering method R:回流焊 Reflow soldering W:波峰焊 Wave soldering	电容量公差 Capacitance tolerance	厚度 Thickness 〔mm〕 (inch)
100V	HMK325 BJ104□F	RoHS	0.1	B/X7R**	3.5	R	±10% ±20%	1.15±0.1 (0.045±0.004)
	HMK325 BJ224□N	RoHS	0.22					
	HMK325 BJ474□N	RoHS	0.47					
	HMK325 BJ684□N	RoHS	0.68					
	HMK325 BJ105□N	RoHS	1					
HMK325 BJ225□N	RoHS	2.2	2.5		1.9±0.2 (0.075±0.008)			
250V	QMK325 BJ473□N	RoHS						0.047
QMK325 BJ104□N	RoHS	0.1						
QMK325 BJ154□N	RoHS	0.15						
QMK325 BJ224□N	RoHS	0.22						
630V	SMK325 BJ223□N	RoHS	0.022					
	SMK325 BJ333□N	RoHS	0.033					
	SMK325 BJ473□N	RoHS	0.047					

** 'X7R' 标有温度特性标记 'BJ' 。

**Temperature characteristic signal, BJ is applicable for X7R.

【温度特性 Temp.char. B7:X7R】

额定电压 Rated Voltage	型号 Ordering code	EHS (Environmental Hazardous Substances)	标称电容量 Capacitance 〔μF〕	温度特性 Temperature characteristics	损耗角正切 tan δ Dissipation factor 〔%〕Max.	焊接方式 Soldering method R:回流焊 Reflow soldering W:波峰焊 Wave soldering	电容量公差 Capacitance tolerance	厚度 Thickness 〔mm〕 (inch)
100V	HMK325 B7 104□F	RoHS	0.1	X7R	3.5	R	±10% ±20%	1.15±0.1 (0.045±0.004)
	HMK325 B7 224□N	RoHS	0.22					
	HMK325 B7 474□N	RoHS	0.47					
	HMK325 B7 684□N	RoHS	0.68					
	HMK325 B7 105□N	RoHS	1					
	HMK325 B7 225□N	RoHS	2.2					2.5
250V	QMK325 B7 473□N	RoHS	0.047					
QMK325 B7 104□N	RoHS	0.1						
QMK325 B7 154□N	RoHS	0.15						
QMK325 B7 224□N	RoHS	0.22						
630V	SMK325 B7 223□N	RoHS	0.022					
SMK325 B7 333□N	RoHS	0.033						
SMK325 B7 473□N	RoHS	0.047						

请在型号的□中指定静电容量许公差标记。

□ Please specify the capacitance tolerance code.

■ 432 型 (1812 规格) 432TYPE (1812 case size)

【温度特性 Temp.char. BJ:B/X7R】

额定电压 Rated Voltage	型号 Ordering code	EHS (Environmental Hazardous Substances)	标称电容量 Capacitance 〔μF〕	温度特性 Temperature characteristics	损耗角正切 tan δ Dissipation factor 〔%〕Max.	焊接方式 Soldering method R:回流焊 Reflow soldering W:波峰焊 Wave soldering	电容量公差 Capacitance tolerance	厚度 Thickness 〔mm〕 〔inch〕
100V	HMK432 BJ474□M	RoHS	0.47	B/X7R**	3.5	R	±10% ±20%	2.5±0.2 (0.098±0.008)
	HMK432 BJ105□M	RoHS	1					
	HMK432 BJ155□M	RoHS	1.5					
	HMK432 BJ225□M	RoHS	2.2					
250V	QMK432 BJ104□M	RoHS	0.1					
	QMK432 BJ224□M	RoHS	0.22					
	QMK432 BJ334□M	RoHS	0.33					
	QMK432 BJ474□M	RoHS	0.47					
630V	SMK432 BJ473□M	RoHS	0.047					
	SMK432 BJ683□M	RoHS	0.068					
	SMK432 BJ104□M	RoHS	0.1					

** 'X7R' 标有温度特性标记 'BJ'。

**Temperature characteristic signal, BJ is applicable for X7R.

【温度特性 Temp.char. B7:X7R】

额定电压 Rated Voltage	型号 Ordering code	EHS (Environmental Hazardous Substances)	标称电容量 Capacitance 〔μF〕	温度特性 Temperature characteristics	损耗角正切 tan δ Dissipation factor 〔%〕Max.	焊接方式 Soldering method R:回流焊 Reflow soldering W:波峰焊 Wave soldering	电容量公差 Capacitance tolerance	厚度 Thickness 〔mm〕 〔inch〕
100V	HMK432 B7474□M	RoHS	0.47	X7R	3.5	R	±10% ±20%	2.5±0.2 (0.098±0.008)
	HMK432 B7105□M	RoHS	1					
	HMK432 B7155□M	RoHS	1.5					
	HMK432 B7225□M	RoHS	2.2					
250V	QMK432 B7104□M	RoHS	0.1					
	QMK432 B7224□M	RoHS	0.22					
	QMK432 B7334□M	RoHS	0.33					
	QMK432 B7474□M	RoHS	0.47					
630V	SMK432 B7473□M	RoHS	0.047					
	SMK432 B7683□M	RoHS	0.068					
	SMK432 B7104□M	RoHS	0.1					

请在型号的□中指定静电容量许容公差标记。

□ Please specify the capacitance tolerance code.

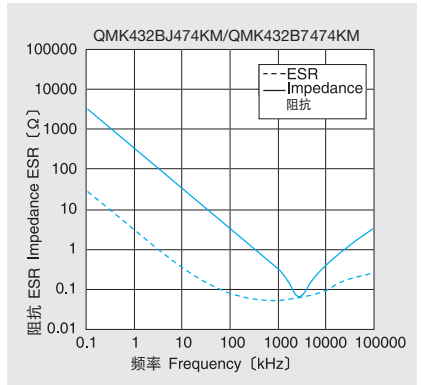
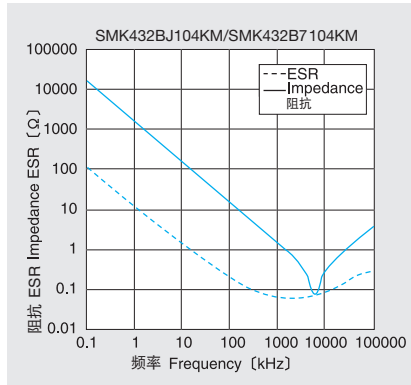
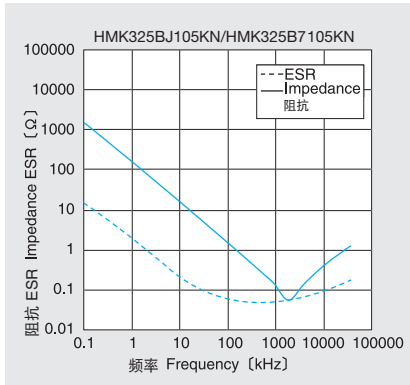
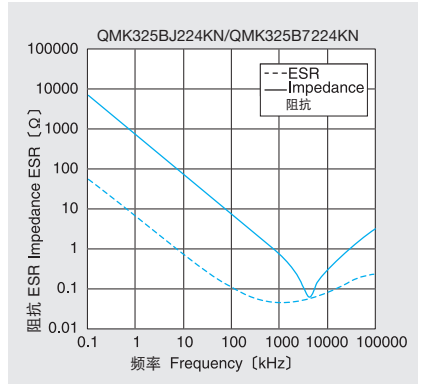
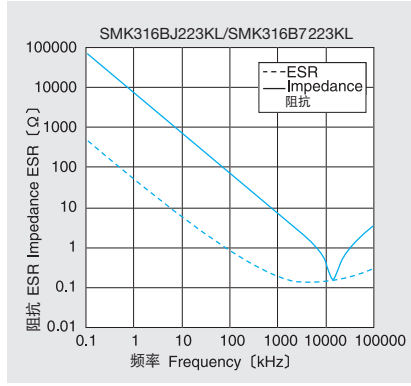
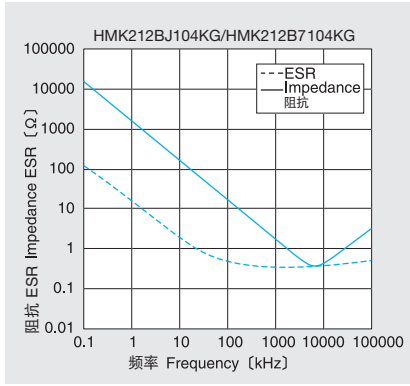

电容量—温度特性 Temperature characteristics

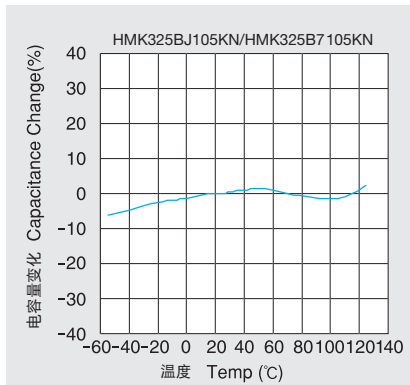

中高耐压多层陶瓷电容器

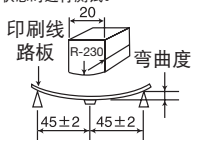
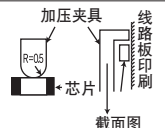
项 目	规 格 值	试验方法·摘要
1.使用温度范围	X7R, X7S: -55~+125°C B: -25~+85°C	
2.保存温度范围	X7R, X7S: -55~+125°C B: -25~+85°C	
3.额定电压	100VDC, 250VDC, 630VDC	
4.耐电压(端子间)	无绝缘损坏或破损	外加电压: 额定电压×2.5(100V) 额定电压×2(250V) 额定电压×1.2(630V) 外加时间: 1~5秒 充放电电流: 50mA以下
5.绝缘阻抗	100MΩ μF或10GΩ, 任一较小值以上	外加电压: 额定电压(100V, 250V)500V(630V) 外加时间: 60±5秒 充放电电流: 50mA以下
6.电容量(公差)	±10%、±20%	测试频率: 1kHz±10% 测试电压: 1±0.2Vrms 外加偏压: 无
7.损耗角正切(tan δ)	3.5%以下(100V) 2.5%以下(250V, 630V)	测试频率: 1kHz±10% 测试电压: 1±0.2Vrms 外加偏压: 无
8.电容温度特性	B: ±10% (-25~+85°C) X7R: ±15% (-55~+125°C) X7S: ±22% (-55~+125°C)	根据JIS 5102规范7.12项。 步骤1~5的最大电容偏差变化 步骤1的温度: +25°C 步骤2的温度: 最低使用温度 步骤3的温度: +25°C(基准温度) 步骤4的温度: 最高使用温度 步骤5的温度: +25°C B特性的基准温度应为+20°C。
9.印刷线路板耐弯曲性	外观: 无异常 电容量变化: ±10%	弯曲量: 1mm 测试印刷线路板: 玻璃基材、环氧树脂线路板 线路板厚度: 1.6mm 在1mm弯曲状态时进行测试。  (单位: mm)
10.端子电极固着力	端子电极无松动及其他不良现象。	加压荷重: 5N 外加时间: 30±5秒 
11.可焊性	端子电极不少于75%的面积覆盖新涂层。	焊锡温度: 230±5°C 浸渍时间: 4±1秒
12.焊接耐热性	外观: 无异常 电容量变化: ±15%以内(100V), ±10%以内(250V, 630V) tan δ: 初期规定值 绝缘阻抗: 初期规定值 耐电压(端子间): 无异常	预处理: 热处理(150°C 1小时) 焊锡温度: 270±5°C 浸渍时间: 3±0.5秒 预热条件: 80~100°C 2~5分钟 150~200°C 2~5分钟 后期处理: 测试后在标准状态下放置24±2小时。
13.温度循环	外观: 无异常 电容量变化: ±15%以内(100V), ±7.5%以内(250V, 630V) tan δ: 初期规定值 绝缘阻抗: 初期规定值	预处理: 热处理(150°C 1小时) 1回循环条件/步骤1: 最低使用温度 \pm_3^0 C 30±3分钟 步骤2: 常温 2~3分钟 步骤3: 最高使用温度 \pm_3^0 C 30±3分钟 步骤4: 常温 2~3分钟 试验次数: 5回 试验后静放时间: 24±2小时

项 目	规 格 值	试验方法·摘要
14.耐湿性(稳态)	外观：无异常 电容量变化：±15%以内 tan δ：7%以下(100V), 5%以下(250V, 630V) 绝缘阻抗：25MΩ μ或1000MΩ, 任一较小值以上	预处理：热处理(150℃ 1小时) 温度：40±2℃ 湿度：90~95%RH 试验时间：500 ⁺²⁴ ₀ 小时 后期处理：从试验容器中取出后, 在标准状态下放置24±2小时。
15.耐湿负载	外观：无异常 电容量变化：±15%以内 tan δ：7%以下(100V), 5%以下(250V, 630V) 绝缘阻抗：10MΩ μ或500MΩ, 任一较小值以上	根据JIS 5102规范9.9项。 预处理：电压处理 温度：40±2℃ 湿度：90~95%RH 外加电压：额定电压 充放电电流：50mA以下 试验时间：500 ⁺²⁴ ₀ 小时 后期处理：从试验容器中取出后, 在标准状态下放置24±2小时
16.高温负载	外观：无异常 电容量变化：±15%以内 tan δ：7%以下(100V), 5%以下(250V, 630V) 绝缘阻抗：50MΩ μ或1000MΩ, 任一较小值以上	根据JIS 5102规范9.10项。 预处理：电压处理 温度：125±3℃(X7R, X7S) 85±2℃(BJ) 外加电压：额定电压×2(100V) 额定电压×1.5(250V) 额定电压×1.2(630V) 充放电电流：50mA以下 试验时间：1000 ⁺²⁴ ₀ 小时 后期处理：从试验容器中取出并经过热处理后, 在标准状态下放置24±2小时。

LW逆转型多层陶瓷电容器 (LWDC)

LW REVERSAL DECOUPLING CAPACITOR (LWDC)

	代码 code	温度特性 Temp.characteristics	使用温度范围 Operating Temp. range
使用温度	BJ	B	-25~+85°C
		X5R	-55~+85°C
OPERATING TEMP.	B7	X7R	-55~+125°C
	C6	X6S	-55~+105°C
	C7	X7S	-55~+125°C



特点 FEATURES

- 低等价串联电阻 (ESR)
- 低等价串联电感值 (ESL)
- 高去除高频噪音效果
- 脉动电压降低
- 实现小型、大容量化

- Low equivalent series resistance (ESR)
- Low equivalent series inductor (ESL)
- The effect of noise removal in the high frequency
- The ripple voltage is decreased
- Small size, High capacitance

用途 APPLICATIONS

- 去耦电容器
- 滤波电容器

- Decoupling capacitors
- Filtering capacitors

型号标示法 ORDERING CODE

1 额定电压 (VDC)	3 端子电极	5 温度特性 (%)	7 电容量公差 (%)	9 个别规格
A 4 J 6.3 L 10 E 16	K 电镀	B J B ±10	K ±10 M ±20	- 标准
2 系列名	4 外形尺寸 (EIA) 长×宽 (mm)	6 标称电容量 (μF)	8 厚度 (mm)	10 包装
W LW逆转型	107 (0603) 1.6×0.8 212 (0805) 2.0×1.25 316 (1206) 3.2×1.6	例 105 1.0 106 10.0	V 0.5 A 0.8 D 0.85	T 带装 (4mm间距·178φ) F 带装 (2mm间距·178φ)
		6 Nominal capacitance (μF)		11 本公司管理记号
		example 105 1.0 106 10.0		△ 标准品 △=空格
J W K 2 1 2 B J 1 0 6 M D - T △				
1 2 3 4 5 6 7 8 9 10 11				

1 Rated voltage (VDC)	3 End termination	5 Temperature characteristics code (%)	7 Capacitance tolerances (%)	9 Special code
A 4 J 6.3 L 10 E 16	K Plated	B7 X7R -55~+125°C ±15% C7 X7S -55~+125°C ±22% C6 X6S -55~+105°C ±22%	K ±10 M ±20	- Standard products
2 Series name	4 Dimensions(case size) (mm)	6 Nominal capacitance (μF)	8 Thickness (mm)	10 Packaging
W LW Reverse Type	105 (0204) 1.0×0.5 107 (0603) 1.6×0.8 212 (0805) 2.0×1.25 316 (1206) 3.2×1.6	example 105 1.0 106 10.0	P 0.3 V 0.5 A 0.8 D 0.85	T Tape (4mm pitch·178φ) F Tape (2mm pitch·178φ)
				11 Internal code
				△ Standard products △=Blank space

外形尺寸 EXTERNAL DIMENSIONS

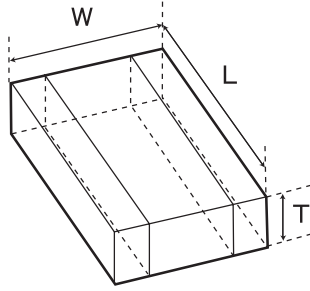

型号 Type (EIA)	长 L	宽 W	端 T	
□WK105 (0204)	1.00±0.05 (0.039±0.002)	0.52±0.05 (0.020±0.002)	P	0.3±0.05 (0.012±0.002)
□WK107 (0306)	1.6±0.10 (0.063±0.004)	0.8±0.10 (0.031±0.004)	V	0.5±0.05 (0.020±0.002)
			A	0.80±0.10 (0.031±0.004)
□WK212 (0508)	2.00±0.15 (0.079±0.006)	1.25±0.15 (0.049±0.006)	D	0.85±0.10 (0.033±0.004)
□WK316 (0612)	3.2±0.15 (0.126±0.006)	1.6±0.15 (0.063±0.006)	D	0.85±0.10 (0.033±0.004)

Unit : mm (inch)

电容量取值范围 AVAILABLE CAPACITANCE RANGE

电容量 Cap [μF]	型号 Type	105		107				212	316
	温度特性 Temp.Char	X7S	X6S	B/X7R	X7R	X7S	X6S	X6S	B/X7R
	VDC [μF:3digits]	6.3	4	10	6.3		4	6.3	16
0.10	104	P							
0.22	224		P		V				
1.0	105			A		V			
2.2	225						V		D
4.7	475							D	
10.0	106							D	

※有色栏目内的数字表示厚度。 Note : Letters in the table indicate thickness.

温度特性代码 Temp.char.Code	温度特性 Temperature characteristics				电容量公差 [%] Capacitance tolerance	损耗角正切 tan δ [%] Dissipation factor	
	适用标准 Applicable standard		温度范围 [°C] Temperature range	基准温度 [°C] Ref. Temp.			电容量变化率 [%] Capacitance change
BJ	JIS	B	-25~+85	20	±10	±10 (K) ±20 (M)	10 max.*
	EIA	X5R	-55~+85	25	±15		
B7	EIA	X7R	-55~+125	25	±15		
C6	EIA	X6S	-55~+105	25	±22		
C7	EIA	X7S	-55~+125	25	±22		

* : 此处数据为代表值。详情请参见型号一览表。

* : The figure indicates typical value. Please refer to PART NUMBERS table.

选件指南
Selection Guide



etc

型号一览
Part Numbers



特性图
Electrical Characteristics



包装
Packaging



可靠性
Reliability Data



使用注意事项
Precautions



型号一览 PART NUMBERS

■ 105 型 (0204 规格) 105TYPE (0204 case size)

【温度特性 Temp.char. BJ:X6S/X7S】

额定电压 Rated Voltage	型号 Ordering code		EHS (Environmental Hazardous Substances)	标称电容量 Capacitance [μ F]	温度特性 Temperature characteristics	损耗角正切 $\tan \delta$ Dissipation factor [%] Max.	焊接方式 Soldering method R:回流焊 Reflow soldering W:波峰焊 Wave soldering	电容量公差 Capacitance tolerance	厚度 Thickness [mm] (inch)
6.3V	JWK105 BJ104MP*		RoHS	0.1	X7S**	5	R	±20% [M]	0.3±0.05 (0.012±0.002)
4V	AWK105 BJ224MP*		RoHS	0.22	X6S**	10			

** 'X6S', 'X7S' 标有温度特性标记 'BJ'。

**Temperature characteristic signal, BJ is applicable for X6S and X7S.

【温度特性 Temp.char. C6:X6S C7:X7S】

额定电压 Rated Voltage	型号 Ordering code		EHS (Environmental Hazardous Substances)	标称电容量 Capacitance [μ F]	温度特性 Temperature characteristics	损耗角正切 $\tan \delta$ Dissipation factor [%] Max.	焊接方式 Soldering method R:回流焊 Reflow soldering W:波峰焊 Wave soldering	电容量公差 Capacitance tolerance	厚度 Thickness [mm] (inch)
6.3V	JWK105 C7 104MP*		RoHS	0.1	X7S	5	R	±20% [M]	0.3±0.05 (0.012±0.002)
4V	AWK105 C6 224MP*		RoHS	0.22	X6S	10			

* 高温负载试验电压为额定电压的 1.5 倍。

* Test Voltage of Loading at high temperature test is 1.5 time of the rated voltage.

■ 107 型 (0306 规格) 107TYPE (0306 case size)

【温度特性 Temp.char. BJ:B/X7R/X7S】

额定电压 Rated Voltage	型号 Ordering code		EHS (Environmental Hazardous Substances)	标称电容量 Capacitance [μ F]	温度特性 Temperature characteristics	损耗角正切 $\tan \delta$ Dissipation factor [%] Max.	焊接方式 Soldering method R:回流焊 Reflow soldering W:波峰焊 Wave soldering	电容量公差 Capacitance tolerance	厚度 Thickness [mm] (inch)
10V	LWK107 BJ105□A*		RoHS	1	B/X7R**	5	R	±10% [K] ±20% [M]	0.8±0.1 (0.031±0.004)
6.3V	JWK107 BJ224MV*		RoHS	0.22	X7R**			10	±20% [M]
	4V	JWK107 BJ105MV*		RoHS	1	X7S**			
		AWK107 BJ225MV*		RoHS	2.2	X7S**			

** 'X7R', 'X7S' 标有温度特性标记 'BJ'。

**Temperature characteristic signal, BJ is applicable for X7R and X7S.

【温度特性 Temp.char. B7:X7R C7:X7S】

额定电压 Rated Voltage	型号 Ordering code		EHS (Environmental Hazardous Substances)	标称电容量 Capacitance [μ F]	温度特性 Temperature characteristics	损耗角正切 $\tan \delta$ Dissipation factor [%] Max.	焊接方式 Soldering method R:回流焊 Reflow soldering W:波峰焊 Wave soldering	电容量公差 Capacitance tolerance	厚度 Thickness [mm] (inch)
10V	LWK107 B7 105□A*		RoHS	1	X7R	5	R	±10% [K] ±20% [M]	0.8±0.1 (0.031±0.004)
6.3V	JWK107 B7 224MV*		RoHS	0.22				X7S	10
	4V	JWK107 C7 105MV*		RoHS	1				
		AWK107 C7 225MV*		RoHS	2.2				

请在型号的□中指定电容量公差代码。

Please specify the capacitance tolerance code.

* 高温负载试验电压为额定电压的 1.5 倍。

* Test Voltage of Loading at high temperature test is 1.5 time of the rated voltage.

■ 212 型 (0508 规格) 212TYPE (0508 case size)

【温度特性 Temp.char. BJ:X6S】

额定电压 Rated Voltage	型号 Ordering code	EHS (Environmental Hazardous Substances)	标称电容量 Capacitance [μ F]	温度特性 Temperature characteristics	损耗角正切 $\tan \delta$ Dissipation factor [%] Max.	焊接方式 Soldering method R:回流焊 Reflow soldering W:波峰焊 Wave soldering	电容量公差 Capacitance tolerance	厚度 Thickness [mm] (inch)
6.3V	JWK212 BJ475□D*	RoHS	4.7	X6S**	10	R	±10% [K] ±20% [M]	0.85±0.1 (0.033±0.004)
	JWK212 BJ106MD*	RoHS	10				±20% [M]	

** 'X6S' 标有温度特性标记 'BJ'。

**Temperature characteristic signal, BJ is applicable for X6S.

【温度特性 Temp.char. C6:X6S】

额定电压 Rated Voltage	型号 Ordering code	EHS (Environmental Hazardous Substances)	标称电容量 Capacitance [μ F]	温度特性 Temperature characteristics	损耗角正切 $\tan \delta$ Dissipation factor [%] Max.	焊接方式 Soldering method R:回流焊 Reflow soldering W:波峰焊 Wave soldering	电容量公差 Capacitance tolerance	厚度 Thickness [mm] (inch)
6.3V	JWK212 C6 475□D*	RoHS	4.7	X6S	10	R	±10% [K] ±20% [M]	0.85±0.1 (0.033±0.004)
	JWK212 C6 106MD*	RoHS	10				±20% [M]	

请在型号的□中指定电容量公差代码。

□ Please specify the capacitance tolerance code.

* 高温负载试验电压为额定电压的 1.5 倍。

* Test Voltage of Loading at high temperature test is 1.5 time of the rated voltage.

■ 316 型 (0612 规格) 316TYPE (0612 case size)

【温度特性 Temp.char. BJ:B/X7R】

额定电压 Rated Voltage	型号 Ordering code	EHS (Environmental Hazardous Substances)	标称电容量 Capacitance [μ F]	温度特性 Temperature characteristics	损耗角正切 $\tan \delta$ Dissipation factor [%] Max.	焊接方式 Soldering method R:回流焊 Reflow soldering W:波峰焊 Wave soldering	电容量公差 Capacitance tolerance	厚度 Thickness [mm] (inch)
16V	EWK316 BJ225□D*	RoHS	2.2	B/X7R**	3.5	R	±10% [K] ±20% [M]	0.85±0.1 (0.033±0.004)

** 'X7R' 标有温度特性标记 'BJ'。

**Temperature characteristic signal, BJ is applicable for X7R.

【温度特性 Temp.char. B7:X7R】

额定电压 Rated Voltage	型号 Ordering code	EHS (Environmental Hazardous Substances)	标称电容量 Capacitance [μ F]	温度特性 Temperature characteristics	损耗角正切 $\tan \delta$ Dissipation factor [%] Max.	焊接方式 Soldering method R:回流焊 Reflow soldering W:波峰焊 Wave soldering	电容量公差 Capacitance tolerance	厚度 Thickness [mm] (inch)
16V	EWK316 B7 225□D*	RoHS	2.2	X7R	3.5	R	±10% [K] ±20% [M]	0.85±0.1 (0.033±0.004)

请在型号的□中指定电容量公差代码。

□ Please specify the capacitance tolerance code.

* 高温负载试验电压为额定电压的 1.5 倍。

* Test Voltage of Loading at high temperature test is 1.5 time of the rated voltage.

特性图 ELECTRICAL CHARACTERISTICS

阻抗· ESR-频率特性例 Example of Impedance ESR vs. Frequency characteristics

· 太阳诱电多层陶瓷电容器例 (Taiyo Yuden multilayer ceramic capacitor)

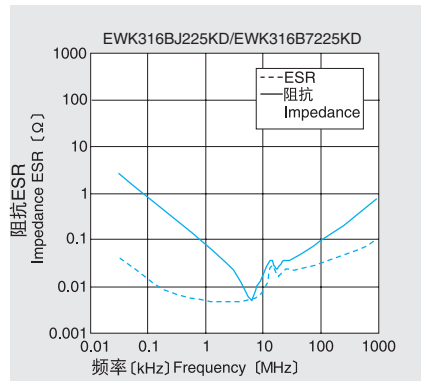
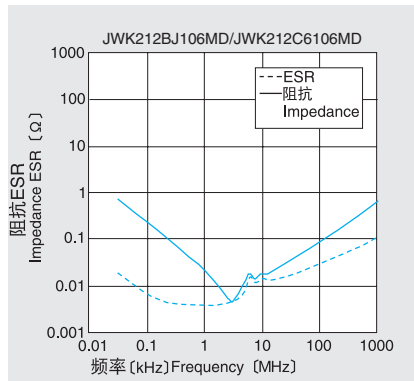
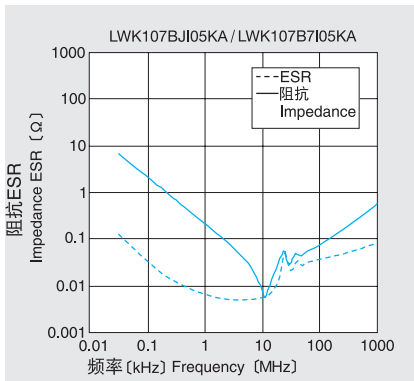

多连型多层陶瓷电容器

ARRAY TYPE MULTILAYER CERAMIC CAPACITOR

	code	Temp.characteristics	Operating Temp. range
使用温度	BJ	B	-25~+85°C
		X5R	-55~+85°C
OPERATING TEMP.	B7	X7R	-55~+125°C
	CH	C0H	-55~+125°C

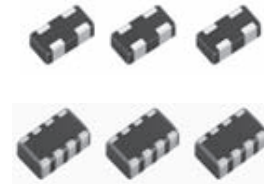

特点 FEATURES

- 采用2125封装形式，内含4个电路，安装密度和效率更高。
- 每个电路的电容值 (F或B介电) 为1 μF，大容量。
- 内部电极采用金属镍，增加了性价比和可靠性。
- 4 circuits in 2125 package allows higher placement density and efficiency
- The capacitance in each circuit, F or B dielectric, is 1 μF
- Internal electrode is nickel for increased cost performance and reliability

用途 APPLICATIONS

- 一般电子设备
- 通讯设备 (手机、PHS、无绳电话等)
- General electronic equipment
- Communication equipment (mobile phone, PHS, cordless phone, etc.)

型号标示法 ORDERING CODE

1 额定电压 (VDC) <table border="1"> <tr><td>J</td><td>6.3</td></tr> <tr><td>L</td><td>10</td></tr> <tr><td>E</td><td>16</td></tr> <tr><td>T</td><td>25</td></tr> <tr><td>U</td><td>50</td></tr> </table>	J	6.3	L	10	E	16	T	25	U	50	3 端接类型 <table border="1"> <tr><td>K</td><td>电镀</td></tr> </table>	K	电镀	5 温度特性 <table border="1"> <tr><td>BJ B</td><td>±10 [%]</td></tr> <tr><td>CH</td><td>0±60 [ppm/°C]</td></tr> </table>	BJ B	±10 [%]	CH	0±60 [ppm/°C]	7 电容公差 <table border="1"> <tr><td>M</td><td>±20 %</td></tr> <tr><td>K</td><td>±10 %</td></tr> <tr><td>F</td><td>±1pF</td></tr> </table>	M	±20 %	K	±10 %	F	±1pF	9 个别规格 <table border="1"> <tr><td>-</td><td>标准品</td></tr> </table>	-	标准品						
J	6.3																																	
L	10																																	
E	16																																	
T	25																																	
U	50																																	
K	电镀																																	
BJ B	±10 [%]																																	
CH	0±60 [ppm/°C]																																	
M	±20 %																																	
K	±10 %																																	
F	±1pF																																	
-	标准品																																	
2 系列名称 <table border="1"> <tr><td>4</td><td>4连型多层电容器</td></tr> <tr><td>2</td><td>2连型多层电容器</td></tr> </table>	4	4连型多层电容器	2	2连型多层电容器	4 外型尺寸 (EIA) 长×宽 (mm) <table border="1"> <tr><td>096 (0302)</td><td>0.9×0.6</td></tr> <tr><td>110 (0504)</td><td>1.4×1.0</td></tr> <tr><td>212 (0805)</td><td>2.0×1.25</td></tr> </table>	096 (0302)	0.9×0.6	110 (0504)	1.4×1.0	212 (0805)	2.0×1.25	6 标称容量 (pF) <table border="1"> <tr><td>例</td><td></td></tr> <tr><td>104</td><td>100,000</td></tr> <tr><td>105</td><td>1,000,000</td></tr> </table>	例		104	100,000	105	1,000,000	8 产品厚度 (mm) <table border="1"> <tr><td>P</td><td>0.3</td></tr> <tr><td>K</td><td>0.45</td></tr> <tr><td>B</td><td>0.6</td></tr> <tr><td>A</td><td>0.8</td></tr> <tr><td>D</td><td>0.85</td></tr> </table>	P	0.3	K	0.45	B	0.6	A	0.8	D	0.85	10 包装 <table border="1"> <tr><td>T</td><td>卷盘带装 (4mm间距·178φ)</td></tr> <tr><td>F</td><td>卷盘带装 (2mm间距·178φ)</td></tr> </table>	T	卷盘带装 (4mm间距·178φ)	F	卷盘带装 (2mm间距·178φ)
4	4连型多层电容器																																	
2	2连型多层电容器																																	
096 (0302)	0.9×0.6																																	
110 (0504)	1.4×1.0																																	
212 (0805)	2.0×1.25																																	
例																																		
104	100,000																																	
105	1,000,000																																	
P	0.3																																	
K	0.45																																	
B	0.6																																	
A	0.8																																	
D	0.85																																	
T	卷盘带装 (4mm间距·178φ)																																	
F	卷盘带装 (2mm间距·178φ)																																	
11 本公司管理记号 <table border="1"> <tr><td>△</td><td>标准品</td></tr> <tr><td>△</td><td>△=空格</td></tr> </table>				△	标准品	△	△=空格																											
△	标准品																																	
△	△=空格																																	

E
4
K
2
1
2
B
J
1
0
4
M
D
-
T
○

1 Rated voltage (VDC) <table border="1"> <tr><td>J</td><td>6.3</td></tr> <tr><td>L</td><td>10</td></tr> <tr><td>E</td><td>16</td></tr> <tr><td>T</td><td>25</td></tr> <tr><td>U</td><td>50</td></tr> </table>	J	6.3	L	10	E	16	T	25	U	50	3 End termination <table border="1"> <tr><td>K</td><td>Plated</td></tr> </table>	K	Plated	5 Temperature characteristics code <table border="1"> <tr><td>B J X5R</td><td>-55~+85°C ±15%</td></tr> <tr><td>B 7 X7R</td><td>-55~+125°C ±15%</td></tr> <tr><td>CH C0H</td><td>0±60[ppm/°C]</td></tr> </table>	B J X5R	-55~+85°C ±15%	B 7 X7R	-55~+125°C ±15%	CH C0H	0±60[ppm/°C]	7 Capacitance tolerances (%) <table border="1"> <tr><td>M</td><td>±20</td></tr> <tr><td>K</td><td>±10</td></tr> <tr><td>F</td><td>±1pF</td></tr> </table>	M	±20	K	±10	F	±1pF	9 Special code <table border="1"> <tr><td>-</td><td>Standard products</td></tr> </table>	-	Standard products				
J	6.3																																	
L	10																																	
E	16																																	
T	25																																	
U	50																																	
K	Plated																																	
B J X5R	-55~+85°C ±15%																																	
B 7 X7R	-55~+125°C ±15%																																	
CH C0H	0±60[ppm/°C]																																	
M	±20																																	
K	±10																																	
F	±1pF																																	
-	Standard products																																	
2 Series name <table border="1"> <tr><td>4</td><td>4 circuit multilayer capacitors</td></tr> <tr><td>2</td><td>2 circuit multilayer capacitors</td></tr> </table>	4	4 circuit multilayer capacitors	2	2 circuit multilayer capacitors	4 Dimensions(case size) (mm) <table border="1"> <tr><td>096 (0302)</td><td>0.9×0.6</td></tr> <tr><td>110 (0504)</td><td>1.4×1.0</td></tr> <tr><td>212 (0805)</td><td>2.0×1.25</td></tr> </table>	096 (0302)	0.9×0.6	110 (0504)	1.4×1.0	212 (0805)	2.0×1.25	6 Nominal capacitance (pF) <table border="1"> <tr><td>example</td><td></td></tr> <tr><td>104</td><td>100,000</td></tr> <tr><td>105</td><td>1,000,000</td></tr> </table>	example		104	100,000	105	1,000,000	8 Thickness (mm) <table border="1"> <tr><td>P</td><td>0.3</td></tr> <tr><td>K</td><td>0.45</td></tr> <tr><td>B</td><td>0.6</td></tr> <tr><td>A</td><td>0.8</td></tr> <tr><td>D</td><td>0.85</td></tr> </table>	P	0.3	K	0.45	B	0.6	A	0.8	D	0.85	10 Packaging <table border="1"> <tr><td>T</td><td>Tape (4mm pitch · 178φ)</td></tr> <tr><td>F</td><td>Tape (2mm pitch · 178φ)</td></tr> </table>	T	Tape (4mm pitch · 178φ)	F	Tape (2mm pitch · 178φ)
4	4 circuit multilayer capacitors																																	
2	2 circuit multilayer capacitors																																	
096 (0302)	0.9×0.6																																	
110 (0504)	1.4×1.0																																	
212 (0805)	2.0×1.25																																	
example																																		
104	100,000																																	
105	1,000,000																																	
P	0.3																																	
K	0.45																																	
B	0.6																																	
A	0.8																																	
D	0.85																																	
T	Tape (4mm pitch · 178φ)																																	
F	Tape (2mm pitch · 178φ)																																	
11 Internal code <table border="1"> <tr><td>△</td><td>Standard products</td></tr> <tr><td>△</td><td>△=Blank space</td></tr> </table>				△	Standard products	△	△=Blank space																											
△	Standard products																																	
△	△=Blank space																																	

外型尺寸 EXTERNAL DIMENSIONS

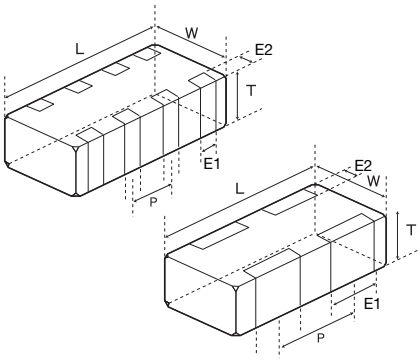

类型Type (EIA)	长 L	宽 W	E1	E2	间距 P	厚 T	
□2K096 (0302)	0.9±0.05 (0.035±0.002)	0.6±0.05 (0.024±0.002)	0.23±0.10 (0.009±0.004)	0.125±0.075 (0.005±0.003)	0.45±0.05 (0.018±0.002)	P	0.30±0.03 (0.012±0.001)
						K	0.45±0.05 (0.018±0.002)
□2K110 (0504)	1.37±0.07 (0.054±0.003)	1.00±0.08 (0.039±0.003)	0.36±0.10 (0.014±0.004)	0.20±0.10 (0.008±0.004)	0.64±0.10 (0.025±0.004)	V	0.5±0.05 (0.020±0.002)
						B	0.60±0.06 (0.024±0.003)
						A	0.80±0.08 (0.031±0.003)
□4K212 (0805)	2.00±0.10 (0.079±0.004)	1.25±0.10 (0.049±0.004)	0.25±0.10 (0.010±0.004)	0.25±0.15 (0.010±0.006)	0.50±0.10 (0.020±0.004)	D	0.85±0.10 (0.033±0.004)
□2K212 (0805)	2.00±0.10 (0.079±0.004)	1.25±0.10 (0.049±0.004)	0.50±0.20 (0.020±0.008)	0.25±0.15 (0.010±0.006)	1.00±0.10 (0.039±0.004)	D	0.85±0.10 (0.033±0.004)

Unit : mm (inch)

电容量取值范围 AVAILABLE CAPACITANCE RANGE

BJ/ X7R, BJ/ X5R

Cap [μF]	类型Type Temp.Char VDC	0906 2连型 □2K096				1410 2连型 □2K110				2125 2连型 □2K212		2125 4连型 □4K212				
		B/X5R	X5R	B/X7R	X5R	B/X5R	X5R	B/X5R	X5R	B/X7R	B/X5R	X5R				
		10V	6.3V	50V	25V	16V	25V	10V	10V	6.3V	25V	10V	16V	25V	10V	10V
0.001	102			B												
0.0022	222			B												
0.0047	472			B												
0.01	103	P		B												
0.022	223			B												
0.047	473		K		B											
0.1	104		K		B	B						D	D			
0.22	224		K				B							D		
0.47	474						A							D		
1.0	105							A	V	D						D
2.2	225								A		D					

※图表中的字母标记为产品厚度代码。 Letters in the table indicate thickness.

CH / C0H

电容量 Cap [pF]	类型Type Temp.Char VDC	0906 2连型 □2K096		1410 2连型 □2K110	
		CH / C0H	CH / C0H	CH / C0H	CH / C0H
		25V	50V	25V	50V
10	100	P	B		
12	120	P	B		
15	150	P	B		
18	180	P	B		
22	220	P	B		
27	270	P	B		
33	330	P	B		
39	390	P	B		
47	470	P	B		
56	560	P	B		
68	680	P	B		
82	820	P	B		
100	101	P	B		

※图表中的字母标记为产品厚度代码。 Letters in the table indicate thickness.

温度特性代码 Temp.char.Code	温度特性 Temperature characteristics				电容量公差 [%] Capacitance tolerance	损耗角正切 tan δ [%] Dissipation factor
	适用标准 Applicable standard	温度范围 [°C] Temperature range	基准温度 [°C] Ref. Temp.	电容量变化率 [%] Capacitance change		
BJ	JIS	B	-25~+85	20	±10 (K) ±20 (M)	3.5, 5, 10 max.*
	EIA	X5R	-55~+85	25		
B7	EIA	X7R	-55~+125	25	±15 [%]	
CH	JIS	CH	-55~+125	20	±60 [ppm/°C]	0.1 max.**
	EIA	C0H	-55~+125	25	±60 [ppm/°C]	

* : 因型号不同, 产品也有所不同。请参见型号一览表。

** : 27pF以下 Q≥400+20·C 30pF以上 Q≥1000

* : Different depending on the item. Please refer to the part numbers list for the differences.

** : 27pF or over Q≥400+20·C 30pF or over Q≥1000

选件指南
Selection Guide



型号一览
Part Numbers



特性图
Electrical Characteristics



包装
Packaging



可靠性
Reliability Data



使用注意事项
Precautions



■ 0906 型 (0302 规格) 2 连型 0906TYPE (0302 case size) (2 circuit type)

【温度特性 Temp.char. BJ:B/X5R】

额定电压 Rated Voltage	型号 Ordering code	EHS (Environmental Hazardous Substances)	标称电容量 Capacitance [μ F]	温度特性 Temperature characteristics	损耗角正切 $\tan \delta$ Dissipation factor [%] Max.	焊接方式 Soldering method R:回流焊 Reflow soldering W:波峰焊 Wave soldering	电容量公差 Capacitance tolerance	厚度 Thickness [mm] (inch)
10V	L2K096 BJ103□P	RoHS	0.01	B/X5R	5	R	±10% [K] ±20% [M]	0.3±0.03 (0.012±0.001)
6.3V	J2K096 BJ473□K*	RoHS	0.047	X5R				10
	J2K096 BJ104□K*	RoHS	0.1		±20% [M]			
	J2K096 BJ224MK*	RoHS	0.22		±20% [M]			

【温度特性 Temp.char. CH:CH/COH】

额定电压 Rated Voltage	型号 Ordering code	EHS (Environmental Hazardous Substances)	标称电容量 Capacitance [pF]	温度特性 Temperature characteristics	损耗角正切 $\tan \delta$ Dissipation factor [%] Max.	焊接方式 Soldering method R:回流焊 Reflow soldering W:波峰焊 Wave soldering	电容量公差 Capacitance tolerance	厚度 Thickness [mm] (inch)
25V	T2K096 CH100FP	RoHS	10	CH/COH	400+20·C	R	±1pF [F]	0.3±0.03 (0.012±0.001)
	T2K096 CH120KP	RoHS	12					
	T2K096 CH150KP	RoHS	15					
	T2K096 CH180KP	RoHS	18					
	T2K096 CH220KP	RoHS	22					
	T2K096 CH270KP	RoHS	27					
	T2K096 CH330KP	RoHS	33					
	T2K096 CH390KP	RoHS	39	1000(0.1%)				
	T2K096 CH470KP	RoHS	47					
	T2K096 CH560KP	RoHS	56					
	T2K096 CH680KP	RoHS	68					
	T2K096 CH820KP	RoHS	82					
	T2K096 CH101KP	RoHS	100					

请在型号的□中指定电容量公差代码。

Please specify the capacitance tolerance code.

* 高温负载试验电压为额定电压的 1.5 倍。

* Test Voltage of Loading at high temperature test is 1.5 time of the rated voltage.

■ 1410 型 (0504 规格) 2 连型 1410TYPE (0504 case size) (2 circuit type)

【温度特性 Temp.char. BJ:B/X5R】

额定电压 Rated Voltage	型号 Ordering code	EHS (Environmental Hazardous Substances)	标称电容量 Capacitance 〔μF〕	温度特性 Temperature characteristics	损耗角正切 tan δ Dissipation factor 〔%〕Max.	焊接方式 Soldering method R:回流焊 Reflow soldering W:波峰焊 Wave soldering	电容量公差 Capacitance tolerance	厚度 Thickness 〔mm〕 〔inch〕
50V	U2K110 BJ102□B	RoHS	0.001	B/X5R**	3.5	R	±10% [K] ±20% [M]	0.6±0.06 (0.024±0.002)
	U2K110 BJ222□B	RoHS	0.0022					
	U2K110 BJ472□B	RoHS	0.0047					
25V	T2K110 BJ103□B	RoHS	0.01					
	T2K110 BJ223□B	RoHS	0.022					
	T2K110 BJ104□B	RoHS	0.1					
16V	E2K110 BJ473□B	RoHS	0.047	B/X5R**	3.5			
	E2K110 BJ104□B	RoHS	0.1					
10V	L2K110 BJ224□B	RoHS	0.22	B/X5R	5			
	L2K110 BJ474□A	RoHS	0.47					
	L2K110 BJ105□A*	RoHS	1.0					
6.3V	J2K110 BJ105□V*	RoHS	1.0	X5R	10			
	J2K110 BJ225□A*	RoHS	2.2					

**因个别规格约定, 将提供X7R规格对应的说明书。

**We may provide X7R for some items according to the individual specification.

【温度特性 Temp.char. B7:X7R】

额定电压 Rated Voltage	型号 Ordering code	EHS (Environmental Hazardous Substances)	标称电容量 Capacitance 〔μF〕	温度特性 Temperature characteristics	损耗角正切 tan δ Dissipation factor 〔%〕Max.	焊接方式 Soldering method R:回流焊 Reflow soldering W:波峰焊 Wave soldering	电容量公差 Capacitance tolerance	厚度 Thickness 〔mm〕 〔inch〕
50V	U2K110 B7 102□B	RoHS	0.001	X7R	3.5	R	±10% [K] ±20% [M]	0.6±0.06 (0.024±0.002)
	U2K110 B7 222□B	RoHS	0.0022					
	U2K110 B7 472□B	RoHS	0.0047					
25V	T2K110 B7 103□B	RoHS	0.01					
	T2K110 B7 223□B	RoHS	0.022					
16V	E2K110 B7 473□B	RoHS	0.047	5				
	E2K110 B7 104□B	RoHS	0.1					

【温度特性 Temp.char. CH:CH/COH】

额定电压 Rated Voltage	型号 Ordering code	EHS (Environmental Hazardous Substances)	标称电容量 Capacitance 〔pF〕	温度特性 Temperature characteristics	损耗角正切 tan δ Dissipation factor 〔%〕Max.	焊接方式 Soldering method R:回流焊 Reflow soldering W:波峰焊 Wave soldering	电容量公差 Capacitance tolerance	厚度 Thickness 〔mm〕 〔inch〕
50V	U2K110 CH100FB	RoHS	10	CH/COH	400+20·C	R	±10% [K]	0.6±0.06 (0.024±0.002)
	U2K110 CH120KB	RoHS	12					
	U2K110 CH150KB	RoHS	15					
	U2K110 CH180KB	RoHS	18					
	U2K110 CH220KB	RoHS	22					
	U2K110 CH270KB	RoHS	27					
	U2K110 CH330KB	RoHS	33		1000 (0.1%)			
	U2K110 CH390KB	RoHS	39					
	U2K110 CH470KB	RoHS	47					
	U2K110 CH560KB	RoHS	56					
	U2K110 CH680KB	RoHS	68					
	U2K110 CH820KB	RoHS	82					
	U2K110 CH101KB	RoHS	100					

请在型号的□中指定电容量公差代码。

□ Please specify the capacitance tolerance code.

* 高温负载试验电压为额定电压的 1.5 倍。

* Test Voltage of Loading at high temperature test is 1.5 time of the rated voltage.

■ 2012 型 (0805 规格) 4 连型 2012TYPE (0805 case size) (4 circuit type)

【温度特性 Temp.char. BJ:B/X5R】

额定电压 Rated Voltage	型号 Ordering code		EHS (Environmental Hazardous Substances)	标称电容量 Capacitance 〔μF〕	温度特性 Temperature characteristics	损耗角正切 tan δ Dissipation factor 〔%〕Max.	焊接方式 Soldering method R:回流焊 Reflow soldering W:波峰焊 Wave soldering	电容量公差 Capacitance tolerance	厚度 Thickness 〔mm〕 (inch)
25V	T4K212 BJ104□D		RoHS	0.1	B/X5R	5	R	±10%〔K〕 ±20%〔M〕	0.85±0.1 (0.033±0.004)
16V	E4K212 BJ104□D		RoHS	0.1	B/X5R**				
10V	L4K212 BJ224□D		RoHS	0.22	B/X5R				
	L4K212 BJ474□D		RoHS	0.47					
	L4K212 BJ105□D*		RoHS	1	X5R	10			

**因个别规格约定，将提供X7R规格对应的说明书。

**We may provide X7R for some items according to the individual specification.

【温度特性 Temp.char. B7:X7R】

额定电压 Rated Voltage	型号 Ordering code		EHS (Environmental Hazardous Substances)	标称电容量 Capacitance 〔μF〕	温度特性 Temperature characteristics	损耗角正切 tan δ Dissipation factor 〔%〕Max.	焊接方式 Soldering method R:回流焊 Reflow soldering W:波峰焊 Wave soldering	电容量公差 Capacitance tolerance	厚度 Thickness 〔mm〕 (inch)
16V	E4K212 B7 104□D		RoHS	0.1	X7R	5	R	±10%〔K〕 ±20%〔M〕	0.85±0.1 (0.033±0.004)

■ 2012 型 (0805 规格) 2 连型 2012TYPE (0805 case size) (2 circuit type)

【温度特性 Temp.char. BJ:B/X5R】

额定电压 Rated Voltage	型号 Ordering code		EHS (Environmental Hazardous Substances)	标称电容量 Capacitance 〔μF〕	温度特性 Temperature characteristics	损耗角正切 tan δ Dissipation factor 〔%〕Max.	焊接方式 Soldering method R:回流焊 Reflow soldering W:波峰焊 Wave soldering	电容量公差 Capacitance tolerance	厚度 Thickness 〔mm〕 (inch)
25V	T2K212 BJ105□D		RoHS	1.0	B/X5R	5	R	±10%〔K〕 ±20%〔M〕	0.85±0.1 (0.033±0.004)
10V	L2K212 BJ225MD*		RoHS	2.2	X5R	10			

请在型号的□中指定电容量公差代码。

Please specify the capacitance tolerance code.

* 高温负载试验电压为额定电压的 1.5 倍。

* Test Voltage of Loading at high temperature test is 1.5 time of the rated voltage.

阻抗 · ESR-频率特性例 Example of Impedance ESR vs. Frequency characteristics
 · 太阳诱电多层陶瓷电容器例 (Taiyo Yuden multilayer ceramic capacitor)

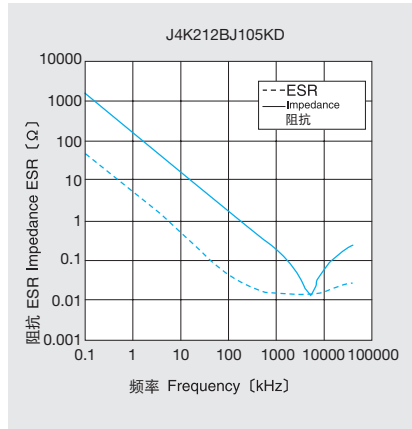
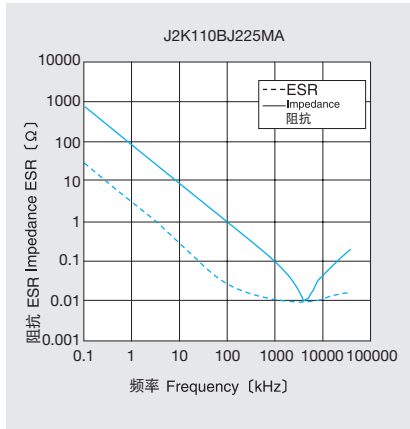
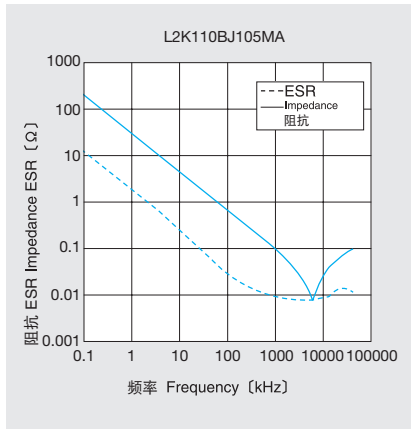
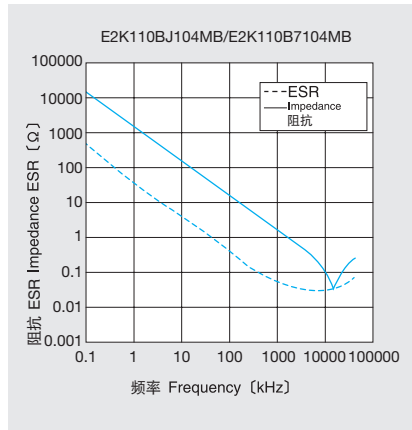
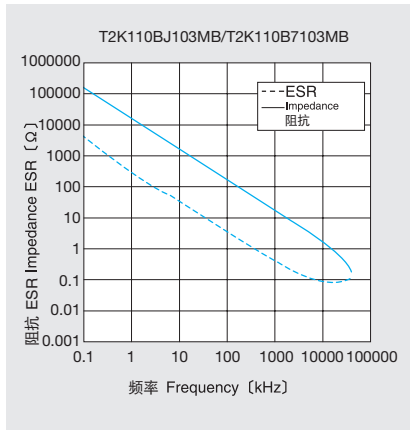
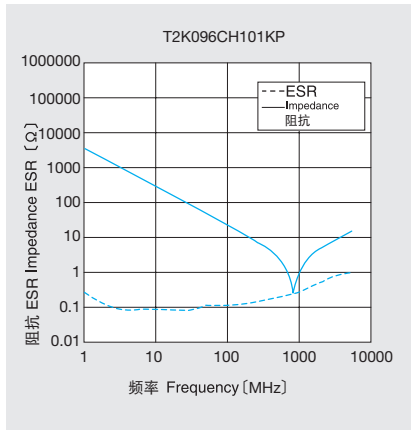
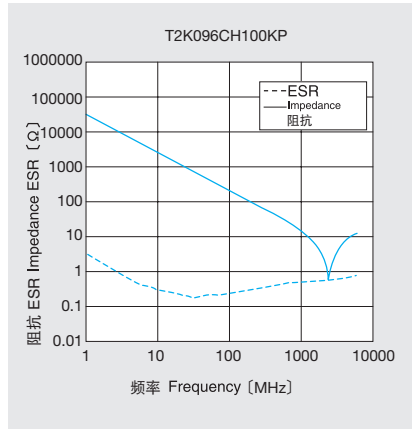
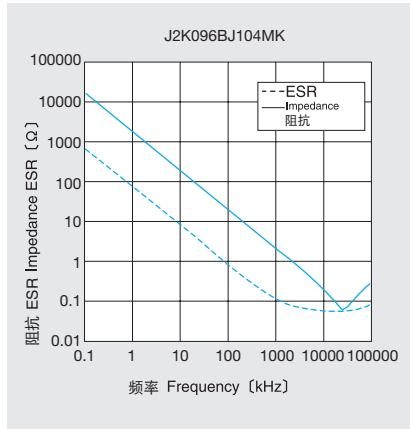
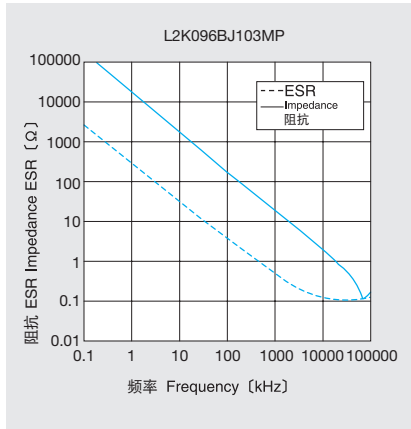

包装 PACKAGING

①最小订货单位数量 Minimum Quantity

■带装 Taped packaging

型号(EIA) Type	产品厚度 Thickness		标准数量 Standard quantity [pcs]	
	mm(inch)	code	纸带 paper	压纹带 Embossed tape
□MK042(01005)	0.2(0.008)	C	15000	—
□MK063(0201)	0.3(0.012)	P	15000	—
□2K096(0302)	0.3(0.012)	P	10000	—
	0.45(0.018)	K		
□WK105(0204)	0.3(0.012)	P	10000	—
□MK105(0402)	0.5(0.020)	V, W	10000	—
□VK105(0402)		W		
□MK107(0603)	0.45(0.018)	K	4000	—
		V		
□WK107(0306)	0.5(0.020)	V	—	4000
		A	4000	—
□2K110(0504)	0.8(0.031)	Z	4000	—
		V		
□MK212(0805)	0.85(0.033)	A	4000	—
		B		
□WK212(0508)	0.45(0.018)	K	4000	—
		D		
□4K212(0805)	0.85(0.033)	D	4000	—
		D		
□2K212(0805)	0.85(0.033)	D	4000	—
		D		
□MK316(1206)	1.25(0.049)	G	—	3000
		F	—	3000
□WK316(0612)	0.85(0.033)	D	4000	—
		D		
□MK325(1210)	1.15(0.045)	F	—	2000
		H		
□MK432(1812)	1.5(0.059)	N	—	2000
		Y		
□MK316(1206)	1.25(0.049)	G	—	3000
		L		
□MK316(1206)	1.6(0.063)	L	—	2000
		D		
□MK316(1206)	1.15(0.045)	F	—	2000
		H		
□MK316(1206)	1.5(0.059)	N	—	2000
		Y		
□MK316(1206)	2.0max(0.079)	Y	—	2000
		M		
□MK316(1206)	2.5(0.098)	M	—	500,1000
		M		

②带装材质 Taping material

※压模袋型无底胶

纸带

Card board carrier tape

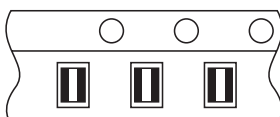
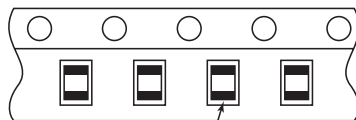
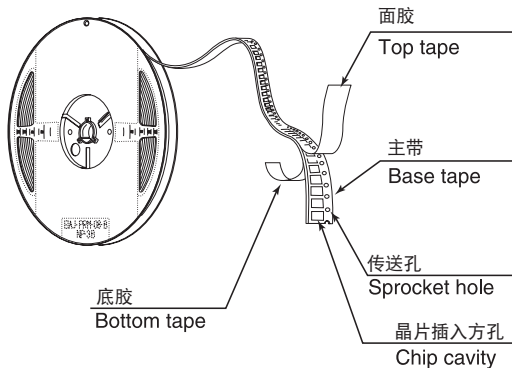

※□WK

压纹带
Embossed Tape

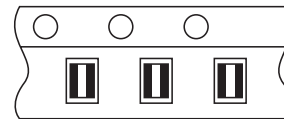
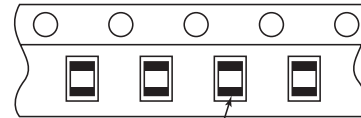
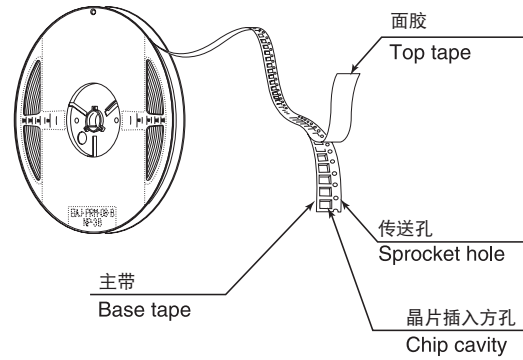

※□WK

③散装盒 Bulk Cassette

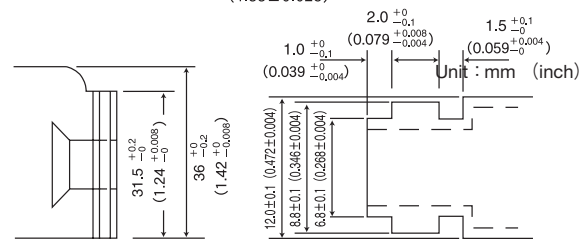
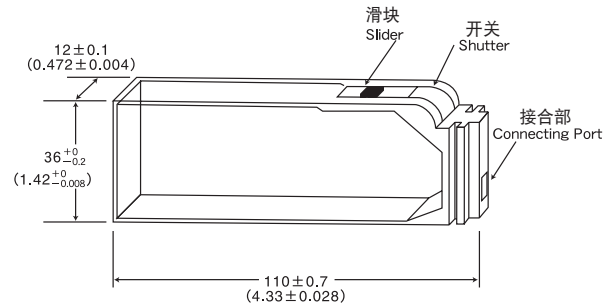

分别按105, 107, 212形状接受订货, 敬请咨询。

Please contact any of our offices for accepting your requirement according to dimensions 0402, 0603, 0805.(inch)

③ 编带尺寸 Taping dimensions
纸带 Paper Tape (8mm宽) (0.315inches wide)

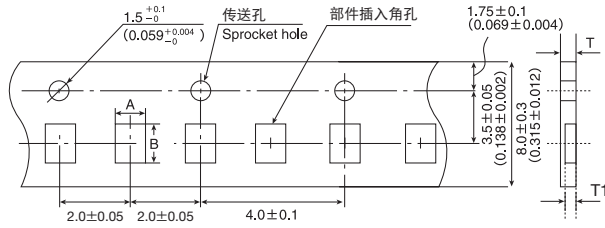

类型 Type (EIA)	晶片插入方孔 Chip Cavity		插入间距 Insertion Pitch F	带厚 Tape Thickness	
	A	B		T	T ₁
□MK042 (01005)	0.25 (0.010)	0.45 (0.018)	2.0±0.05 (0.079±0.002)	0.36max. (0.014)	0.27max. (0.011)
□MK063 (0201)	0.37 (0.016)	0.67 (0.027)	2.0±0.05 (0.079±0.002)	0.45max. (0.018)	0.42max. (0.017)
□WK105 (0204)	0.65 (0.026)	1.15 (0.045)	2.0±0.05 (0.079±0.002)	0.45max. (0.018max)	0.42max. (0.017max)

Unit : mm (inch)

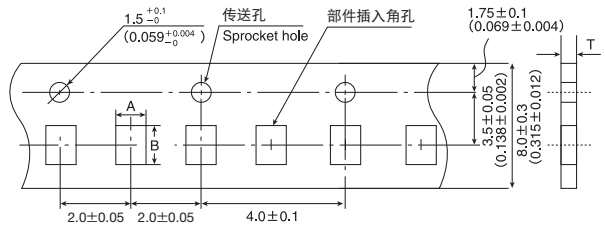

类型 Type (EIA)	晶片插入方孔 Chip Cavity		插入间距 Insertion Pitch F	带厚 Tape Thickness	
	A	B		T	T ₁
□2K096 (0302)	0.72 (0.028)	1.02 (0.040)	2.0±0.05 (0.079±0.002)	0.45max.(0.018max)	0.6max.(0.024max)
□MK105 (0402)	0.65 (0.026)	1.15 (0.045)	2.0±0.05 (0.079±0.002)	0.8max. (0.031max.)	
□VK105 (0402)	0.65 (0.026)	1.15 (0.045)	2.0±0.05 (0.079±0.002)	0.8max. (0.031max.)	

Unit : mm (inch)

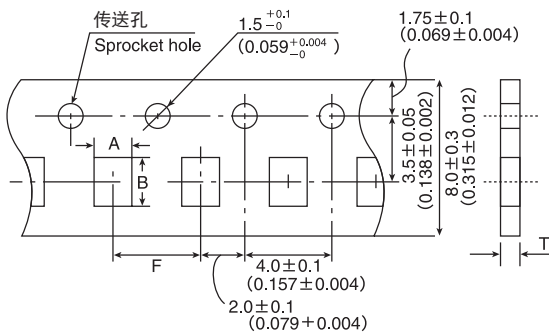

类型 Type (EIA)	晶片插入方孔 Chip Cavity		插入间距 Insertion Pitch F	带厚 Tape Thickness	
	A	B		T	T ₁
□MK107 (0603)	1.0	1.8	4.0±0.1	1.1max.	
□WK107 (0306)	(0.039)	(0.071)	(0.157±0.004)	(0.043max.)	
□2K110 (0504)	1.15 (0.045)	1.55 (0.061)	4.0±0.1 (0.157±0.004)	1.0max. (0.039max.)	
□MK212 (0805)	1.65 (0.065)	2.4 (0.094)	4.0±0.1 (0.157±0.004)	1.1max. (0.043max.)	
□WK212 (0508)					
□4K212 (0805)	2.0 (0.079)	3.6 (0.142)	4.0±0.1 (0.157±0.004)	1.1max. (0.043max.)	
□2K212 (0805)					
□MK316 (1206)					
□WK316 (0612)	2.0 (0.079)	3.6 (0.142)	4.0±0.1 (0.157±0.004)	1.1max. (0.043max.)	

Unit : mm (inch)

压印带 Embossed tape (8mm宽) (0.315inches wide)

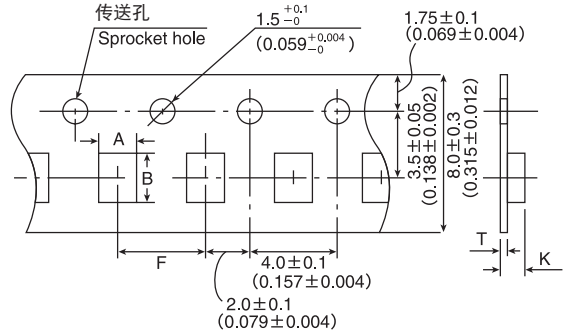

类型 Type (EIA)	晶片插入方孔 Chip cavity		插入间距 Insertion Pitch F	带厚 Tape Thickness	
	A	B		K	T
□WK107 (0306)	1.0 (0.039)	1.8 (0.071)	4.0±0.1 (0.157±0.004)	1.3max. (0.051max.)	0.25±0.1 (0.01±0.004)
□MK212 (0805)	1.65 (0.065)	2.4 (0.094)		3.4max. (0.134max.)	0.6max. (0.024max.)
□MK316 (1206)	2.0 (0.079)	3.6 (0.142)	4.0±0.1 (0.157±0.004)	3.4max. (0.134max.)	0.6max. (0.024max.)
□MK325 (1210)	2.8 (0.110)	3.6 (0.142)		3.4max. (0.134max.)	0.6max. (0.024max.)

Unit : mm (inch)

压印带 Embossed tape (12mm宽) (0.472inches wide)

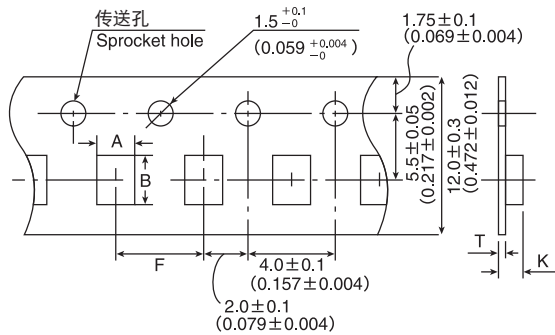

类型 Type (EIA)	晶片插入方孔 Chip cavity		插入间距 Insertion Pitch F	带厚 Tape Thickness	
	A	B		K	T
□MK432 (1812)	3.7 (0.146)	4.9 (0.193)	8.0±0.1 (0.315±0.004)	4.0max. (0.157max.)	0.6max. (0.024max.)

Unit : mm (inch)

④引带/空白部分 Leader and Blank portion

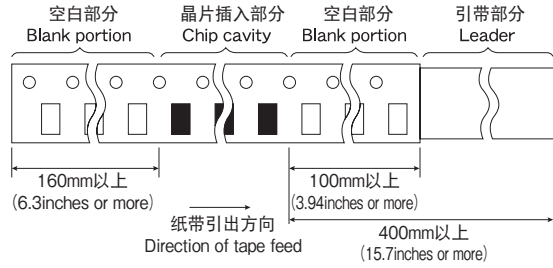

⑤卷盘尺寸 Reel size

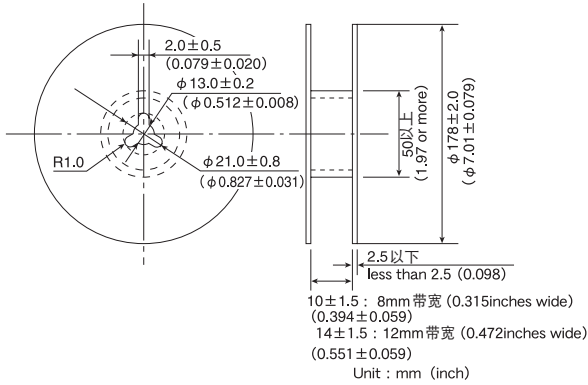

⑥面胶强度 Top Tape Strength

面胶的剥离力应在0.1~0.7N以内，其方向如下图所示。
The top tape requires a peel-off force of 0.1~0.7N in the direction of the arrow as illustrated below.

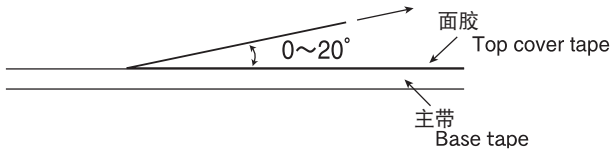

多层陶瓷电容器

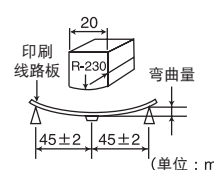
项 目	规 格 值				试验方法·摘要
	温度补偿用 (1类)		高介电常数 (2类)		
	普通用	高频用	普通用 注1	大容量用	
1.使用温度范围	-55~+125℃		BJ: -55~+125℃ F: -25~+85℃	-25~+85℃	但大容量用 BJ (X7R): -55~+125℃, BJ (X5R): -55~+85℃ E (Y5U): -30~+85℃, F (Y5V): -30~+85℃
2.保存温度范围	-55~+125℃		BJ: -55~+125℃ F: -25~+85℃	-25~+85℃	但大容量用 BJ (X7R): -55~+125℃, BJ (X5R): -55~+85℃ E (Y5U): -30~+85℃, F (Y5V): -30~+85℃
3.额定电压	50VDC、25VDC、 16VDC	16VDC 50VDC	50VDC、25VDC	50VDC、35VDC、25VDC、 16VDC、10VDC、6.3VDC、 4VDC、2.5VDC	
4.耐电压 (端子间)	无击穿或破损	无异常	无击穿或破损		外加电压: 额定电压×3 (1类) 额定电压×2.5 (2类) 外加时间: 1~5秒 充放电电流: 50mA以下 (1、2类)
5.绝缘阻抗	10000MΩ以上		500MΩ μF或10000MΩ, 任一较小值以上 注5		外加电压: 额定电压 外加时间: 60±5秒 充放电电流: 50mA以下
6.电容量 (公差)	0.5~5pF: ±0.25pF 1~10pF: ±0.5pF 5~10pF: ±1pF 11pF以上: ±5%, ±10% 105型仅对应RΔ、SΔ、TΔ、UΔ 0.5~2pF: ±0.1pF 2.2~20pF: ±5%	0.5~2pF: ±0.1pF 2.2~5.1pF: ±5%	BJ: ±10%、±20% F: +80% -20%	BJ: ±10%、±20% F: -20%/+80%	测试频率: 1类: 1MHz±10% (C≤1000pF) 1 k Hz±10% (C>1000pF) 2类: 1 k Hz±10% (C≤10 μF) 120Hz±10Hz (C>10 μF) 测试电压: 1类: 0.5~5Vrms (C≤1000pF) 1±0.2Vrms (C>1000pF) 注4: 1±0.2Vrms (C≤10 μF) 0.5±0.1Vrms (C>10 μF) 外加偏压: 无
7.Q值或损耗角正切 (tan δ)	30pF以下: Q≥400+20C 30pF以上: Q≥1000 C: 标称电容量	参照个别规格	BJ: 小于 2.5% (50V、25V) F: 小于 5.0% (50V、25V) 注4	BJ: 2.5%以下 F: 7%以下 注4	多层型: 测试频率: 1类: 1MHz±10% (C≤1000pF) 1 k Hz±10% (C>1000pF) 2类: 1 k Hz±10% (C≤10 μF) 120Hz±10Hz (C>10 μF) 测试电压: 1类: 0.5~5Vrms (C≤1000pF) 1±0.2Vrms (C>1000pF) 注4: 1±0.2Vrms (C≤10 μF) 0.5±0.1Vrms (C>10 μF) 外加偏压: 无 高频多层型 测试频率: 1GHz 测试仪器: HP4291A 测试夹具: HP16192A
8.电容量温度特性	无外加电压 CK: 0±250 CJ: 0±120 CH: 0±60 CG: 0±30 RH: -220±60 SK: -330±250 SJ: -330±120 SH: -330±60 TK: -470±250 TJ: -470±120 UK: -750±250 UJ: -750±120 SL: +350~-1000 (ppm/℃)	CH: 0±60 RH: -220±60 (ppm/℃)	BJ: ±10% (-25~85℃) F: +30% -80% (-25~85℃) BJ (X7R): ±15% F (Y5V): +22% -82%	BJ: ±10% (-25~+85℃) F: +30%/ -80% (-25~+85℃) BJ (X7R、X5R): ±15% F (Y5V): +22%/ -82%	根据 JIS C 5102规范7.12项。 温度补偿用: 测试20℃和85℃的电容量, 并代入以下公式计算。 $\frac{(C_{85}-C_{20})}{C_{20}} \times 10^6 \text{ (ppm/℃)}$ 高介电常数: 步骤1~5的最大电容量偏差变化 步骤1的温度: +20℃ 步骤2的温度: 最低使用温度 步骤3的温度: +20℃ (基准温度) 步骤4的温度: 最高使用温度 步骤5的温度: +20℃ X7R、X5R、Y5U和Y5V的基准温度应为+25℃。
9.印刷线路板耐弯曲性	外观: 无异常 电容量变化: ±5%或±0.5pF, 任一较大值以内。	外观: 无异常 电容量变化: ±0.5pF以内	外观: 无异常 电容量变化: BJ: ±12.5%以内 F: ±30%以内	外观: 无异常 电容量变化: BJ: ±12.5%以内 F: ±30%以内	弯曲量: 1mm 试验印刷线路板 线路板厚度: 1.6mm (063型: 0.8mm) 在1mm弯曲状态时进行测试。  (单位: mm)

多层陶瓷电容器

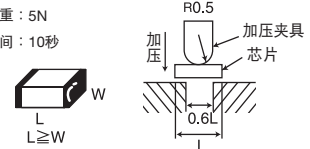
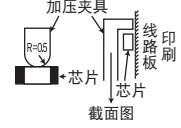
项 目	规 格 值				试验方法·摘要
	温度补偿用(1类)		高介电常数(2类)		
	普通用	高频用	普通用 注1	大容量用	
10.抗折强度	—	无破损等机械损伤	—	—	高频多层型： 加压荷重：5N 外加时间：10秒 
11.端子电极固着力	端子电极无松动及其他不良现象。			加压荷重：5N (042、063、096型 2N) 外加时间：30±5秒 	
12.可焊性	端子电极不少于95%的面积覆盖新涂层。				焊锡温度：230±5℃ 浸渍时间：4±1秒
13.焊接耐热性	外观：无异常 电容量变化： ±2.5% 或 ±0.25pF, 任一较大值以下。 Q值：初期规定值 绝缘阻抗：初期规定值 耐电压(端子间)：无异常	外观：无异常 电容量变化：±2.5%以内 Q值：初期规定值 绝缘阻抗：初期规定值 耐电压(端子间)：无异常	外观：无异常 电容量变化： BJ：±7.5%以内 注4 F：±20%以内 tan δ：初期规定值 绝缘阻抗：初期规定值 耐电压(端子间)：无异常	外观：无异常 电容量变化： BJ：±7.5%以内 注4 F：±20%以内 tan δ：初期规定值 绝缘阻抗：初期规定值 耐电压(端子间)：无异常	预处理：热处理(150℃1小时) / 2类适用 焊锡温度：270±5℃ 浸渍时间：3±0.5秒 预热条件：80~100℃ 2~5分钟或5~10分钟 150~200℃ 2~5分钟或5~10分钟 后期处理：测试后在标准状态下放置一段时间。 6~24小时(1类) 24±2小时(2类)
14.温度循环	外观：无异常 电容量变化： ±2.5% 或 ±0.25pF, 任一较大值以下。 Q值：初期规定值 绝缘阻抗：初期规定值 耐电压(端子间)：无异常	外观：无异常 电容量变化： ±0.25pF以内 Q值：初期规定值 绝缘阻抗：初期规定值 耐电压(端子间)：无异常	外观：无异常 电容量变化： BJ：±7.5%以内 注4 F：±20%以内 tan δ：初期规定值 绝缘阻抗：初期规定值 耐电压(端子间)：无异常	外观：无异常 电容量变化： BJ：±7.5%以内 注4 F：±20%以内 tan δ：初期规定值 绝缘阻抗：初期规定值 耐电压(端子间)：无异常	预处理：热处理(150℃1小时) / 2类适用 1回循环条件 / 步骤1：最低使用温度 -3℃ 30±3分钟 步骤2：常温 2~3分钟 步骤3：最高使用温度 -0℃ 30±3分钟 步骤4：常温 2~3分钟 试验次数：5回 试验后静放时间：6~24小时(1类) 24±2小时(2类)
15.耐湿性(稳态)	外观：无异常 电容量变化： ±5%或±0.5pF, 任一较大值以下。 Q值： C≥30pF： Q≥350 10≤C<30pF： Q≥275+2.5C C<10pF： Q≥200+10C C：标称电容量 绝缘阻抗：1000MΩ以上	外观：无异常 电容量变化： ±0.5pF以内 绝缘阻抗：1000MΩ以上	外观：无异常 电容量变化： BJ：±12.5%以内 F：±30%以内 tan δ： BJ：5.0%以下 注4 F：7.5%以下 绝缘阻抗：50MΩ μF 或1000MΩ, 任一较小值以上。 注5	外观：无异常 电容量变化： BJ：±12.5%以内 注4 tan δ： BJ：5.0%以下 注4 F：11.0%以下 绝缘阻抗：50MΩ μF 或1000MΩ, 任一较小值以上。 注5	多层型： 预处理：热处理(150℃ 1小时) / 2类适用 温度：40±2℃ 湿度：90~95%RH 试验时间：500 ⁺²⁴ ₋₀ 时间 后期处理：从试验容器中取出后，在标准状态下放置一段时间。 6~24小时(1类) 24±2小时(2类) 高频多层型： 温度：60±2℃ 湿度：90~95%RH 试验时间：500 ⁺²⁴ ₋₀ 时间 后期处理：从试验容器中取出后，在标准状态下放置一段时间。 6~24小时(1类)

多层陶瓷电容器

项 目	规 格 值				试验方法·摘要
	温度补偿用 (1类)		高介电常数 (2类)		
	普通用	高频用	普通用 注1	大容量用	
16.耐湿负载	外观：无异常 电容量变化： $\pm 7.5\%$ 或 $\pm 0.75\text{pF}$ ，任一较大值以下。 Q值： $C \geq 30\text{pF}$ ： $Q \geq 200$ $C < 30\text{pF}$ ： $Q \geq 100 + 10C/3$ C：标称电容量 绝缘阻抗：500MΩ以上	外观：无异常 电容量变化： $C \leq 2\text{pF}$ ： $\pm 0.4\text{pF}$ 以内 $C > 2\text{pF}$ ： $\pm 0.75\text{pF}$ 以内 C：标称电容量 绝缘阻抗：500MΩ以上	外观：无异常 电容量变化： BJ： $\pm 12.5\%$ 以内 F： $\pm 30\%$ 以内 注4 tan δ： BJ：5.0%以下 注4 F：7.5%以下 绝缘阻抗：25MΩ μF 或500MΩ，任一较小值以上。 注5	外观：无异常 电容量变化： BJ： $\pm 12.5\%$ 以内 F： $\pm 30\%$ 以内 注4 tan δ： BJ：5.0%以下 注4 F：11%以下 绝缘阻抗：25MΩ μF 或500MΩ，任一较小值以上。 注5	根据JIS C 5102规范9.9项。 多层型： 预处理：电压处理 (2类) 温度：40±2℃ 湿度：90~95%RH 试验时间：500 $^{+24}_0$ 时间 外加电压：额定电压 充放电电流：50mA以下 (1、2类) 后期处理：从试验容器中取出后，在标准状态下放置一段时间。 6~24小时 (1类) 24±2小时 (2类) 高频多层型： 温度：60±2℃ 湿度：90~95%RH 试验时间：500 $^{+24}_0$ 时间 外加电压：额定电压 充放电电流：50mA以下 后期处理：从试验容器中取出后，在标准状态下放置6~24小时
17.高温负载	外观：无异常 电容量变化： $\pm 3\%$ 或 $\pm 0.3\text{pF}$ ，任一较大值以下。 Q值： $C \geq 30\text{pF}$ ： $Q \geq 350$ $10 \leq C < 30$ $Q \geq 275 + 2.5C$ $C < 10\text{pF}$ ： $Q \geq 200 + 10C$ C：标称电容量 绝缘阻抗：1000MΩ以上	外观：无异常 电容量变化： $\pm 3\%$ 或 $\pm 0.3\text{pF}$ ，任一较大值以下。 绝缘阻抗：1000MΩ以上	外观：无异常 电容量变化： BJ： $\pm 12.5\%$ 以内 F： $\pm 30\%$ 以内 注4 tan δ： BJ：小于 4.0% F：小于 7.5% 绝缘阻抗：50MΩ μF 或1000MΩ，任一较小值以上。 注5	外观：无异常 电容量变化： BJ： $\pm 12.5\%$ 以内 F： $\pm 30\%$ 以内 注4 tan δ： BJ：小于 5.0% F：小于 11% 注4 绝缘阻抗：50MΩ μF 或1000MΩ，任一较小值以上。 注5	根据JIS C 5102规范9.10项。 多层型： 预处理：电压处理 (2类) 温度：125℃±3℃ (1类、2类；B、BJ (X7R)) 85℃±2℃ (2类；BJ、F) 试验时间：1000 $^{+48}_0$ 时间 外加电压：额定电压×2 注6 后期处理：从试验容器中取出后，在标准状态下放置一段时间。 6~24小时 (1类) 24±2小时 (2类) 高频多层型 温度：125±3℃ (1类) 试验时间：1000 $^{+48}_0$ 时间 外加电压：额定电压×2 后期处理：从试验容器中取出后，在标准状态下放置6~24小时。

注1 063, 105型参照“大容量”。

注2 热处理 (多层型)：测试之前，应在 150 $^{+0}_{-10}$ ℃下进行1小时的热处理，并在标准状况下放置24±2小时。

注3 电压处理 (多层型)：测试之前，应在测试规定温度和电压下进行1小时的电压处理并在标准状况下放置24±2小时。

注4、5 本数值为代表值。详情请参照各自规格。

注6 有些部件适用额定电压×1.5。详情请参照个别规格书。

此处所述“标准状态”为：







温度5~35℃、相对湿度45~85%、气压86~106kPa

对测试结果存有疑问时，则在以下条件下进行测试：温度20±2℃、相对湿度60~70%、气压86~106kPa。如无特别指定，所有测试全部在“标准状态”下进行。

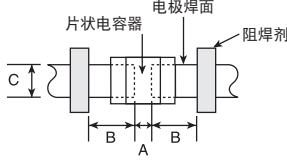
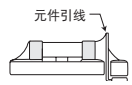
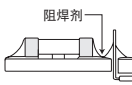
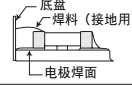
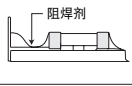
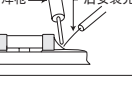
多层陶瓷电容器

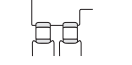
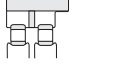
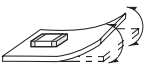
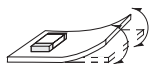
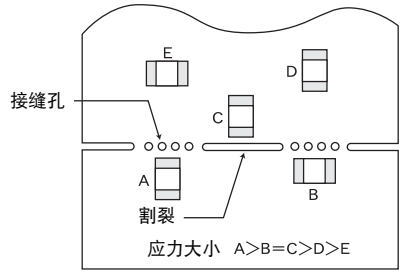
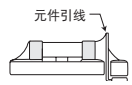
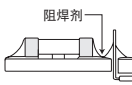
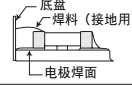
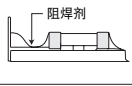
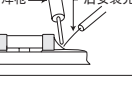
工 序 名	注 意 事 项	管 理 要 点																																																																																																																																		
1.电路设计	<p>◆使用环境、电气规定值和产品性能的确认</p> <p>1.如果医疗器械、航天器和原子核反应堆等设备出现故障，会对人的生命乃至整个社会造成严重的危害。 因此用于这些设备的电容器与一般用途不同，在设计上必须具有很高的安全性和可靠性。</p> <p>◆工作电压（额定电压的确认）</p> <p>1.电容器的工作电压必须低于其额定电压值。 如果在一个直流电压上加载一个交流电压，那么两个峰值电压之和应小于所选择的电容器的额定值。 对于同时使用交流电压和脉冲电压的电路，它们的峰值电压之和也应低于电容器的额定电压。</p> <p>2.即使外加电压低于额定电压值，如果电路中使用的高频交流电压或脉冲电压升高的时间过快，那么电容器的性能会因此被削弱。</p>																																																																																																																																			
2.印刷电路板设计	<p>◆安装定位设计 (焊盘图案设计)</p> <p>1.当电容器被安装在印刷电路板上后，所使用的焊料量（焊脚尺寸）会直接影响电容器的性能。因此在设计焊盘图案时必须考虑到以下几点：</p> <p>(1)所用焊料量的大小会影响晶片抗机械应力的能力，从而可能导致电容器破损或开裂。因此在设计印刷电路板时，为了有合适的焊料量，必须正确设定形状和尺寸。</p> <p>(2)如果两个以上的元件被焊接在同一印刷电路板上时，焊盘的设计应可以使每个元件的焊接点被阻焊剂隔离开。</p>	<p>1.为防止焊料量过多，按如下推荐示例所示设置焊盘尺寸，并避免不合理的印刷电路板设计。</p> <p>(1)推荐使用的印刷电路板上焊盘的尺寸 印刷电路板电极焊面相关</p>  <p>波峰焊推荐焊盘尺寸 (单位:mm)</p> <table border="1" data-bbox="836 1039 1201 1207"> <thead> <tr> <th>类型</th> <th>107</th> <th>212</th> <th>316</th> <th>325</th> </tr> </thead> <tbody> <tr> <td rowspan="2">尺寸</td> <td>L</td> <td>1.6</td> <td>2.0</td> <td>3.2</td> <td>3.2</td> </tr> <tr> <td>W</td> <td>0.8</td> <td>1.25</td> <td>1.6</td> <td>2.5</td> </tr> <tr> <td>A</td> <td>0.8~1.0</td> <td>1.0~1.4</td> <td>1.8~2.5</td> <td>1.8~2.5</td> </tr> <tr> <td>B</td> <td>0.5~0.8</td> <td>0.8~1.5</td> <td>0.8~1.7</td> <td>0.8~1.7</td> </tr> <tr> <td>C</td> <td>0.6~0.8</td> <td>0.9~1.2</td> <td>1.2~1.6</td> <td>1.8~2.5</td> </tr> </tbody> </table> <p>回流焊推荐焊盘尺寸 (单位:mm)</p> <table border="1" data-bbox="836 1270 1421 1438"> <thead> <tr> <th>类型</th> <th>042</th> <th>063</th> <th>105</th> <th>107</th> <th>212</th> <th>316</th> <th>325</th> <th>432</th> </tr> </thead> <tbody> <tr> <td rowspan="2">尺寸</td> <td>L</td> <td>0.4</td> <td>0.6</td> <td>1.0</td> <td>1.6</td> <td>2.0</td> <td>3.2</td> <td>3.2</td> <td>4.5</td> </tr> <tr> <td>W</td> <td>0.2</td> <td>0.3</td> <td>0.5</td> <td>0.8</td> <td>1.25</td> <td>1.6</td> <td>2.5</td> <td>3.2</td> </tr> <tr> <td>A</td> <td>0.15~0.25</td> <td>0.20~0.30</td> <td>0.45~0.55</td> <td>0.8~1.0</td> <td>0.8~1.2</td> <td>1.8~2.5</td> <td>1.8~2.5</td> <td>2.5~3.5</td> </tr> <tr> <td>B</td> <td>0.10~0.20</td> <td>0.20~0.30</td> <td>0.40~0.50</td> <td>0.6~0.8</td> <td>0.8~1.2</td> <td>1.0~1.5</td> <td>1.0~1.5</td> <td>1.5~1.8</td> </tr> <tr> <td>C</td> <td>0.15~0.30</td> <td>0.25~0.40</td> <td>0.45~0.55</td> <td>0.6~0.8</td> <td>0.9~1.6</td> <td>1.2~2.0</td> <td>1.8~3.2</td> <td>2.3~3.5</td> </tr> </tbody> </table> <p>过量的焊料会影响晶片耐机械应力的能力。因此在设计印刷电路板时，需注意这些事项。</p> <p>推荐用于多连型多层电容器的焊盘尺寸</p> <table border="1" data-bbox="836 1617 1006 1816"> <thead> <tr> <th>类型</th> <th>212 (4连型)</th> </tr> </thead> <tbody> <tr> <td rowspan="2">尺寸</td> <td>L</td> <td>2.0</td> </tr> <tr> <td>W</td> <td>1.25</td> </tr> <tr> <td>a</td> <td>0.5~0.6</td> </tr> <tr> <td>b</td> <td>0.5~0.6</td> </tr> <tr> <td>c</td> <td>0.2~0.3</td> </tr> <tr> <td>d</td> <td>0.5</td> </tr> </tbody> </table> <table border="1" data-bbox="836 1827 1226 2026"> <thead> <tr> <th>类型</th> <th>212 (2连型)</th> <th>110 (2连型)</th> <th>096 (2连型)</th> </tr> </thead> <tbody> <tr> <td rowspan="2">尺寸</td> <td>L</td> <td>2.0</td> <td>1.37</td> <td>0.9</td> </tr> <tr> <td>W</td> <td>1.25</td> <td>1.0</td> <td>0.6</td> </tr> <tr> <td>a</td> <td>0.5~0.6</td> <td>0.35~0.45</td> <td>0.25~0.35</td> </tr> <tr> <td>b</td> <td>0.5~0.6</td> <td>0.55~0.65</td> <td>0.15~0.25</td> </tr> <tr> <td>c</td> <td>0.5~0.6</td> <td>0.3~0.4</td> <td>0.15~0.25</td> </tr> <tr> <td>d</td> <td>1.0</td> <td>0.64</td> <td>0.45</td> </tr> </tbody> </table> 	类型	107	212	316	325	尺寸	L	1.6	2.0	3.2	3.2	W	0.8	1.25	1.6	2.5	A	0.8~1.0	1.0~1.4	1.8~2.5	1.8~2.5	B	0.5~0.8	0.8~1.5	0.8~1.7	0.8~1.7	C	0.6~0.8	0.9~1.2	1.2~1.6	1.8~2.5	类型	042	063	105	107	212	316	325	432	尺寸	L	0.4	0.6	1.0	1.6	2.0	3.2	3.2	4.5	W	0.2	0.3	0.5	0.8	1.25	1.6	2.5	3.2	A	0.15~0.25	0.20~0.30	0.45~0.55	0.8~1.0	0.8~1.2	1.8~2.5	1.8~2.5	2.5~3.5	B	0.10~0.20	0.20~0.30	0.40~0.50	0.6~0.8	0.8~1.2	1.0~1.5	1.0~1.5	1.5~1.8	C	0.15~0.30	0.25~0.40	0.45~0.55	0.6~0.8	0.9~1.6	1.2~2.0	1.8~3.2	2.3~3.5	类型	212 (4连型)	尺寸	L	2.0	W	1.25	a	0.5~0.6	b	0.5~0.6	c	0.2~0.3	d	0.5	类型	212 (2连型)	110 (2连型)	096 (2连型)	尺寸	L	2.0	1.37	0.9	W	1.25	1.0	0.6	a	0.5~0.6	0.35~0.45	0.25~0.35	b	0.5~0.6	0.55~0.65	0.15~0.25	c	0.5~0.6	0.3~0.4	0.15~0.25	d	1.0	0.64	0.45
类型	107	212	316	325																																																																																																																																
尺寸	L	1.6	2.0	3.2	3.2																																																																																																																															
	W	0.8	1.25	1.6	2.5																																																																																																																															
A	0.8~1.0	1.0~1.4	1.8~2.5	1.8~2.5																																																																																																																																
B	0.5~0.8	0.8~1.5	0.8~1.7	0.8~1.7																																																																																																																																
C	0.6~0.8	0.9~1.2	1.2~1.6	1.8~2.5																																																																																																																																
类型	042	063	105	107	212	316	325	432																																																																																																																												
尺寸	L	0.4	0.6	1.0	1.6	2.0	3.2	3.2	4.5																																																																																																																											
	W	0.2	0.3	0.5	0.8	1.25	1.6	2.5	3.2																																																																																																																											
A	0.15~0.25	0.20~0.30	0.45~0.55	0.8~1.0	0.8~1.2	1.8~2.5	1.8~2.5	2.5~3.5																																																																																																																												
B	0.10~0.20	0.20~0.30	0.40~0.50	0.6~0.8	0.8~1.2	1.0~1.5	1.0~1.5	1.5~1.8																																																																																																																												
C	0.15~0.30	0.25~0.40	0.45~0.55	0.6~0.8	0.9~1.6	1.2~2.0	1.8~3.2	2.3~3.5																																																																																																																												
类型	212 (4连型)																																																																																																																																			
尺寸	L	2.0																																																																																																																																		
	W	1.25																																																																																																																																		
a	0.5~0.6																																																																																																																																			
b	0.5~0.6																																																																																																																																			
c	0.2~0.3																																																																																																																																			
d	0.5																																																																																																																																			
类型	212 (2连型)	110 (2连型)	096 (2连型)																																																																																																																																	
尺寸	L	2.0	1.37	0.9																																																																																																																																
	W	1.25	1.0	0.6																																																																																																																																
a	0.5~0.6	0.35~0.45	0.25~0.35																																																																																																																																	
b	0.5~0.6	0.55~0.65	0.15~0.25																																																																																																																																	
c	0.5~0.6	0.3~0.4	0.15~0.25																																																																																																																																	
d	1.0	0.64	0.45																																																																																																																																	

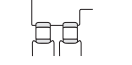
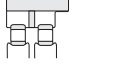
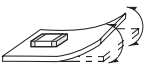
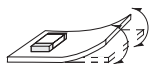
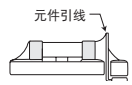
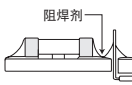
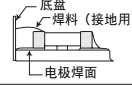
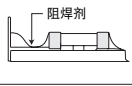
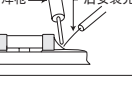
多层陶瓷电容器

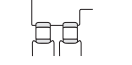
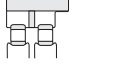
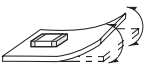
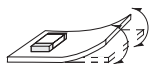
工 序 名	注 意 事 项	管 理 要 点																																																				
2.印刷电路板设计	<p>◆安装定位设计 (分割印刷电路板上电容器配置)</p> <p>1.安装电容器至印刷电路板后，在连续生产工序中(印刷电路板分割、线路板检测、其他部件安装、底盘组装、波峰焊与回流焊等等)或在操作过程中会产生印刷电路板弯曲、晶片破裂等情况，因此请将电容器配置在印刷电路板弯曲时所受应力最小处。</p>	<p>LWDC用推荐焊垫尺寸(单位mm)</p>  <table border="1" data-bbox="841 451 1209 630"> <thead> <tr> <th>型号</th> <th>105</th> <th>107</th> <th>212</th> <th>316</th> </tr> </thead> <tbody> <tr> <td rowspan="2">尺寸</td> <td>W</td> <td>1.0</td> <td>1.6</td> <td>2.0</td> <td>3.2</td> </tr> <tr> <td>L</td> <td>0.52</td> <td>0.8</td> <td>1.25</td> <td>1.6</td> </tr> <tr> <td>A</td> <td>0.18~0.22</td> <td>0.25~0.3</td> <td>0.5~0.7</td> <td>0.8~1.0</td> </tr> <tr> <td>B</td> <td>0.2~0.25</td> <td>0.3~0.4</td> <td>0.4~0.5</td> <td>0.4~0.5</td> </tr> <tr> <td>C</td> <td>0.9~1.1</td> <td>1.5~1.7</td> <td>1.9~2.1</td> <td>3.0~3.4</td> </tr> </tbody> </table> <p>(单位mm)</p> <p>(2)防止及推荐事例</p> <table border="1" data-bbox="836 724 1412 1144"> <thead> <tr> <th>项目</th> <th>防止事例</th> <th>推荐事例</th> </tr> </thead> <tbody> <tr> <td>和引线元件混合安装</td> <td></td> <td></td> </tr> <tr> <td>靠近底盘的元件安装</td> <td></td> <td></td> </tr> <tr> <td>引线元件后安装</td> <td></td> <td></td> </tr> <tr> <td>水平安装元件</td> <td></td> <td></td> </tr> </tbody> </table> <p>1-1.要对印刷电路板的弯曲处不施加过度的机械应力，推荐如下所示配置电容器。</p> <table border="1" data-bbox="836 1249 1412 1396"> <thead> <tr> <th></th> <th>防止事例</th> <th>推荐事例</th> </tr> </thead> <tbody> <tr> <td>线路板弯曲</td> <td></td> <td></td> </tr> </tbody> </table> <p>1-2.将电容器安装在切割线路板上时，机械应力的大小由电容器的布局而定。请参考下图：</p>  <p>1-3.分割印刷电路板时，电容器所受机械应力的大小为：推板<割裂<V形凹槽<接缝孔。因此，在配置电容器时必须同时考虑到印刷电路板的分割方法。</p>	型号	105	107	212	316	尺寸	W	1.0	1.6	2.0	3.2	L	0.52	0.8	1.25	1.6	A	0.18~0.22	0.25~0.3	0.5~0.7	0.8~1.0	B	0.2~0.25	0.3~0.4	0.4~0.5	0.4~0.5	C	0.9~1.1	1.5~1.7	1.9~2.1	3.0~3.4	项目	防止事例	推荐事例	和引线元件混合安装			靠近底盘的元件安装			引线元件后安装			水平安装元件				防止事例	推荐事例	线路板弯曲		
型号	105	107	212	316																																																		
尺寸	W	1.0	1.6	2.0	3.2																																																	
	L	0.52	0.8	1.25	1.6																																																	
A	0.18~0.22	0.25~0.3	0.5~0.7	0.8~1.0																																																		
B	0.2~0.25	0.3~0.4	0.4~0.5	0.4~0.5																																																		
C	0.9~1.1	1.5~1.7	1.9~2.1	3.0~3.4																																																		
项目	防止事例	推荐事例																																																				
和引线元件混合安装																																																						
靠近底盘的元件安装																																																						
引线元件后安装																																																						
水平安装元件																																																						
	防止事例	推荐事例																																																				
线路板弯曲																																																						

多层陶瓷电容器

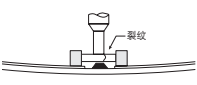
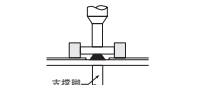
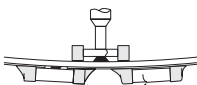
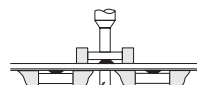
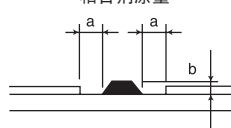
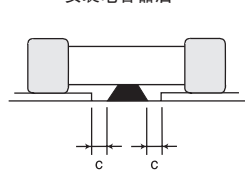
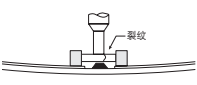
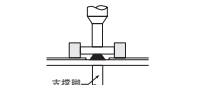
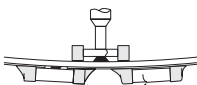
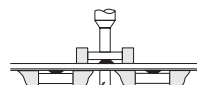
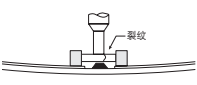
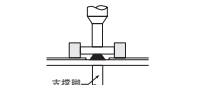
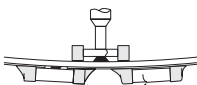
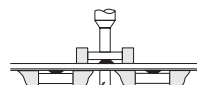
工 序 名	注 意 事 项	管 理 要 点																	
3.自动装配	<p>◆调整贴片机</p> <ol style="list-style-type: none"> 1.在将电容器安装在印刷线路板上时，不能让电容器承受过量的冲击力。 2.应定期对贴片机进行维修和点检。 <p>◆粘合剂的选用</p> <ol style="list-style-type: none"> 1.在焊接安装电容器之前，用粘合剂将电容器暂时固定在印刷线路板上时，如果没有正确设置焊盘尺寸、粘合剂的类型和涂布量、硬化的温度和时间等，将可能导致电容器的特性劣化，因此，在操作时请先确认或咨询。 	<ol style="list-style-type: none"> 1.吸拾管下限较低的场合在自动安装时，过度压力将作用于电感器从而导致其损坏。请参照下述要点： <ol style="list-style-type: none"> (1)请调整吸拾管的下限至弯曲校正后印刷线路板的表面水平位置。 (2)自动安装时，请设定喷嘴压力为1~3N。 (3)为了减少吸拾管对印刷线路板的压力作用从而导致的线路板弯曲量，在线路板下方应使用支撑脚或挡块。请参照以下代表例： <table border="1" data-bbox="841 430 1412 688"> <thead> <tr> <th></th> <th>防止事例</th> <th>推荐事例</th> </tr> </thead> <tbody> <tr> <td>单面安装</td> <td></td> <td></td> </tr> <tr> <td>双面安装</td> <td></td> <td></td> </tr> </tbody> </table> <ol style="list-style-type: none"> 2.如果定位爪磨损，在定位时，会对电容器的局部造成机械冲击，导致电容器缺口或开裂。为了避免上述情况的发生，请确定停止位置定位爪之间的宽度，并定期执行定位爪的保养、点检及更新。 <ol style="list-style-type: none"> 1.一些粘合剂会降低电容器的绝缘阻抗。粘合剂和电容器收缩率的不同会在电容器上产生应力并导致开裂。甚至粘合剂涂布的过多或过少会影响元件的安装，导致故障发生。因此在使用时应注意以下事项： <ol style="list-style-type: none"> (1)粘合剂的选定： <ol style="list-style-type: none"> a.粘合剂应具有足够强度保证贴片过程中部品不致脱落。 b.高温下粘合剂应具有足够强度。 c.粘合剂应具有良好涂层及厚度的保持性。 d.粘合剂应具有足够长的贮存期。 e.粘合剂应具有短时间内快速硬化的特性。 f.粘合剂应无腐蚀性。 g.粘合剂应具有优良的绝缘特性。 h.粘合剂应无害且不会发出对人体有害气体。 (2)粘合剂推荐使用量如下所示。 <p>在印刷线路板上焊接电容器时，注意不要因粘合剂的用量不当而导致电容器脱落或过量的焊料溢出等焊接不良情况发生。</p> <p>[推荐条件]</p> <table border="1" data-bbox="885 1297 1409 1417"> <thead> <tr> <th>标 记</th> <th>以212/316为例</th> </tr> </thead> <tbody> <tr> <td>a</td> <td>0.3mm min</td> </tr> <tr> <td>b</td> <td>100~120 μm</td> </tr> <tr> <td>c</td> <td>不要使粘合剂接触到底盘</td> </tr> </tbody> </table> <div style="display: flex; justify-content: space-around; margin-top: 20px;"> <div data-bbox="876 1470 1104 1617"> <p>粘合剂涂量</p>  </div> <div data-bbox="1161 1470 1404 1659"> <p>安装电容器后</p>  </div> </div>		防止事例	推荐事例	单面安装			双面安装			标 记	以212/316为例	a	0.3mm min	b	100~120 μm	c	不要使粘合剂接触到底盘
	防止事例	推荐事例																	
单面安装																			
双面安装																			
标 记	以212/316为例																		
a	0.3mm min																		
b	100~120 μm																		
c	不要使粘合剂接触到底盘																		

多层陶瓷电容器

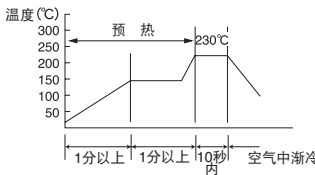
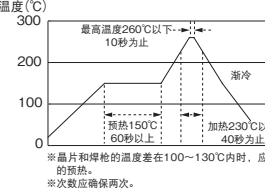
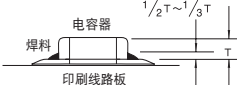
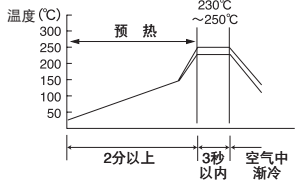
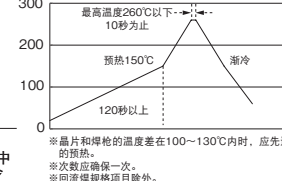
工 序 名	注 意 事 项	管 理 要 点
4.焊接	<p>◆助焊剂的选用</p> <p>1.由于助焊剂可能对电容器性能有显著影响,因此在使用之前必须确认符合以下条件:</p> <p>(1)所用助焊剂的卤化物含量不应多于0.1wt% (Cl换算)。不能使用高酸性的助焊剂。</p> <p>(2)在线路板上焊接电容器时,助焊剂应使用必要的最小量。</p> <p>(3)使用水溶性助焊剂时,要先将底板清洗干净。</p> <p>◆焊接</p> <p>1.请按照以下推荐的条件设定温度、时间、焊料量等。</p> <p>使用Sn-Zn系焊接材料将影响多层陶瓷片状电容的可靠性。若要使用Sn-Zn系焊接材料,请事先与本公司联系。</p>	<p>1-1.如果活化助焊剂中的卤化物过多或使用了高酸性的助焊剂,那么焊接后过多的残留物会腐蚀电容器端子电极或使电容器表面的绝缘阻抗降低。</p> <p>1-2.在波峰焊接过程中使用助焊剂是为了增强电容器的可焊性,但如使用过多的助焊剂,助焊剂大量的雾气会射到电容器上,从而使电容器可焊性受到破坏性的影响。应尽可能减少助焊剂的用量,推荐使用发泡方式。</p> <p>1-3.由于水溶性助焊剂的残留物有易溶于湿气的物质,因此高温条件下电容器表面上的残留物会导致电容器绝缘下降并影响电容器的可靠性。当选用了水溶性助焊剂时,要特别注意清洗方法和所使用的机器的能力。</p> <p>1-1.焊接时的预处理: 为使电容器和焊料温度差小于100~130℃,在焊接前应进行充分地预热。同时,焊接后清洗等急速冷却温度与电感器温度差不能超过100℃。电感器在急冷、急热或局部加热的情况下易于破损,焊接时请充分注意由于热冲击等所导致的产品故障。</p> <p>【焊接推荐条件】 [回流焊接] 温度曲线</p>  <p>【无铅焊接推荐条件】</p>  <p>※晶片和焊枪的温度差在100~130℃内时,应先进行充分的预热。 ※次数应确保两次。</p> <p>注意事项</p> <p>①理想的焊料量应为电容器厚度的1/2~1/3。如下图所示:</p>  <p>②请尽可能缩短焊接熔融时间。</p> <p>【波峰焊接】 [回流焊接] 温度曲线</p>  <p>【无铅焊接推荐条件】</p>  <p>※晶片和焊枪的温度差在100~130℃内时,应先进行充分的预热。 ※次数应确保一次。 ※回流焊接项目除外。</p> <p>注意事项</p> <p>①确保电容器已经预热充分。</p> <p>②电容器和熔化的焊料之间的温度之差不能大于100~130℃。</p> <p>③焊接后的冷却方法应尽可能是自然冷却。</p> <p>④指定仅可用回流焊接的电容器不能用波峰焊接。</p>

Te

多层陶瓷电容器

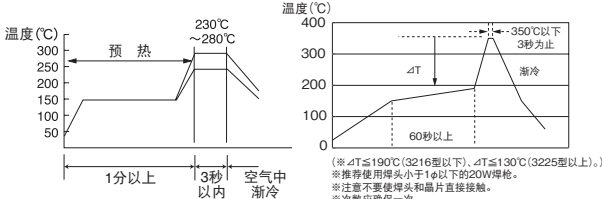
工序名	注意事项	管理要点
4.焊接		<p>【共晶焊接推荐条件】</p> <p>【无铅焊接推荐条件】</p> <p>[手工焊接]</p> <p>温度曲线</p>  <p>注意事项</p> <p>①推荐使用的焊枪的焊头直径最大为1mm。</p> <p>②注意焊头不能直接接触到电容器上。</p>
5.清洗	<p>◆印刷电路板清洗</p> <p>1. 在安装完所有的电容器后，在清洗印刷电路板时，应根据所使用的助焊剂和清洗的目的（如为了除掉焊接时残留的助焊剂还是生产过程中的其他材料）来选用适当的清洗溶剂。</p> <p>2. 应对清洗条件进行核对和确认清洗过程不影响电容器的特性。</p>	<p>1. 如果使用不恰当的溶剂，会使其他物质如助焊剂残留物粘到电容器或破坏电容器的外部涂层，从而导致电容器的电性能下降(特别是绝缘阻抗)。</p> <p>2. 清洗条件不恰当（清洗不足，过度清洗）可能导致电容器性能受损。</p> <p>(1) 过度清洗</p> <p>a. 超声波清洗条件下，过大功率输出可能导致印刷电路板过度震动从而使电容器本体及焊接部分断裂，或降低端子电极强度。因此请慎重考虑以下条件：</p> <p>超声波输出：20W / ℓ 以下 超声波频率：40kHz以下 超声波清洗时间：5分钟以下</p>
6.后期工序	<p>◆树脂涂装及成型</p> <p>1. 一些类型的树脂在硬化过程及自然放置状态下所产生的树脂分解废气及化学反应气体会停留在树脂内部从而导致电容器性能的劣化。</p> <p>2. 当树脂硬化温度超过电容器使用温度条件时，由于受到过热膨胀收缩应力作用从而导致电容器破损。</p>	
7.处理	<p>◆印刷电路板分割</p> <p>1. 在安装完电容器和其它元件后，分割印刷电路板时，注意不在板上施加任何弯曲及扭转力。</p> <p>2. 线路板的分割不能用手分割，应使用专用夹具。</p> <p>◆机械冲击</p> <p>1. 注意不能让电容器承受过量的机械冲击</p> <p>(1) 如果电容器因掉落等原因受到过度的机械冲击，则不能再进行使用。</p> <p>(2) 当处理已安装有电容器的印刷电路板时，请避免使电感器触碰其他印刷电路板等部品。</p>	

多层陶瓷电容器

工 序 名	注 意 事 项	管 理 要 点
8. 储存・保管	<p>◆ 储存・保管</p> <p>1. 为防止包装材料以及外部电极可焊性受损，请充分管理保存场所的温度和湿度条件，尤其对于湿度条件，请尽可能降低环境中的湿度条件。</p> <ul style="list-style-type: none"> ・ 请将本产品贮存于温度30℃以下且湿度为70%RH以下的环境中（推荐环境温度为40℃以下）。注意，即使处于良好的保存环境下，焊接特性也会随时间劣化。因此，请于本公司发货后6个月以内使用。 ・ 请在空气中无氯和硫磺之处保管。 <p>2. 高介电常数的电容器（1类、3类）的容量将随着时间的推移而下降，因此在设计电路时要考虑到这一点。如果电容器的容量值减少了，在150℃的条件下对电容器进行1小时预热，那么电容器的容量值会恢复到初期规定值。</p>	<p>1. 如果将电容器存放在高温和高湿的环境下，电容器的端电极就会被氧化，从而导致其可焊性下降；另外，在这种储存条件下，电容器的编带/包装材料会受到破坏。出于这个原因，电容器应在自发货之日算起6个月内使用。如果超出了这个期限，在使用电容器之前要对其可焊性进行检验。</p>