

Surface Mount Aluminum Electrolytic Capacitors NACVF Series

FEATURES

- CYLINDRICAL V-CHIP CONSTRUCTION FOR SURFACE MOUNT
- HIGH VOLTAGE (160VDC AND 450VDC)
- 10mm x 14mm ~ 18mm x 22mm CASE SIZES
- LONG LIFE (5000 HOURS AT +105°C)
- DESIGNED FOR REFLOW SOLDERING

**RoHS
Compliant**
includes all homogeneous materials

*See Part Number System for Details



CHARACTERISTICS

Rated Voltage Range		160 ~ 450Vdc					
Rated Capacitance Range		2.2 ~ 100μF					
Operating Temperature Range		-40°C ~ +105°C					
Capacitance Tolerance		±20% (M)					
Max. Leakage Current After 2 Minutes		0.06CV + 10μA					
Max. Tan δ at 120Hz & 20°C		160Vdc	200Vdc	250Vdc	350Vdc	400Vdc	450Vdc
		0.15			0.20	0.24	
Low Temperature Stability (Impedance Ratio @ 120Hz)	Z -25°C/+20°C	2	2	3	5	6	6
	Load Life @ 105°C & Rated Voltage 10x14mm 3,000 hours 10x18mm 4,000 hours 12.5 ~ 18mm Dia 5,000 hours	Capacitance Change					
	Within ±20% of initial measured value						
		Tan δ					
		Less than 200% of specified value					
		Leakage Current					
		Less than the specified maximum value					
Resistance to Soldering Heat Within the Recommended Reflow Conditions	Capacitance Change	Within ±10% of initial measured value					
	Tan δ	Less than the specified maximum value					
	Leakage Current	Less than the specified maximum value					

STANDARD PRODUCT AND CASE SIZE TABLE DφxL (mm)

Cap (μF)	Code	Working Voltage (Vdc)					
		160	200	250	350	400	450
2.2	2R2	-	-	-	-	-	10 x 14
3.3	3R3	-	-	-	10 x 14	10 x 14	10 x 18
4.7	4R7	-	-	-	10 x 18	10 x 18	12.5 x 17
10	100	10 x 14	10 x 18	10 x 18	16 x 17	16 x 17	18 x 17
22	220	-	12.5 x 17	16 x 17	18 x 17	16 x 22	18 x 22
33	330	12.5 x 17	16 x 17	18 x 17	16 x 22	18 x 22	-
47	470	16 x 17	18 x 17	16 x 22	18 x 22	-	-
68	680	18 x 17	16 x 22	18 x 22	-	-	-
		18 x 22					
100	101	18 x 22	18 x 22	-	-	-	-

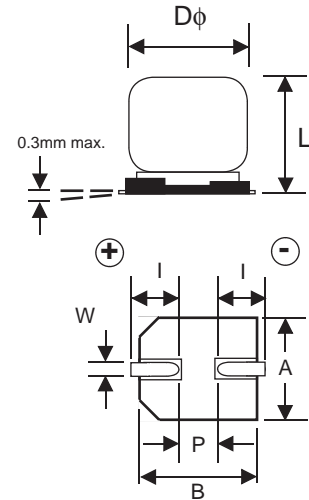

DIMENSIONS (mm)

Case Size	Dφ ±0.5	L max.	A ±0.2	B ±0.2	I ±0.2	W	P ±0.2
10 x 14T2	10.0	14.0	10.3	10.3	3.5	0.7 ~ 1.4	4.6
10 x 18T2	10.0	18.5	10.3	10.3	3.5	1.1 ~ 1.4	4.6
12.5 x 17T2	12.5	17.5	13.5	13.5	4.7	0.6 ~ 1.2	4.4
16 x 17T2	16.0	17.5	17.0	17.0	5.5	0.9 ~ 1.5	6.7
18 x 17T2	18.0	17.5	19.0	19.0	6.5	0.9 ~ 1.5	6.7
18 x 22T2	18.0	22.5	19.0	19.0	6.5	0.9 ~ 1.5	6.7

RECOMMENDED LAND PATTERN DIMENSIONS (mm)

Case Size	a	b	c
10 φ	4.0	4.5	2.0
12.5 φ	4.0	5.7	2.0
16 φ	6.0	6.5	2.5
18 φ	6.0	7.5	2.5

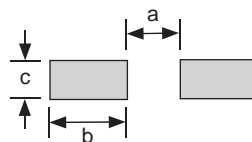

PRECAUTIONS

Please review the notes on correct use, safety and precautions found on pages T10 & T11 of NIC's Electrolytic Capacitor catalog.
Also found at www.niccomp.com/precautions
If in doubt or uncertainty, please review your specific application - process details with NIC's technical support personnel: tpmg@niccomp.com



Surface Mount Aluminum Electrolytic Capacitors NACVF Series

STANDARD VALUES, CASE SIZES AND SPECIFICATIONS

NIC Part Number	Cap. (μF)	W.V. (Vdc)	Dissipation Factor (Tan δ)	Max. Ripple Current (mA) +105°C/100KHz	Max. ESR (Ω) +20°C/120Hz	Load Life Hours @ +105°C
NACVF100M160V10X14TR13T2F	10	160	0.15	70	24.9	3,000
NACVF330M160V12.5X17TR13T2F	33		0.15	470	7.55	5,000
NACVF470M160V16X17TR13T2F	47		0.15	600	5.30	5,000
NACVF680M160V18X17TR13T2F	68		0.15	750	3.66	5,000
NACVF680M160V18X22TR13T2F						
NACVF101M160V18X22TR13T2F	100		0.15	1060	2.49	5,000
NACVF100M200V10X18TR13T2F	10	200	0.15	80	24.9	4,000
NACVF220M200V12.5X17TR13T2F	22		0.15	470	11.3	5,000
NACVF330M200V16X17TR13T2F	33		0.15	600	7.55	5,000
NACVF470M200V18X17TR13T2F	47		0.15	600	5.30	5,000
NACVF680M200V16X22TR13T2F	68		0.15	750	3.66	5,000
NACVF101M200V18X22TR13T2F	100		0.15	1060	2.49	5,000
NACVF100M250V10X18TR13T2F	10	250	0.15	88	24.9	4,000
NACVF220M250V16X17TR13T2F	22		0.15	560	11.3	5,000
NACVF330M250V18X17TR13T2F	33		0.15	560	7.55	5,000
NACVF470M250V16X22TR13T2F	47		0.15	710	5.30	5,000
NACVF680M250V18X22TR13T2F	68		0.15	990	3.66	5,000
NACVF3R3M350V10X14TR13T2F	3.3		350	0.20	38	101
NACVF4R7M350V10X18TR13T2F	4.7	0.20		50	70.7	3,000
NACVF100M350V16X17TR13T2F	10	0.20		270	33.2	5,000
NACVF220M350V18X17TR13T2F	22	0.20		350	15.1	5,000
NACVF330M350V16X22TR13T2F	33	0.20		480	10.1	5,000
NACVF470M350V18X22TR13T2F	47	0.20		670	7.07	5,000
NACVF3R3M400V10X14TR13T2F	3.3	400	0.24	40	121	3,000
NACVF4R7M400V10X18TR13T2F	4.7		0.24	50	84.8	4,000
NACVF100M400V16X17TR13T2F	10		0.24	250	39.9	5,000
NACVF220M400V16X22TR13T2F	22		0.24	410	18.1	5,000
NACVF330M400V18X22TR13T2F	33		0.24	600	12.1	5,000
NACVF2R2M450V10X14TR13T2F	2.2		450	0.24	29	181
NACVF3R3M450V10X18TR13T2F	3.3	0.24		41	121	4,000
NACVF4R7M450V12.5X17TR13T2F	4.7	0.24		49	84.8	5,000
NACVF100M450V18X17TR13T2F	10	0.24		310	39.9	5,000
NACVF220M450V18X22TR13T2F	22	0.24		560	18.1	5,000

RIPPLE CURRENT FREQUENCY CORRECTION FACTORS

Voltage (Vdc)	Frequency (Hz)			
	120	1K	10K ~ 30K	31K ~ 100K
160V ~ 250V	0.55	0.85	0.90	1.00
350V ~ 450V	0.50	0.80	0.90	1.00

Review & Compare Reflow Soldering Heat Limits
V-chip SMT Aluminum Electrolytic Capacitors
www.niccomp.com/RSL

PART NUMBER SYSTEM

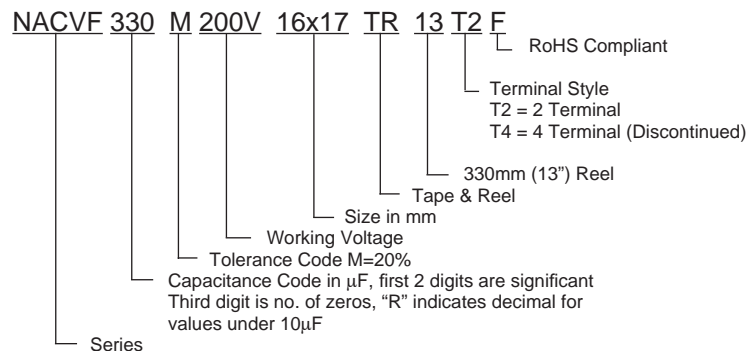

Surface Mount Aluminum Electrolytic Capacitors NACVF Series

CARRIER TAPE

Case Size	A ±0.5	B ±0.2	C ±0.3	D ±0.1	P ±0.1	T ±0.2
10 x 14	10.7	10.7	32.0	14.2	20.0	14.5
10 x 18	10.7	10.7	32.0	14.2	20.0	18.5
12.5 x 17T2	14.0	14.0	32.0	14.2	24.0	17.5
16 x 17T2	17.5	17.5	44.0	20.2	28.0	17.5
18 x 17T2	19.5	19.5	44.0	20.2	32.0	17.5
18 x 22T2	19.5	19.5	44.0	20.2	32.0	22.5

TR13 330mm (13") REEL TR15 380mm (15") REEL

Case Size	W ±1.0	Quantity Per Reel	
		13" Reel	15" Reel
10 x 14	34.0	250 pcs	300 pcs
10 x 18	34.0	200 pcs	300 pcs
12.5 x 17T2	34.0	150 pcs	-
16 x 17T2	46.0	125 pcs	-
18 x 17T2	46.0	125 pcs	-
18 x 22T2	46.0	75 pcs	-

TAPING SPECIFICATIONS (mm)

- Both Leader and Trailer tape: Minimum 40mm (1.57") empty carrier tape pockets.
- Leader tape: Approximately 20cm of cover tape at leader.
- Connection: Maximum 3 connections (slices) per reel.

CARRIER

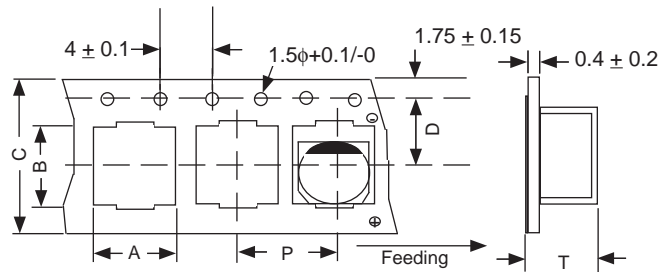

REEL

