

Features

- RoHS compliant*
- Multiple SCSI termination resistors
- Stable thin-film-on-silicon technology
- Ultra-miniature packages to JEDEC standards



Models 2QSP-XX3 and 2NBS-XX3 are obsolete and not recommended for new designs.

Applications

- Single-ended SCSI termination
- SCSI host adaptor cards
- All SCSI bus devices

Thin Film on Silicon 2QSP / 2NBS-XX3 Dual Terminator

General Information

Dual Terminator networks are used to correctly terminate single-ended SCSI bus lines. The standard R1, R2 combination ensures that the high frequency component of a signal transition will see an impedance at the termination equal to the characteristic impedance of the line. Fabricated with Tantalum Nitride on Silicon, these resistors feature excellent stability, TCR and tracking performance. The JEDEC standard miniature packages offer the most space-efficient Dual Terminator resistor array available.

Package Schematic

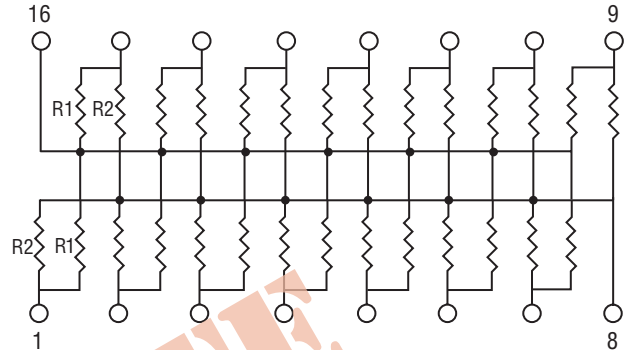

Electrical & Environmental Characteristics

Electrical Characteristics	Symbol	Minimum	Nominal	Maximum	Unit
Resistance Range	R	220		750	Ω
Tolerance:					
Absolute		$\pm 1\%$		$\pm 5\%$	Ω
Ratio		$\pm 0.5\%$		$\pm 2\%$	Ω
TCR:					
Absolute			100		ppm/ $^{\circ}\text{C}$
Tracking			25		ppm/ $^{\circ}\text{C}$
Operating Voltage				50	V
Environmental Characteristics					
ESD		2 K			V
Operating Temperature	T_J	-55		+125	$^{\circ}\text{C}$
Storage Temperature	T_{stg}	-65		+150	$^{\circ}\text{C}$
Power Rating per Resistor @ 70 $^{\circ}\text{C}$				0.1	Watt
Power Rating per Package @ 70 $^{\circ}\text{C}$:					
QSOP: 16 Pin				0.75	Watt
20, 24 Pin				1.00	Watt
28 Pin				1.12	Watt
NBSOIC: 8 Pin				0.60	Watt
14, 16 Pin				1.00	Watt

*RoHS Directive 2002/95/EC Jan 27, 2003 including Annex

Specifications are subject to change without notice.
Customers should verify actual device performance in their specific applications.

Thin Film on Silicon 2QSP / 2NBS -XX3 Dual Terminator

BOURNS®

Mechanical Characteristics

QSOP Package Dimensions

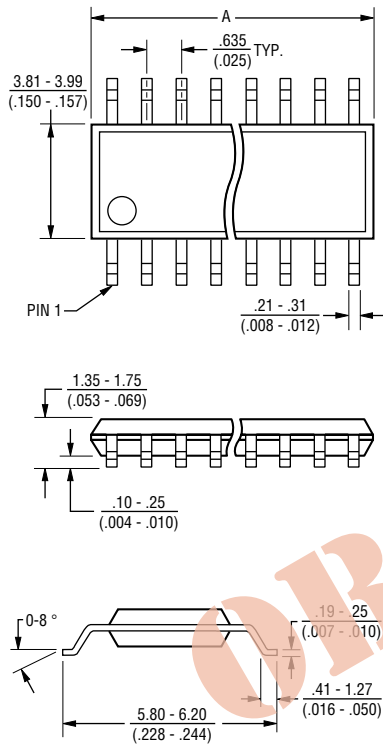

Model	A
2QSP16	4.80 - 4.98 (.189 - .196)
2QSP20	8.56 - 8.74 (.337 - .344)
2QSP24	8.56 - 8.74 (.337 - .344)
2QSP28	9.80 - 9.98 (.386 - .393)

Governing dimensions are in mm. Dimensions in parentheses are in inches and are approximate.

JEDEC Reference Number MO-137.

Narrow-Body SOIC Package Dimensions

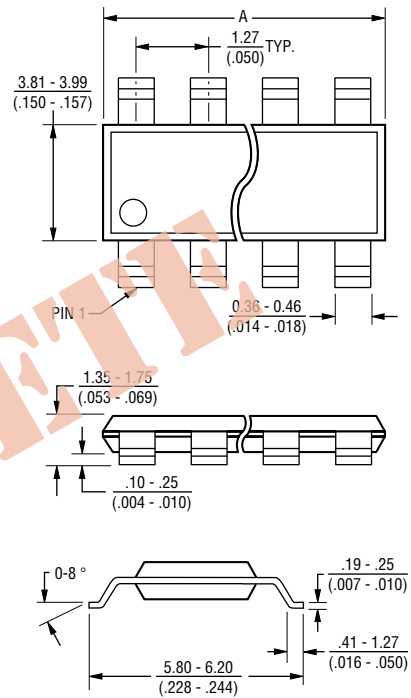

Model	A
2NBS08	4.80 - 4.98 (.189 - .196)
2NBS14	8.56 - 8.74 (.337 - .344)
2NBS16	9.80 - 9.98 (.386 - .393)

Governing dimensions are in mm. Dimensions in parentheses are in inches and are approximate.

JEDEC Reference Number MS-012.

Specifications are subject to change without notice. Customers should verify actual device performance in their specific applications.

Thin Film on Silicon 2QSP / 2NBS -XX3 Dual Terminator

BOURNS®

QSOP Package Power Temperature Derating Curve

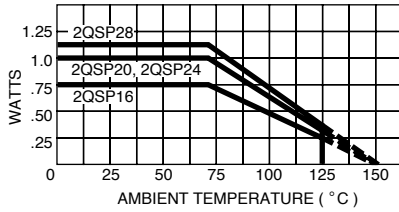

Narrow-Body SOIC Package Power Temperature Derating Curve

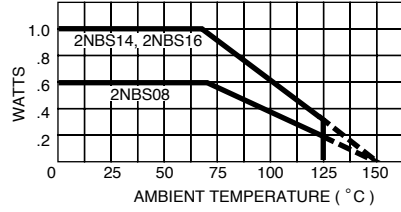

Schematic

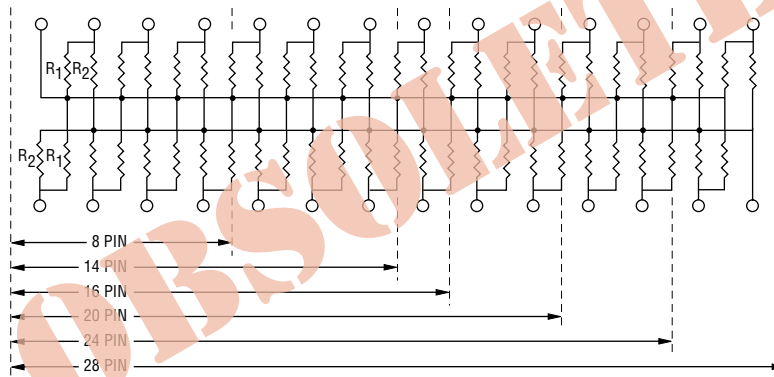

Typical Part Marking

Represents total content. Layout may vary.

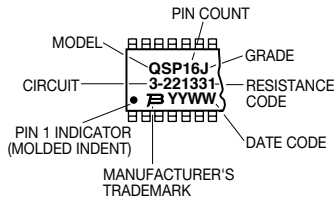

Standard Resistance Values

Resistor Designator	Resistance (ohms)	Resistance Code
R1	220	221
R2	330	331
R1	330	331
R2	680	681
R1	750	751
R2	750	751

Thin Film on Silicon 2QSP / 2NBS -XX3 Dual Terminator

BOURNS®

Dispensing

For large quantities, the product will be dispensed in Tape and Reel (see diagram below).

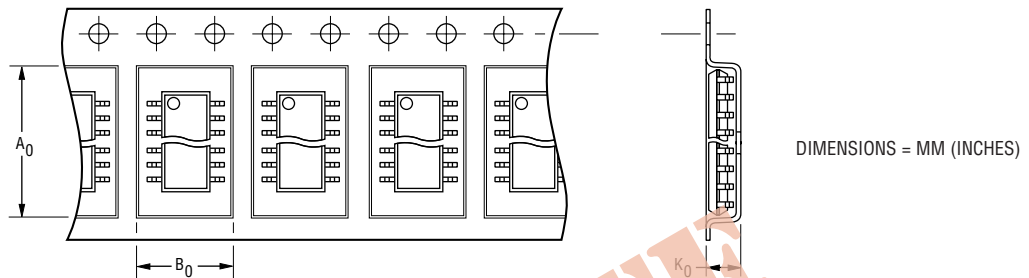

Package	A ₀	B ₀	K ₀	Width	Pitch	No. of Pieces per 13 reel	No. of Pieces per tube
QSOP							
16 Pin	6.4 (0.252)	5.2 (0.205)	2.1 (0.083)	12 (0.472)	8 (0.315)	3,500	98
20, 24 Pin	6.5 (0.256)	9.0 (0.354)	2.1 (0.083)	16 (0.630)	8 (0.315)	3,500	56
28 Pin	6.5 (0.256)	10.3 (0.406)	2.1 (0.083)	16 (0.630)	8 (0.315)	3,500	49
NBSOIC							
8 Pin	6.4 (0.252)	9.0 (0.354)	2.1 (0.083)	12 (0.472)	8 (0.315)	3,500	98
14 Pin	6.5 (0.256)	9.0 (0.354)	2.1 (0.083)	16 (0.630)	8 (0.315)	3,500	56
16 Pin	6.5 (0.256)	9.0 (0.354)	2.1 (0.083)	16 (0.630)	8 (0.315)	3,500	49

How To Order

2 QSP 20 - T J 3 221331 LF

Product Class _____
Thin-Film-on-Silicon

Standard Package Style _____
QSP = QSOP
NBS = Narrow-Body SOIC

Pin Count _____
QSP = 16, 20, 24, 28
NBS = 8, 14, 16

Dispensing _____
R = Reel
T = Tube

Standard Grade _____
Tolerance
J = ±5 %
G = ±2 %
F = ±1 %

Circuit _____
3 = Dual Terminator

Resistance Value Code _____
1st three digits specify R1 resistance code.
Last three digits specify R2 resistance code.

Terminations _____
• LF = 100 % Sn (RoHS Compliant)



Asia-Pacific:
Tel: +886-2 2562-4117 • Fax: +886-2 2562-4116

Europe:
Tel: +41-41 768 5555 • Fax: +41-41 768 5510

The Americas:
Tel: +1-951 781-5500 • Fax: +1-951 781-5700

www.bourns.com

REV. 11/10

Specifications are subject to change without notice.
Customers should verify actual device performance in their specific applications.