

Customer Information Sheet

DRAWING No.: D830XXB-XX SHEET 2 OF 2 IF IN DOUBT - ASK © NOT TO SCALE THIRD ANGLE PROJECTION ALL DIMENSIONS IN mm

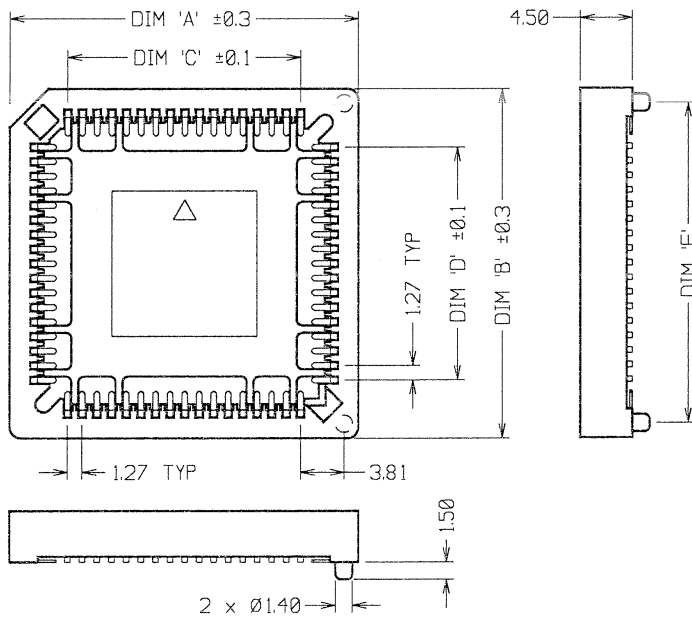

No. OF CONTACTS	DIM 'A'	DIM 'B'	DIM 'C'	DIM 'D'	DIM 'E'
20	15.66	15.66	5.08	5.08	12.70
28	18.20	18.20	7.62	7.62	15.24
32	18.20	20.74	7.62	10.16	17.78
44	23.28	23.28	12.70	12.70	20.32
52	25.82	25.82	15.24	15.24	22.86
68	30.90	30.90	20.32	20.32	27.94
84	35.98	35.98	25.40	25.40	33.02

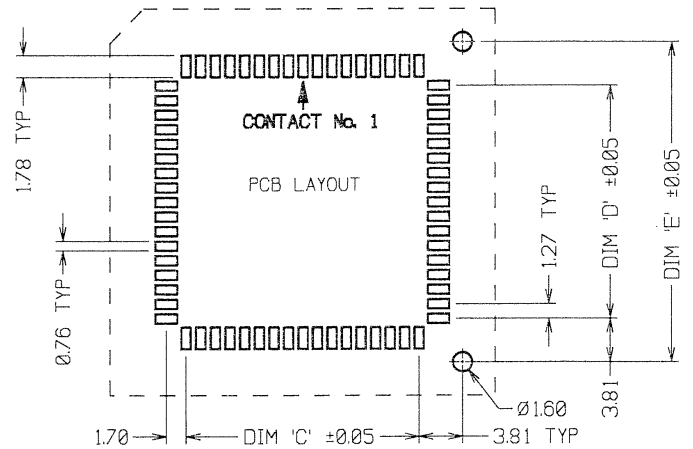

SPECIFICATION:

MATERIAL:
 MOULDING = PPS (BROWN) UL94V-0
 CONTACTS = PHOSPHOR BRONZE

FINISH:
 46 = 100% TIN

ELECTRICAL:
 CURRENT RATING = 1A
 WITHSTANDING VOLTAGE = 600V AC (1 MINUTE)
 CONTACT RESISTANCE = 30 MILLIOHMS MAX
 INSULATION RESISTANCE = 1000 MEGOHMS MIN

ENVIRONMENTAL:
 OPERATING TEMPERATURE = -50°C TO +105°C

PACKING: TUBE

NOTES:

- FOR ELECTRICAL AND MECHANICAL SPEC. SEE COMPONENT SPECIFICATION C020 (LATEST ISSUE).
- ALL TOLERANCES ARE ±0.20 UNLESS OTHERWISE STATED.

ORDER CODE:

D830XXB-XX

No. OF CONTACTS —
 (SEE TABLE)
 FINISH —
 46 = 100% TIN

JMB	10	17.10.06	9520
NAME	ISS.	DATE	C/NOTE
APPROVED: <i>[Signature]</i>			
CHECKED: <i>[Signature]</i>			
DRAWN: W. J. BOURNE			
CUSTOMER REF.:			
ASSEMBLY DRG.:			

HARWIN

THIS DRAWING AND ANY INFORMATION OR DESCRIPTIVE MATTER SET OUT HEREON ARE CONFIDENTIAL AND COPYRIGHT PROPERTY OF THE HARWIN GROUP AND MUST NOT BE DISCLOSED, LOANED, COPIED OR USED FOR MANUFACTURING, TENDERING OR FOR ANY OTHER PURPOSE WITHOUT THEIR WRITTEN PERMISSION.

TOLERANCES
 X = ±1mm
 X.X = ±0.25mm
 X.XX = ±0.10mm
 X.XXX = ±0.01mm
 ANGLES = ±5°
 UNLESS STATED

MATERIAL: SEE ABOVE
FINISH: SEE ABOVE
S/AREA: mm²

TITLE: LOW PROFILE SMT PLCC SOCKET (WITH LOCATION PEGS)
DRAWING NUMBER: D830XXB-XX

HARWIN USA TEL: 603 893 5376 FAX: 603 893 5396 mis@harwin.com
 HARWIN Europe (UK) TEL: 023 9231 4545 FAX: 023 9231 4590 mis@harwin.co.uk
 HARWIN Asia TEL: +65 6 779 4909 FAX: +65 6 779 3868 mis@harwin.com.sg

SHT 2 OF 2