

Type 168/185 Metallized Polyester Radial Lead Capacitors

Radial Box Metallized Polyester Capacitors for Automatic Insertion

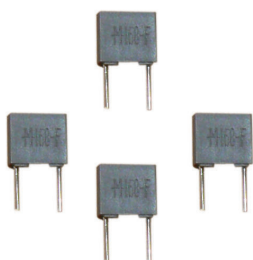

The Type 168/185 series radial lead metallized polyester box capacitors are available in bulk (Type 168) or on ammo pack or tape and reel (Type 185). These capacitors are constructed in rugged rectangular plastic cases and all come with 5.0 mm (0.197") lead spacing. They are good for general purpose applications such as bypass, decoupling, energy storage/discharge and arc suppression.

Highlights

- Case and epoxy fill meets UL94V-0
- 5.0 mm (0.197") lead spacing
- Bulk, tape and reel or ammo pack
- Non-inductively wound
- Non-polar
- Low leakage
- Lead material: Tinned copper wire

Specifications

RoHS Compliant

Capacitance Range: 0.001 μ F to 1.0 μ F

Voltage Range: 50 Vdc to 400 Vdc (30 Vac to 200 Vac, 60 Hz)

Capacitance Tolerance: \pm 5%, \pm 10%, \pm 20%

Operating Temperature Range: -55° C to $+125^{\circ}$ C (with 50% Vdc derating $>85^{\circ}$ C)

Dielectric Withstand Voltage: 1.6 x rated voltage for 2 sec @ $+25^{\circ}$ C \pm 5 $^{\circ}$ C

Dissipation Factor (DF): $\tan\delta \times 10^{-4}$ at 25° C \pm 5 $^{\circ}$ C

kHz	C \leq 0.1 μ F	C $>$ 0.1 μ F
1	\leq 100	\leq 100
10	\leq 150	\leq 150
100	\leq 300	

Total Self Inductance (L): Approximately 7 nH

Long Term Stability (after two years): Capacitance change $\Delta C/C \leq \pm 3\%$ under standard environmental conditions

Maximum Pulse Rise Time (dv/dt):

Vn	V/ μ s
50	250
63	250
100	300
250	400
400	600

If the working voltage (V) is less than the nominal voltage (Vn), the capacitor can work at higher dv/dt. In this case, the maximum value allowed is obtained by multiplying the above value with the ratio Vn/V.

Type 168/185 Metallized Polyester Radial Lead Capacitors

Capacitor Outline Drawing

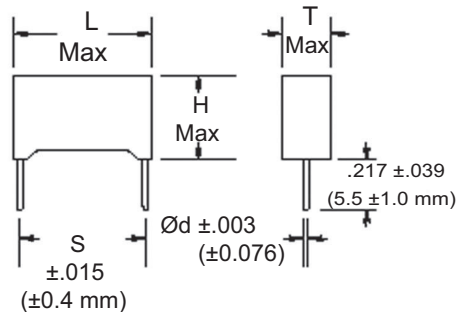

Test Method and Performance

Insulation Resistance	
Test Conditions	Temperature: 25 °C ±5 °C Voltage Charge Time: 1 minute Voltage Charge: 10 Vdc for Vn < 100 Vdc 100 Vdc for Vn ≥ 100 Vdc
Performance	For Vn > 100 Vdc: C ≤ 0.33 µF, ≥15,000 MΩ C > 0.33 µF, ≥ 5,000 S For Vn ≤ 100 Vdc: C ≤ 0.33 µF, 30,000 MΩ C > 0.33 µF, ≥ 10,000 S
Damp Heat Test	
Test Conditions	Temperature: +40 °C Relative Humidity: 95% Test Duration: 21 days
Performance	Capacitance Change ΔC/C: ±5% DF Change Δtgδ: ≤ 0.005 (10 KHz) Insulation Resistance: ≥ 50% of limit value
Life Test	
Test Conditions	REF Temperature: +85 °C Test Duration: 2000 hrs Voltage Applied: 1.25 x Vn
Performance	Capacitance Change ΔC/C: ≤ ±2% DF Change Δtgδ: ≤ 30 x 10 ⁻⁴ at 10 kHz Insulation Resistance: ≥ 50% of limit value

Soldering	
Test Conditions	Soldering Temperature: 260 °C ±5 °C Soldering Duration: 10 sec ±1 sec
Performance	Capacitance Change ΔC/C: ≤ ±2% DF Change Δtgδ: ≤ 30 x 10 ⁻⁴ at 10 kHz Insulation Resistance: ≥ limit value

Ratings

Catalog Part Number	Tape & Reel Ammo Pack	Cap (µF)	Inches					Millimeters				
			L	T	H	S	Ød	L	T	H	S	Ød
50 Vdc / 30 Vac												
168104*50A-F	185104*50#A>-F	0.10	0.283	0.098	0.256	0.197	0.020	7.2	2.5	6.5	5.0	5.0
168154*50A-F	185154*50#A>-F	0.15	0.283	0.098	0.256	0.197	0.020	7.2	2.5	6.5	5.0	5.0
168224*50C-F	185224*50#C>-F	0.22	0.283	0.138	0.295	0.197	0.020	7.2	3.5	7.5	5.0	5.0
168334*50C-F	185334*50#C>-F	0.33	0.283	0.138	0.295	0.197	0.020	7.2	3.5	7.5	5.0	5.0
168474*50H-F	185474*50#H>-F	0.47	0.283	0.138	0.295	0.197	0.020	7.2	3.5	7.5	5.0	5.0
168684*50F-F	185684*50#F>-F	0.68	0.283	0.236	0.433	0.197	0.024	7.2	6.0	11.0	5.0	6.0
168824*50G-F	185824*50#G>-F	0.82	0.283	0.236	0.433	0.197	0.024	7.2	6.0	11.0	5.0	6.0
168105*50G-F	185105*50#G>-F	1.00	0.283	0.236	0.433	0.197	0.024	7.2	6.0	11.0	5.0	6.0
63 Vdc / 40 Vac												
168473*63A-F	185473*63#A>-F	0.047	0.283	0.098	0.256	0.197	0.020	7.2	2.5	6.5	5.0	5.0
168563*63A-F	185563*63#A>-F	0.056	0.283	0.098	0.256	0.197	0.020	7.2	2.5	6.5	5.0	5.0
168683*63A-F	185683*63#A>-F	0.068	0.283	0.098	0.256	0.197	0.020	7.2	2.5	6.5	5.0	5.0
168823*63A-F	185823*63#A>-F	0.082	0.283	0.098	0.256	0.197	0.020	7.2	2.5	6.5	5.0	5.0
168104*63A-F	185104*63#A>-F	0.10	0.283	0.098	0.256	0.197	0.020	7.2	2.5	6.5	5.0	5.0
168154*63C-F	185154*63#C>-F	0.15	0.283	0.138	0.295	0.197	0.020	7.2	3.5	7.5	5.0	5.0
168184*63C-F	185184*63#C>-F	0.18	0.283	0.138	0.295	0.197	0.020	7.2	3.5	7.5	5.0	5.0
168224*63C-F	185224*63#C>-F	0.22	0.283	0.138	0.295	0.197	0.020	7.2	3.5	7.5	5.0	5.0
168274*63C-F	185274*63#C>-F	0.27	0.283	0.098	0.256	0.197	0.020	7.2	2.5	6.5	5.0	5.0
168334*63H-F	185334*63#H>-F	0.33	0.283	0.138	0.295	0.197	0.020	7.2	3.5	7.5	5.0	5.0
168474*63H-F	185474*63#H>-F	0.47	0.283	0.138	0.295	0.197	0.020	7.2	3.5	7.5	5.0	5.0
168684*63F-F	185684*63#F>-F	0.68	0.283	0.177	0.374	0.197	0.024	7.2	4.5	9.5	5.0	6.0
168105*63G-F	185105*63#G>-F	1.00	0.283	0.236	0.433	0.197	0.024	7.2	6.0	11.0	5.0	6.0

RoHS Compliant

* Indicates capacitance tolerance: J = ±5%, K = ±10%, M = ±20%
 # Indicates packaging type: R = Tape and Reel, A = Ammo Pack
 > Indicates tooling code: A = 16.5 mm, B = 18.5 mm (See H dimension in taping specifications)

Type 168/185 Metallized Polyester Radial Lead Capacitors

RoHS
Compliant

Catalog Part Number	Tape & Reel Ammo Pack	Cap (µF)	Inches					Millimeters				
			L	T	H	S	Ød	L	T	H	S	Ød
100 Vdc / 63 Vac												
168102*100A-F	185102*100#A>-F	0.0010	0.283	0.098	0.256	0.197	0.020	7.2	2.5	6.5	5.0	0.5
168152*100A-F	185152*100#A>-F	0.0015	0.283	0.098	0.256	0.197	0.020	7.2	2.5	6.5	5.0	0.5
168222*100A-F	185222*100#A>-F	0.0022	0.283	0.098	0.256	0.197	0.020	7.2	2.5	6.5	5.0	0.5
168272*100A-F	185272*100#A>-F	0.0027	0.283	0.098	0.256	0.197	0.020	7.2	2.5	6.5	5.0	0.5
168332*100A-F	185332*100#A>-F	0.0033	0.283	0.098	0.256	0.197	0.020	7.2	2.5	6.5	5.0	0.5
168392*100A-F	185392*100#A>-F	0.0039	0.283	0.098	0.256	0.197	0.020	7.2	2.5	6.5	5.0	0.5
168472*100A-F	185472*100#A>-F	0.0047	0.283	0.098	0.256	0.197	0.020	7.2	2.5	6.5	5.0	0.5
168562*100A-F	185562*100#A>-F	0.0056	0.283	0.098	0.256	0.197	0.020	7.2	2.5	6.5	5.0	0.5
168682*100A-F	185682*100#A>-F	0.0068	0.283	0.098	0.256	0.197	0.020	7.2	2.5	6.5	5.0	0.5
168822*100A-F	185822*100#A>-F	0.0082	0.283	0.098	0.256	0.197	0.020	7.2	2.5	6.5	5.0	0.5
168103*100A-F	185103*100#A>-F	0.010	0.283	0.098	0.256	0.197	0.020	7.2	2.5	6.5	5.0	0.5
168153*100A-F	185153*100#A>-F	0.015	0.283	0.098	0.256	0.197	0.020	7.2	2.5	6.5	5.0	0.5
168183*100A-F	185183*100#A>-F	0.018	0.283	0.098	0.256	0.197	0.020	7.2	2.5	6.5	5.0	0.5
168223*100A-F	185223*100#A>-F	0.022	0.283	0.098	0.256	0.197	0.020	7.2	2.5	6.5	5.0	0.5
168273*100A-F	185273*100#A>-F	0.027	0.283	0.098	0.256	0.197	0.020	7.2	2.5	6.5	5.0	0.5
168333*100C-F	185333*100#C>-F	0.033	0.283	0.098	0.256	0.197	0.020	7.2	2.5	6.5	5.0	0.5
168393*100C-F	185393*100#C>-F	0.039	0.283	0.098	0.256	0.197	0.020	7.2	2.5	6.5	5.0	0.5
168473*100C-F	185473*100#C>-F	0.047	0.283	0.098	0.256	0.197	0.020	7.2	2.5	6.5	5.0	0.5
168683*100H-F	185683*100#H>-F	0.068	0.283	0.098	0.256	0.197	0.020	7.2	2.5	6.5	5.0	0.5
168104*100H-F	185104*100#H>-F	0.10	0.283	0.098	0.256	0.197	0.020	7.2	2.5	6.5	5.0	0.5
168154*100F-F	185154*100#F>-F	0.15	0.283	0.177	0.374	0.197	0.024	7.2	4.5	9.5	5.0	0.6
168224*100G-F	185224*100#G>-F	0.22	0.283	0.197	0.394	0.197	0.024	7.2	5.0	10.0	5.0	0.6
250 Vdc / 160 Vac												
168332*250A-F	185332*250#A>-F	0.0033	0.283	0.098	0.256	0.197	0.020	7.2	2.5	6.5	5.0	0.5
168472*250A-F	185472*250#A>-F	0.0047	0.283	0.098	0.256	0.197	0.020	7.2	2.5	6.5	5.0	0.5
168682*250A-F	185682*250#A>-F	0.0068	0.283	0.098	0.256	0.197	0.020	7.2	2.5	6.5	5.0	0.5
168103*250A-F	185103*250#A>-F	0.010	0.283	0.098	0.256	0.197	0.020	7.2	2.5	6.5	5.0	0.5
168153*250A-F	185153*250#A>-F	0.015	0.283	0.098	0.256	0.197	0.020	7.2	2.5	6.5	5.0	0.5
168223*250C-F	185223*250#C>-F	0.022	0.283	0.138	0.295	0.197	0.020	7.2	3.5	7.5	5.0	0.5
168333*250C-F	185333*250#C>-F	0.033	0.283	0.138	0.295	0.197	0.020	7.2	3.5	7.5	5.0	0.5
168473*250F-F	185473*250#F>-F	0.047	0.283	0.177	0.374	0.197	0.024	7.2	4.5	9.5	5.0	0.6
168683*250F-F	185683*250#F>-F	0.068	0.283	0.177	0.374	0.197	0.024	7.2	4.5	9.5	5.0	0.6
168104*250G-F	185104*250#G>-F	0.100	0.283	0.197	0.394	0.197	0.024	7.2	5.0	10	5.0	0.6
400 Vdc / 200 Vac												
168102*400A-F	185102*400#A>-F	0.001	0.283	0.098	0.256	0.197	0.020	7.2	2.5	6.5	5.0	0.5
168152*400A-F	185152*400#A>-F	0.0015	0.283	0.098	0.256	0.197	0.020	7.2	2.5	6.5	5.0	0.5
168222*400A-F	185222*400#A>-F	0.0022	0.283	0.098	0.256	0.197	0.020	7.2	2.5	6.5	5.0	0.5
168332*400C-F	185332*400#C>-F	0.0033	0.283	0.098	0.256	0.197	0.020	7.2	2.5	6.5	5.0	0.5
168472*400C-F	185472*400#C>-F	0.0047	0.283	0.098	0.256	0.197	0.020	7.2	2.5	6.5	5.0	0.5
168682*400C-F	185682*400#C>-F	0.0068	0.283	0.138	0.295	0.197	0.020	7.2	3.5	7.5	5.0	0.5
168103*400F-F	185103*400#F>-F	0.010	0.283	0.138	0.295	0.197	0.020	7.2	3.5	7.5	5.0	0.5
168153*400F-F	185153*400#F>-F	0.015	0.283	0.177	0.374	0.197	0.024	7.2	4.5	9.5	5.0	0.6
168223*400G-F	185223*400#G>-F	0.022	0.283	0.197	0.394	0.197	0.024	7.2	5.0	10	5.0	0.6

* Indicates capacitance tolerance: J = ±5%, K = ±10%, M = ±20%

Indicates packaging type: R = Tape and Reel, A = Ammo Pack

> Indicates tooling code: A = 16.5 mm, B = 18.5 mm (See H dimension in taping specification)

Type 168/185 Metallized Polyester Radial Lead Capacitors

Tape Specification - 5.0 mm Lead Spacing

Standard EIA-468-B

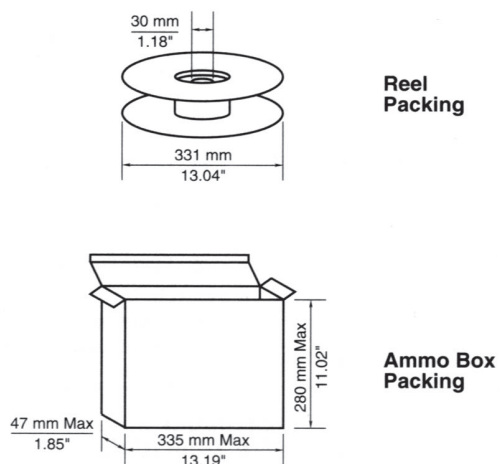
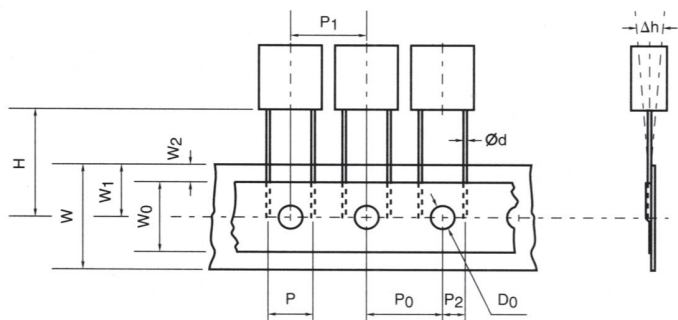

Item	Code	Millimeters	Inches
Lead-to-Lead Distance	P	5.0 ^{+0.6 -0.2}	.197 ^{+0.024 -.040}
Feed Hole Pitch	P ₀	12.7 ^{±0.3}	.5 ^{±0.12}
Pitch of Component	P ₁	12.7 ^{±1.0}	.5 ^{+0.39}
Hole Center to Lead	P ₂	2.54 ^{±0.7}	.100 ^{±0.28}
Feed Hole Center to Component Center	P ₃	6.35 ^{±1.3}	.250 ^{±0.51}
Component Alignment, F-R	Δh	0 ^{±2.0}	0 ^{±0.79}
Tape Width	W	18 ^{+1.0 -0.1}	.709 ^{+0.39 -.004}
Hold-down Tape Width	W ₀	6.0 min	.236 min
Hole Position	W ₁	9.0 ^{+0.75 -0.05}	.355 ^{+0.30 -.001}
Hold-down Tape Position	W ₂	3.0 Max	.118 Max
Height of Component from Tape Center	H	>	>
Feed Hole Diameter	D ₀	4.0 ^{±0.3}	.157 ^{±0.12}

Case Thickness T	Quantity Reeled	Quantity Ammo Pack
2.5	2500	2000
3.5	1800	1500
4.5	1400	1300
5	1200	1000
6	1000	800

> The H dimension depends on the insertion equipment used. Specify the proper tooling code as indicated below.

Tooling Code	H Dimensions	
	Millimeters	Inches
A	16.5 ^{±0.75}	.679 ^{±0.030}
B	18.5 ^{±0.75}	.728 ^{±0.030}

Part Numbering System for Auto Insertion

168/185	104	K	100	R	H	B	-F
Series	Capacitance	Tolerance	Voltage	Package Type (#)	Internal Code	*Tooling Code (>)	RoHS Compliant Designation
185	102 = .001 μF	J = ±5%	50 = 50 Vdc	A = Ammo	Letter	A	
	103 = .01 μF	K = ±10%	63 = 63 Vdc	R = Tape & Reel		B	
	104 = .1 μF	M = ±20%	100 = 100 Vdc				
	105 = 1.0 μF		250 = 250 Vdc				
			400 = 400 Vdc				

* Tooling code (>) depends on the users insertion equipment requirements. See table for available options.