

1

2

3

4

5

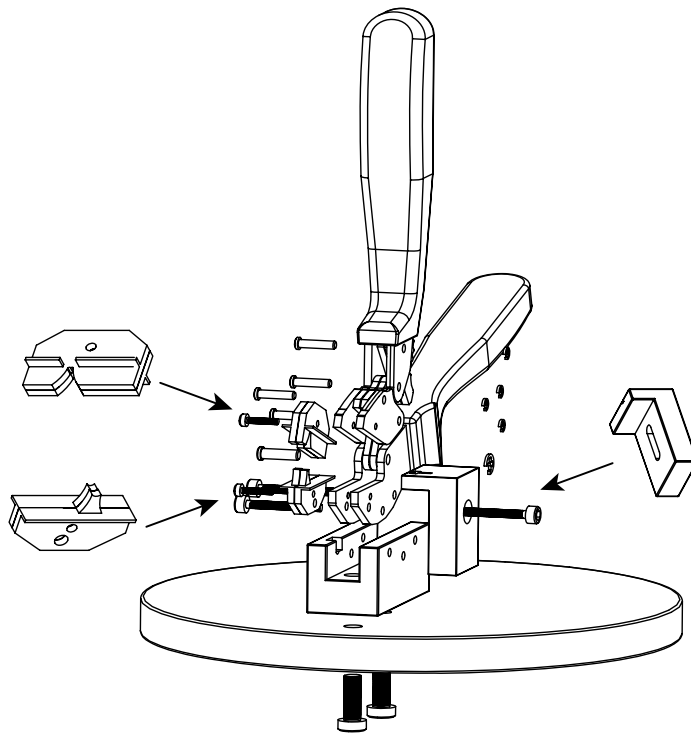



#### CHARACTERISTICS

- TOOL FOR WIRE ASSEMBLY WITH CRIMPING TERMINAL
- DESIGNED FOR HAND USE
- EASY PROCESS - DO NOT REQUIRE STRONG PRESSURE
- CRIMPING QUALITY SIMILAR TO AUTOMATIC MOUNTING

#### INSTRUCTIONS FOR USE:

- INTRODUCE THE TERMINAL INTO DIE'S CAVITY
- PUT CORRECTLY THE WIRE INTO THE TERMINAL
- PRESS THE HANDLE
- REMOVE THE CRIMPED WIRE

RoHS Compliant

G				PROJECTION: 	GENERAL TOLERANCE .X = +/- 0.2 .XX = +/- 0.15		DESCRIPTION: MPC3 HAND PLIER FOR FEMALE CRIMP TERMINAL (66200113722) WIRE 24-20 AWG (0.20 TO 0.52MM <sup>2</sup> )	SIZE <b>A4</b>
F								
E								
D								
C	19-FEB-08	DESCRIPTION	CH	APPROVAL: RJ	UNIT: MM	WERI PART NO: 600662220241		
B	23-DEC-07	DESCRIPTION	EC		SCALE:			
A	24-APR-07	PDF	JPP		SHEET: 1/1			
REV	DATE	FILE	BY		DRAW: CH			