

MATERIAL NO.	ENG. NO.	STUD SIZE	"S"±.003	MATERIAL	PLATING
190840001	SRZ-0129-06	6	.146/3.71	BRASS	NONE
190840002	SRZ-0129-08	8	.173/4.39		
190840003	SRZ-0129-10	10	.198/5.03		
190840004	SRZ-4129-06	6	.146/3.71	BRASS	TIN
190840005	SRZ-4129-08	8	.173/4.39		
190840006	SRZ-4129-10	10	.198/5.03		
190840007	SRZ-S-4129-06	6	.146/3.71	STEEL	TIN
190840008	SRZ-S-4129-08	8	.173/4.39		
190840009	SRZ-S-4129-10	10	.198/5.03		

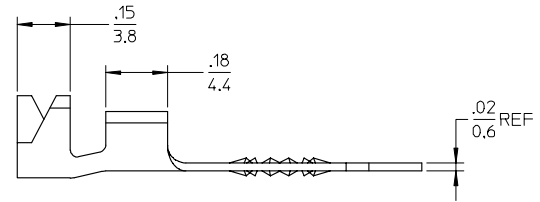
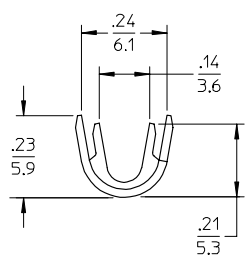
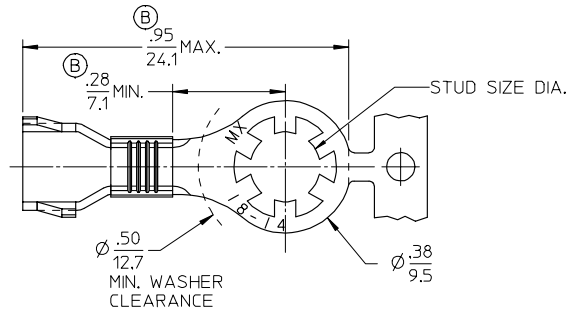

SALES DRAWING

NOTE(S):
 1. WIRE: SIZE: 18-14 AWG
 0.7 - 2.6 MM²

UPDATE TO MX STDS EC NO: ETC2001-0128 DRAWN BY: RICK 2005/02/18 CHECKED: PAUL LCK 2005/02/18 APPR: PAUL LCK 2005/02/18	QUALITY SYMBOLS ▽=0 ▽=0	GENERAL TOLERANCES (UNLESS SPECIFIED)		DIMENSION STYLE IN/MM		SCALE	DESIGN UNITS INCH	THIRD ANGLE PROJECTION		
		4 PLACES ± --- ± ---	3 PLACES ± --- ± .005	2 PLACES ± 0.13 ± .01	1 PLACE ± 0.25 ± ---	ANGULAR ± 1/2°	DRAWN BY: JHACKNEY DATE: 1995/05/05	CHECKED BY: RDEROSS DATE: 1995/05/05	TITLE: OPEN BARREL STRIP STAR RING, VIBRAKRIMP 18-14 AWG	
		DRAFT WHERE APPLICABLE MUST REMAIN WITHIN DIMENSIONS				MATERIAL NO. SEE CHART	APPROVED BY: RDEROSS DATE: 1995/05/05	MOLEX INCORPORATED		SHEET NO. 1 OF 1
		THIS DRAWING CONTAINS INFORMATION THAT IS PROPRIETARY TO MOLEX INCORPORATED AND SHOULD NOT BE USED WITHOUT WRITTEN PERMISSION								