

SYNCHRONOUS PRESETTABLE 4-BIT COUNTER

- HIGH SPEED:
 $f_{MAX} = 125\text{MHz}$ (TYP.) at $V_{CC} = 5\text{V}$
- LOW POWER DISSIPATION:
 $I_{CC} = 8\mu\text{A}$ (MAX.) at $T_A = 25^\circ\text{C}$
- HIGH NOISE IMMUNITY:
 $V_{NIH} = V_{NIL} = 28\% V_{CC}$ (MIN.)
- 50Ω TRANSMISSION LINE DRIVING CAPABILITY
- SYMMETRICAL OUTPUT IMPEDANCE:
 $|I_{OH}| = I_{OL} = 24\text{mA}$ (MIN)
- BALANCED PROPAGATION DELAYS:
 $t_{PLH} \cong t_{PHL}$
- OPERATING VOLTAGE RANGE:
 V_{CC} (OPR) = 2V to 6V
- PIN AND FUNCTION COMPATIBLE WITH 74 SERIES 161
- IMPROVED LATCH-UP IMMUNITY

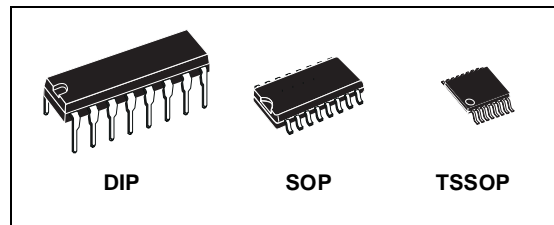

ORDER CODES

PACKAGE	TUBE	T & R
DIP	74AC161B	
SOP	74AC161M	74AC161MTR
TSSOP		74AC161TTR

DESCRIPTION

The 74AC161 is an advanced high-speed CMOS SYNCHRONOUS PRESETTABLE COUNTER fabricated with sub-micron silicon gate and double-layer metal wiring C²MOS technology. It is a 4 bit binary counter with Asynchronous Clear.

The circuit have four fundamental modes of operation, in order of preference: synchronous reset, parallel load, count-up and hold. Four control inputs, (CLEAR), (LOAD), (PE) and (TE), determine the mode of operation as shown in the Truth Table. A LOW signal on CLEAR overrides

counting and parallel loading and sets all outputs on LOW state. A LOW signal on LOAD overrides counting and allows information on Parallel Data inputs to be loaded into the flip-flop on the next rising edge of CLOCK. With LOAD and CLEAR HIGH, PE and TE permit counting when both are HIGH. Conversely, a LOW signal on either PE and TE inhibits counting.

The CARRY OUTPUT is HIGH when TE is HIGH and counter is in state 15.

All inputs and outputs are equipped with protection circuits against static discharge, giving them 2KV ESD immunity and transient excess voltage.

PIN CONNECTION AND IEC LOGIC SYMBOLS

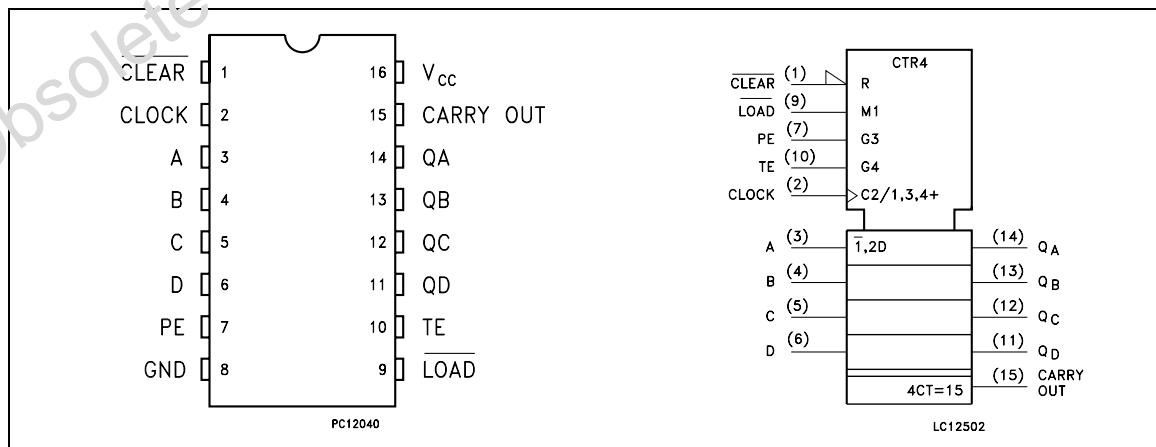

74AC161

INPUT AND OUTPUT EQUIVALENT CIRCUIT

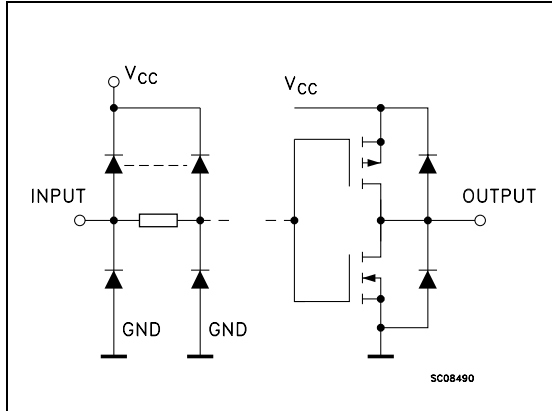

PIN DESCRIPTION

PIN No	SYMBOL	NAME AND FUNCTION
1	CLEAR	Master Reset
2	CLOCK	Clock Input (LOW to HIGH Edge Trigger)
3, 4, 5, 6	A, B, C, D	Data Inputs
7	PE	Count Enable Input
10	TE	Count Enable Carry Input
9	LOAD	Parallel Enable Input
14, 13, 12, 11	QA to QD	Flip-Flop Outputs
15	CARRY OUT	Terminal Count Output
8	GND	Ground (0V)
16	V _{CC}	Positive Supply Voltage

TRUTH TABLE

INPUTS					OUTPUTS				FUNCTION
CLEAR	LOAD	PE	TE	CK					
L	X	X	X	X	L	L	L	L	PRESET TO "0"
H	L	X	X		A	B	C	D	PRESET DATA
H	H	X	L		NO CHANGE				NO COUNT
H	H	L	X		NO CHANGE				NO COUNT
H	H	H	H		COUNT UP				COUNT
H	X	X	X		NO CHANGE				NO COUNT

X : Don't Care; A, B, C, D; Logic level of data input; CARRY OUT : TE x QA x QB x QC x QD

LOGIC DIAGRAM

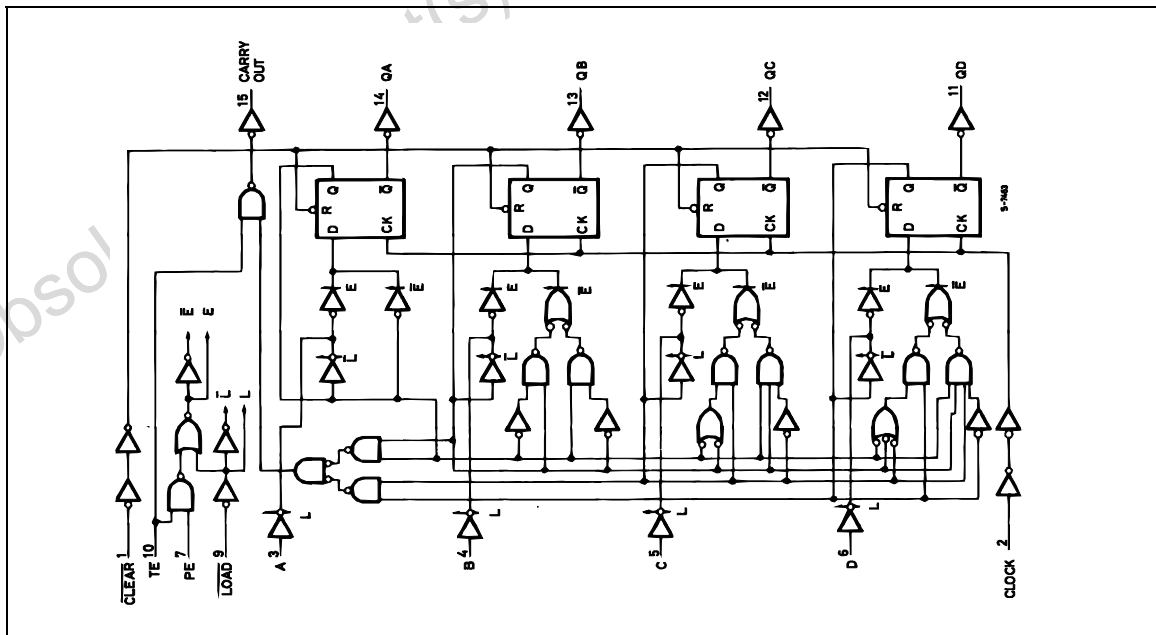

TIMING CHART

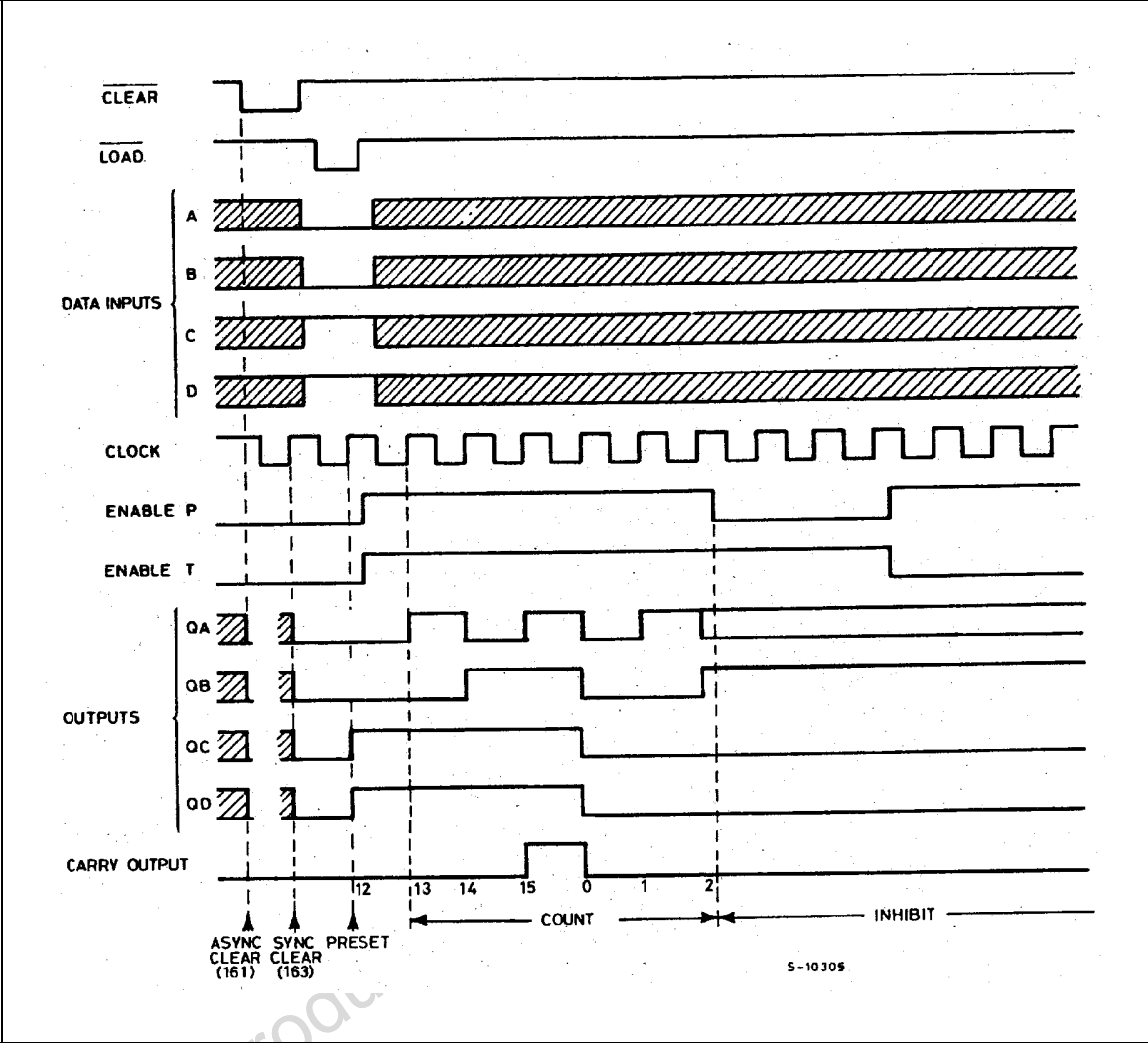

ABSOLUTE MAXIMUM RATINGS

Symbol	Parameter	Value	Unit
V_{CC}	Supply Voltage	-0.5 to +7	V
V_I	DC Input Voltage	-0.5 to $V_{CC} + 0.5$	V
V_O	DC Output Voltage	-0.5 to $V_{CC} + 0.5$	V
I_{IK}	DC Input Diode Current	± 20	mA
I_{OK}	DC Output Diode Current	± 20	mA
I_O	DC Output Current	± 50	mA
I_{CC} or I_{GND}	DC V_{CC} or Ground Current	± 300	mA
T_{stg}	Storage Temperature	-65 to +150	°C
T_L	Lead Temperature (10 sec)	300	°C

Absolute Maximum Ratings are those values beyond which damage to the device may occur. Functional operation under these conditions is not implied.

RECOMMENDED OPERATING CONDITIONS

Symbol	Parameter	Value	Unit
V_{CC}	Supply Voltage	2 to 6	V
V_I	Input Voltage	0 to V_{CC}	V
V_O	Output Voltage	0 to V_{CC}	V
T_{op}	Operating Temperature	-55 to 125	°C
dt/dv	Input Rise and Fall Time $V_{CC} = 3.0, 4.5$ or $5.5V$ (note 1)	8	ns/V

1) V_{IN} from 30% to 70% of V_{CC}

DC SPECIFICATIONS

Symbol	Parameter	Test Condition		Value						Unit	
		V _{CC} (V)		T _A = 25°C			-40 to 85°C		-55 to 125°C		
				Min.	Typ.	Max.	Min.	Max.	Min.		Max.
V _{IH}	High Level Input Voltage	3.0	V _O = 0.1 V or V _{CC} -0.1V	2.1	1.5		2.1		2.1		V
		4.5		3.15	2.25		3.15		3.15		
		5.5		3.85	2.75		3.85		3.85		
V _{IL}	Low Level Input Voltage	3.0	V _O = 0.1 V or V _{CC} -0.1V		1.5	0.9		0.9		0.9	V
		4.5			2.25	1.35		1.35		1.35	
		5.5			2.75	1.65		1.65		1.65	
V _{OH}	High Level Output Voltage	3.0	I _O = -50 μA	2.9	2.99		2.9		2.9		V
		4.5	I _O = -50 μA	4.4	4.49		4.4		4.4		
		5.5	I _O = -50 μA	5.4	5.49		5.4		5.4		
		3.0	I _O = -12 mA	2.56			2.46		2.4		
		4.5	I _O = -24 mA	3.86			3.76		3.7		
		5.5	I _O = -24 mA	4.86			4.76		4.7		
V _{OL}	Low Level Output Voltage	3.0	I _O = 50 μA		0.002	0.1		0.1		0.1	V
		4.5	I _O = 50 μA		0.001	0.1		0.1		0.1	
		5.5	I _O = 50 μA		0.001	0.1		0.1		0.1	
		3.0	I _O = 12 mA			0.36		0.44		0.5	
		4.5	I _O = 24 mA			0.36		0.44		0.5	
		5.5	I _O = 24 mA			0.36		0.44		0.5	
I _I	Input Leakage Current	5.5	V _I = V _{CC} or GND			± 0.1		± 1		± 1	μA
I _{CC}	Quiescent Supply Current	5.5	V _I = V _{CC} or GND			8		80		160	μA
I _{OLD}	Dynamic Output Current (note 1, 2)	5.5	V _{OLD} = 1.65 V max					75		50	mA
I _{OHD}			V _{OHD} = 3.85 V min					-75		-50	mA

1) Maximum test duration 2ms, one output loaded at time

2) Incident wave switching is guaranteed on transmission lines with impedances as low as 50Ω

AC ELECTRICAL CHARACTERISTICS ($C_L = 50 \text{ pF}$, $R_L = 500 \Omega$, Input $t_r = t_f = 3\text{ns}$)

Symbol	Parameter	Test Condition		Value						Unit	
		V_{CC} (V)		$T_A = 25^\circ\text{C}$			$-40 \text{ to } 85^\circ\text{C}$		$-55 \text{ to } 125^\circ\text{C}$		
				Min.	Typ.	Max.	Min.	Max.	Min.		Max.
t_{PLH} t_{PHL}	Propagation Delay Time CLOCK to Q	3.3 ^(*)			7.0	12.0		13.0		13.0	ns
		5.0 ^(**)			5.0	9.0		10.0		10.0	
t_{PLH} t_{PHL}	Propagation Delay Time CLOCK to CARRY OUT	3.3 ^(*)			8.5	14.0		15.0		15.0	ns
		5.0 ^(**)			6.0	10.0		11.0		11.0	
t_{PLH} t_{PHL}	Propagation Delay Time TE to CARRY OUT	3.3 ^(*)			5.5	9.5		11.0		11.0	ns
		5.0 ^(**)			3.5	6.5		7.5		7.5	
t_{PHL}	Propagation Delay Time CLEAR to Q	3.3 ^(*)			6.5	12.0		13.0		13.0	ns
		5.0 ^(**)			5.5	9.0		10.0		10.0	
t_{PHL}	Propagation Delay Time CLEAR to CARRY OUT	3.3 ^(*)			7.0	12.0		13.0		13.0	ns
		5.0 ^(**)			5.5	9.5		10.0		10.0	
t_{WL}	CLEAR Pulse Width LOW	3.3 ^(*)			3.0	5.5		7.5		7.5	ns
		5.0 ^(**)			2.5	4.5		6.0		6.0	
t_{W}	CLOCK Pulse Width HIGH or LOW	3.3 ^(*)			2.0	3.5		4.0		4.0	ns
		5.0 ^(**)			2.0	3.0		3.5		3.5	
t_s	Setup Time HIGH or LOW (INPUT to CLOCK)	3.3 ^(*)			4.0	13.5		16.0		16.0	ns
		5.0 ^(**)			1.5	8.5		10.5		10.5	
t_h	Hold Time HIGH or LOW (INPUT to CLOCK)	3.3 ^(*)			-1.0	-1.0		0.5		0.5	ns
		5.0 ^(**)			-0.5	0.5		1.0		1.0	
t_s	Setup Time HIGH or LOW (CLEAR to CLOCK)	3.3 ^(*)			3.0	11.5		14.0		14.0	ns
		5.0 ^(**)			2.0	7.5		8.5		8.5	
t_h	Hold Time HIGH or LOW (CLEAR to CLOCK)	3.3 ^(*)			-2.5	0		0		0	ns
		5.0 ^(**)			-2.0	0.5		1.0		1.0	
t_s	Setup Time HIGH or LOW (PE or TE to CLOCK)	3.3 ^(*)			3.0	6.0		7.0		7.0	ns
		5.0 ^(**)			2.0	4.5		5.0		5.0	
t_h	Hold Time HIGH or LOW (PE or TE to CLOCK)	3.3 ^(*)			-1.0	0		0		0	ns
		5.0 ^(**)			-0.5	0		0.5		0.5	
t_{REM}	Recovery Time (CLEAR to CLOCK)	3.3 ^(*)			-1.0	0		0.5		0.5	ns
		5.0 ^(**)			-0.5	0.5		1.0		1.0	
f_{MAX}	Maximum Clock Frequency	3.3 ^(*)			70	90		60		60	MHz
		5.0 ^(**)			110	125		95		95	

(*) Voltage range is $3.3\text{V} \pm 0.3\text{V}$ (**) Voltage range is $5.0\text{V} \pm 0.5\text{V}$

CAPACITIVE CHARACTERISTICS

Symbol	Parameter	Test Condition		Value						Unit	
				$T_A = 25^\circ\text{C}$			-40 to 85°C		-55 to 125°C		
		V_{CC} (V)		Min.	Typ.	Max.	Min.	Max.	Min.		Max.
C_{IN}	Input Capacitance	5.0			4.5						pF
C_{PD}	Power Dissipation Capacitance (note1)	5.0	$f_{IN} = 10\text{MHz}$		18						pF

1) C_{PD} is defined as the value of the IC's internal equivalent capacitance which is calculated from the operating current consumption without load. (Refer to Test Circuit). Average operating current can be obtained by the following equation. $I_{CC(oper)} = C_{PD} \times V_{CC} \times f_{IN} + I_{CC}/n$ (per circuit)

TEST CIRCUIT

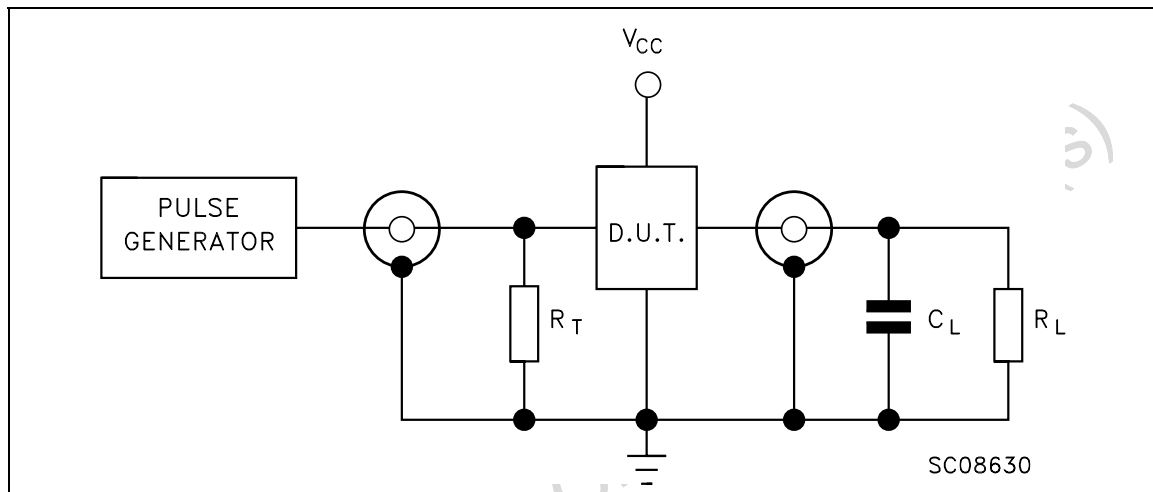

$C_L = 50\text{pF}$ or equivalent (includes jig and probe capacitance)

$R_L = R_1 = 500\Omega$ or equivalent

$R_T = Z_{OUT}$ of pulse generator (typically 50Ω)

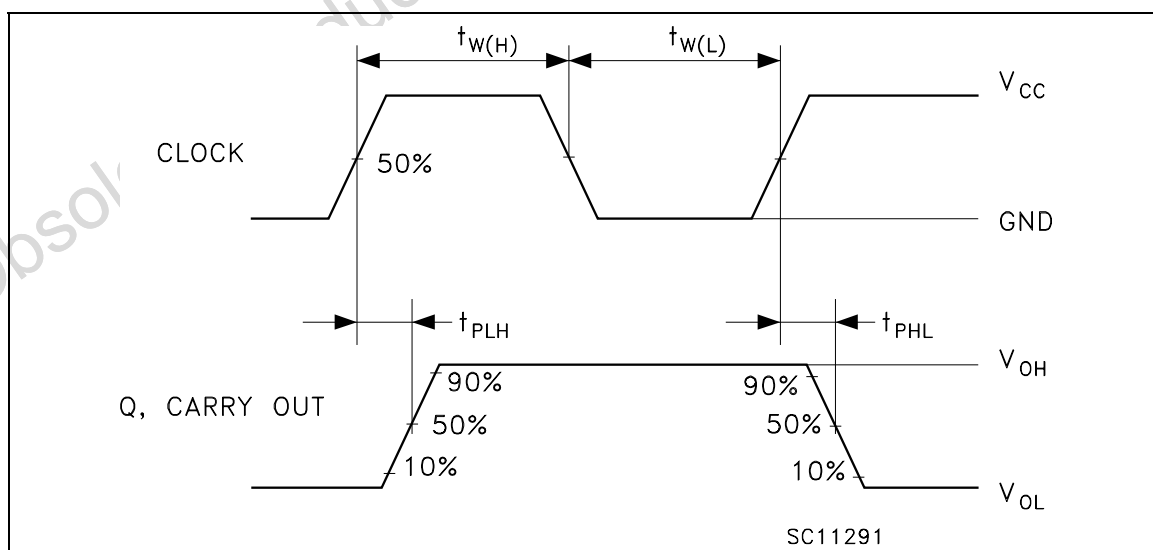
WAVEFORM 1: PROPAGATION DELAYS, COUNT MODE ($f=1\text{MHz}$; 50% duty cycle)

WAVEFORM 2: PROPAGATION DELAYS CLEAR MODE (f=1MHz; 50% duty cycle)

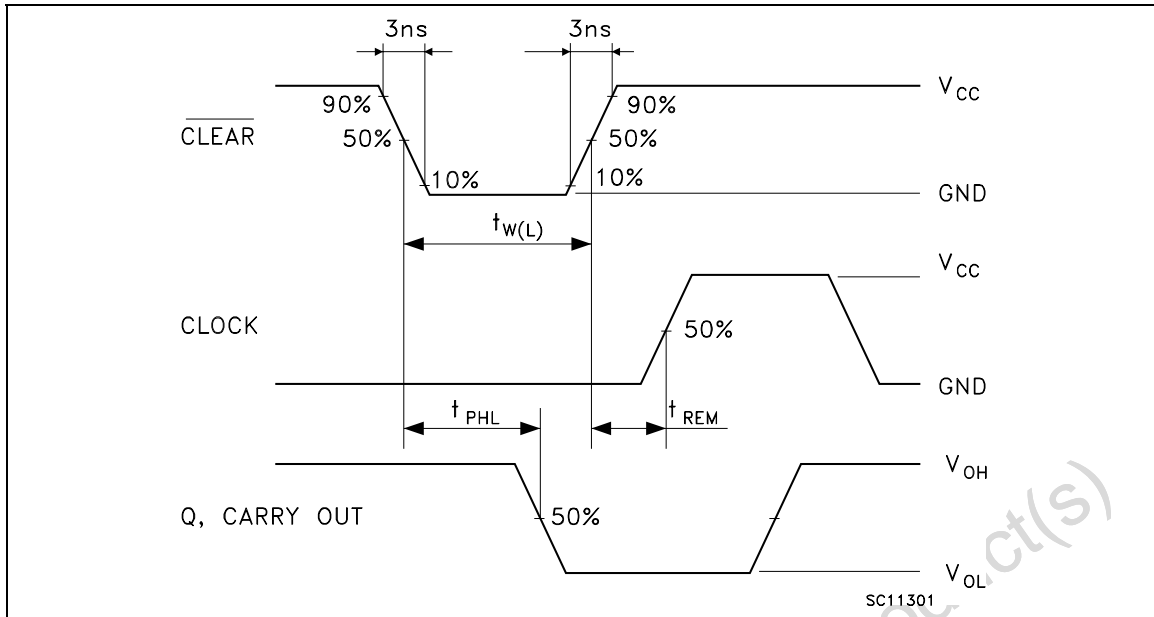

WAVEFORM 3: PROPAGATION DELAYS PRESET MODE (f=1MHz; 50% duty cycle)

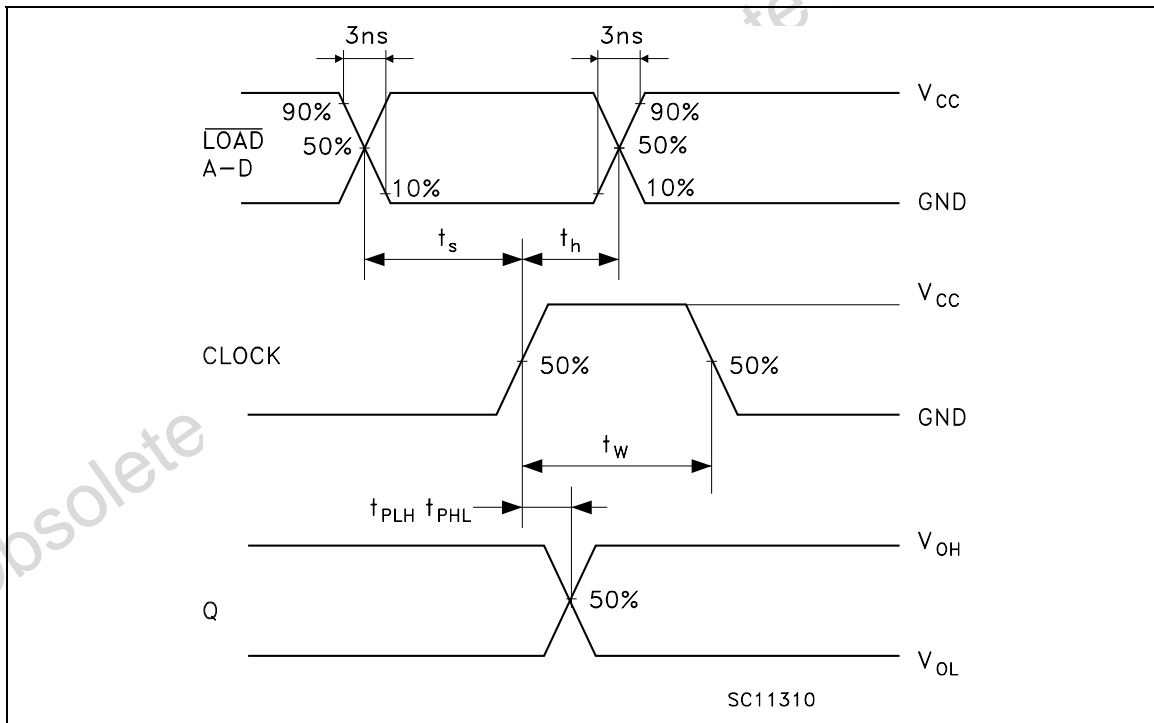

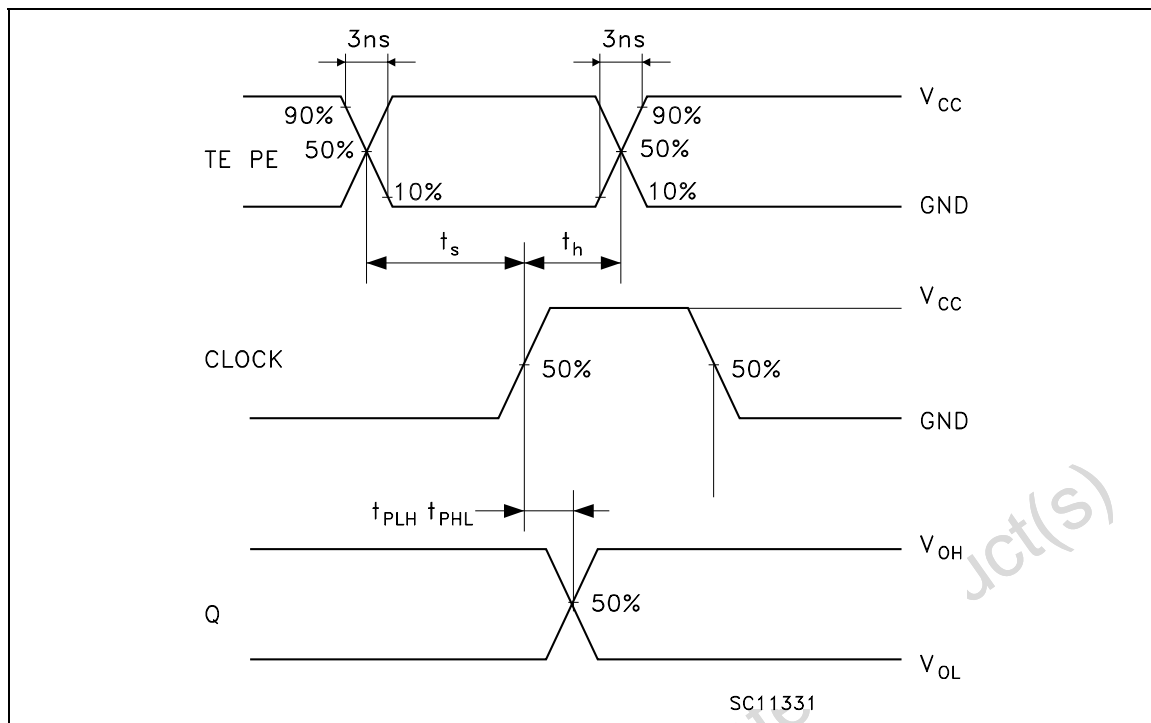
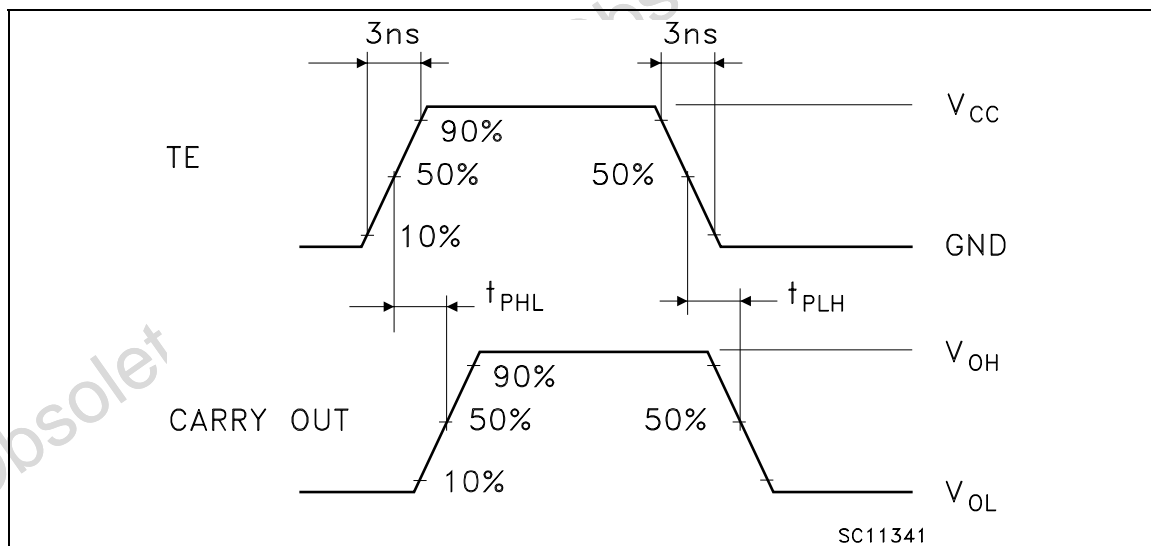
WAVEFORM 4: PROPAGATION DELAYS COUNTABLE MODE ($f=1\text{MHz}$; 50% duty cycle)**WAVEFORM 5: PROPAGATION DELAYS CASCADE MODE** ($f=1\text{MHz}$; 50% duty cycle)

Plastic DIP-16 (0.25) MECHANICAL DATA

DIM.	mm.			inch		
	MIN.	TYP	MAX.	MIN.	TYP.	MAX.
a1	0.51			0.020		
B	0.77		1.65	0.030		0.065
b		0.5			0.020	
b1		0.25			0.010	
D			20			0.787
E		8.5			0.335	
e		2.54			0.100	
e3		17.78			0.700	
F			7.1			0.280
I			5.1			0.201
L		3.3			0.130	
Z			1.27			0.050

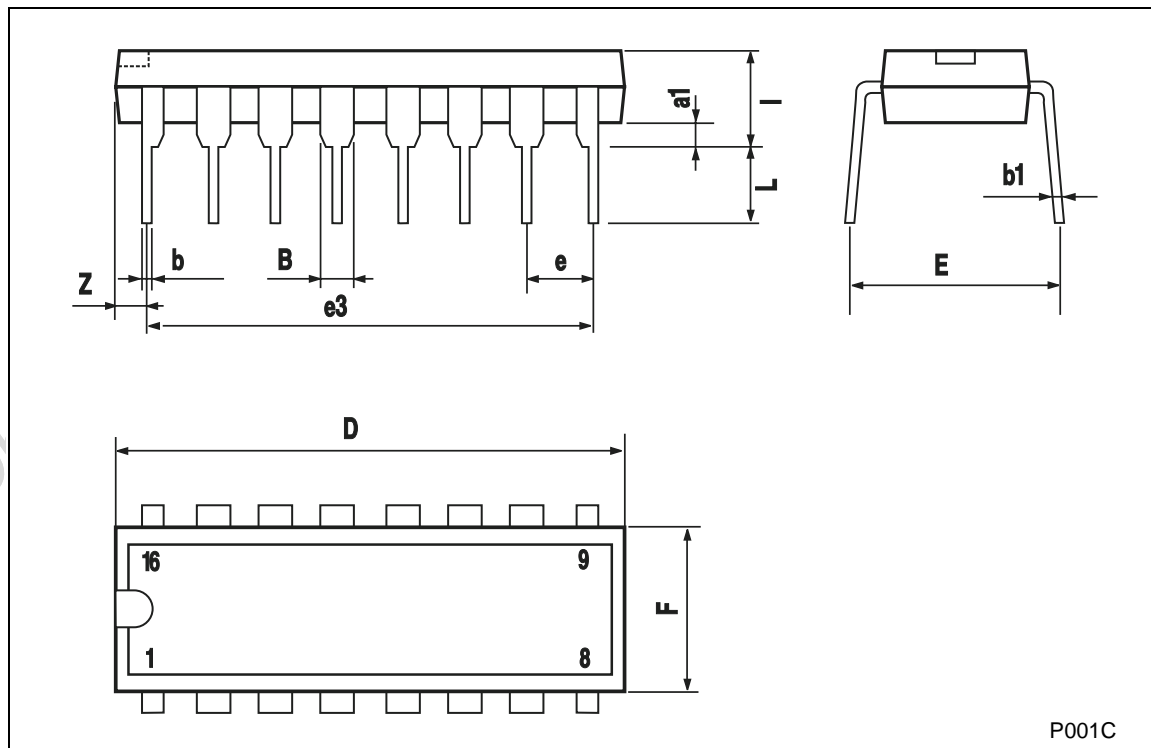

P001C

SO-16 MECHANICAL DATA

DIM.	mm.			inch		
	MIN.	TYP	MAX.	MIN.	TYP.	MAX.
A			1.75			0.068
a1	0.1		0.2	0.003		0.007
a2			1.65			0.064
b	0.35		0.46	0.013		0.018
b1	0.19		0.25	0.007		0.010
C		0.5			0.019	
c1	45° (typ.)					
D	9.8		10	0.385		0.393
E	5.8		6.2	0.228		0.244
e		1.27			0.050	
e3		8.89			0.350	
F	3.8		4.0	0.149		0.157
G	4.6		5.3	0.181		0.208
L	0.5		1.27	0.019		0.050
M			0.62			0.024
S	8° (max.)					

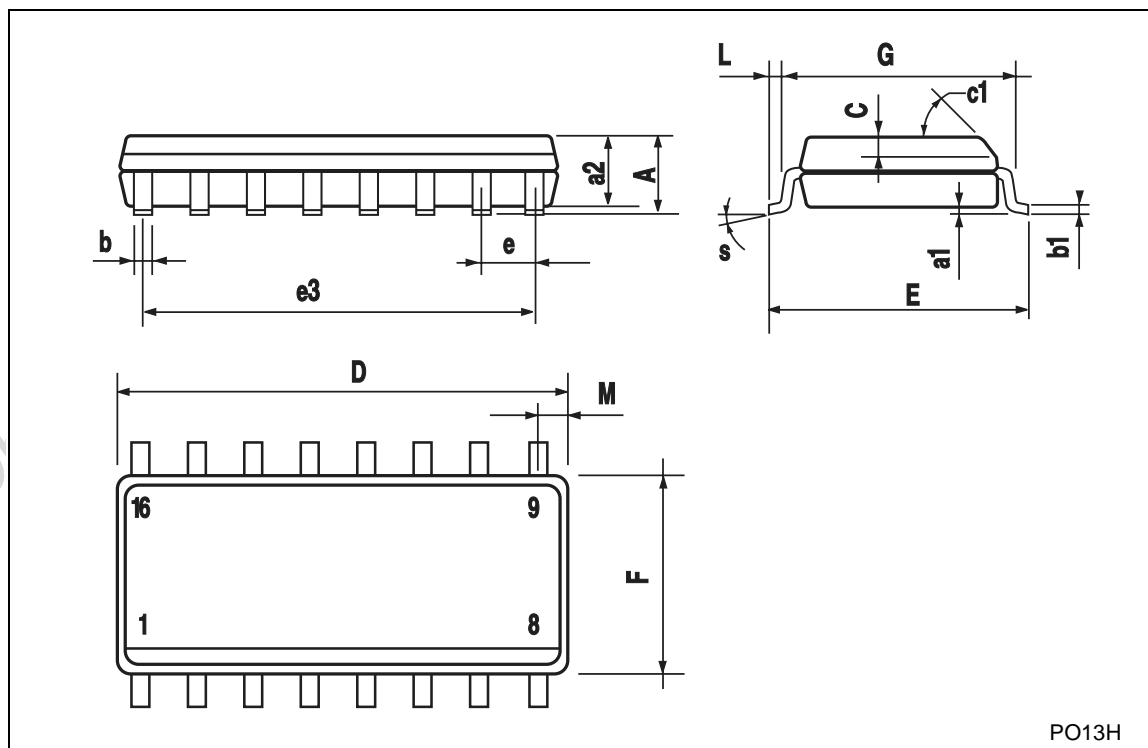

TSSOP16 MECHANICAL DATA

DIM.	mm.			inch		
	MIN.	TYP	MAX.	MIN.	TYP.	MAX.
A			1.2			0.047
A1	0.05		0.15	0.002	0.004	0.006
A2	0.8	1	1.05	0.031	0.039	0.041
b	0.19		0.30	0.007		0.012
c	0.09		0.20	0.004		0.0089
D	4.9	5	5.1	0.193	0.197	0.201
E	6.2	6.4	6.6	0.244	0.252	0.260
E1	4.3	4.4	4.48	0.169	0.173	0.176
e		0.65 BSC			0.0256 BSC	
K	0°		8°	0°		8°
L	0.45	0.60	0.75	0.018	0.024	0.030

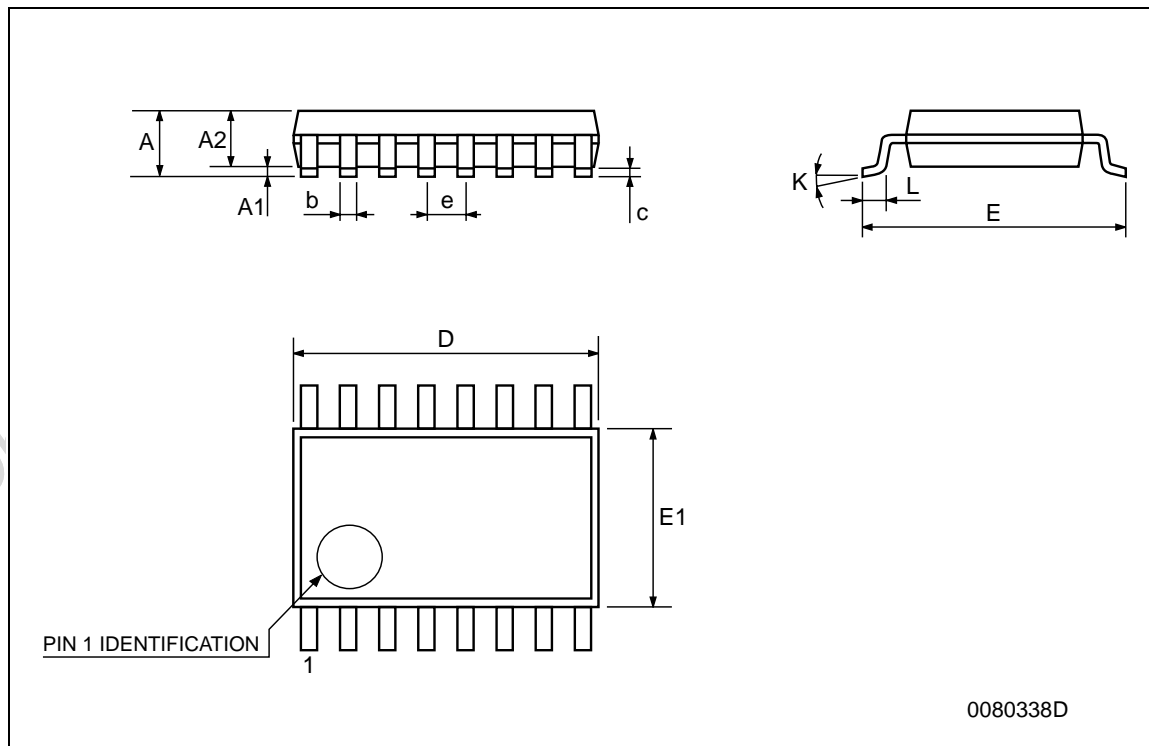

Obsolete Product(s) - Obsolete Product(s)

Information furnished is believed to be accurate and reliable. However, STMicroelectronics assumes no responsibility for the consequences of use of such information nor for any infringement of patents or other rights of third parties which may result from its use. No license is granted by implication or otherwise under any patent or patent rights of STMicroelectronics. Specifications mentioned in this publication are subject to change without notice. This publication supersedes and replaces all information previously supplied. STMicroelectronics products are not authorized for use as critical components in life support devices or systems without express written approval of STMicroelectronics.

© The ST logo is a registered trademark of STMicroelectronics

© 2001 STMicroelectronics - Printed in Italy - All Rights Reserved
STMicroelectronics GROUP OF COMPANIES

Australia - Brazil - China - Finland - France - Germany - Hong Kong - India - Italy - Japan - Malaysia - Malta - Morocco
Singapore - Spain - Sweden - Switzerland - United Kingdom

© <http://www.st.com>

