

Ceramic High Voltage Disc Capacitors, Class 2

DESIGN:

Disc capacitor with epoxy coating

RATED VOLTAGE U_R :

HAZ, HAE, HAX	1kV _{DC}
HBZ, HBE, HBX	2kV _{DC}
HCZ, HCE, HCX	3kV _{DC}
HDE	4kV _{DC}
HEE	5kV _{DC}
HFZ, HFE	6kV _{DC}
HGZ	8kV _{DC}
HHZ	10kV _{DC}
HIZ	15kV _{DC}

DIELECTRIC STRENGTH BETWEEN LEADS:

Component test

HAZ, HAE, HAX	1750V _{DC} , 2s
HBZ, HBE, HBX	3000V _{DC} , 2s
HCZ, HCE, HCX	5000V _{DC} , 2s
HDE	6000V _{DC} , 2s
HEE	7500V _{DC} , 2s
HFZ, HFE	9000V _{DC} , 2s
HGZ	12000V _{DC} , 2s
HHZ	15000V _{DC} , 2s
HIZ	22500V _{DC} , 2s

DISSIPATION FACTOR $\tan \delta$:

HA., HB., HC., HD., HE	$\leq 25 \cdot 10^{-3}$
HF., HG., HH., HI.	$\leq 20 \cdot 10^{-3}$

INSULATION RESISTANCE R_{IS} :

$\geq 1 \cdot 10^{10} \Omega$

CATEGORY TEMPERATURE RANGE θ_A :

(- 40 to + 85 °C)

CLIMATIC CATEGORY ACC. TO EN 60068-1:

40 / 085 / 21

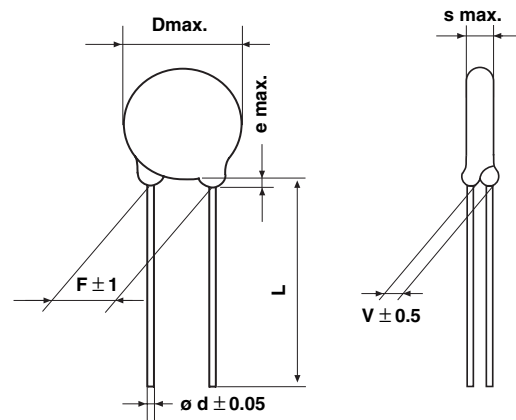

• Dimensions in mm

	Coating Extension e	Standard Lead Length L
HA., HB., HC.	3 max.	30 - 3
HD., HE., HF.,		or
HGZ, HHZ, HIZ	5 max.	10 ± 1

COATING:

Epoxy dipped, insulating,
Flame retarding acc. to UL 94V-0

TEMPERATURE CHARACTERISTIC OF CAPACITANCE:

See General Information

TAPING AND SPECIAL LEAD CONFIGURATIONS:

See General Information

MARKING:

Capacitance value	- Clear text
Capacitance tolerance	- Where $D \geq 9\text{mm}$ only
Rated voltage	- Clear text
Ceramic dielectric	- With Letter code
Manufacturers logo	- Where $D \geq 13\text{mm}$ only

ORDERING INFORMATION

HIZ	101	M	BJ	EJ0	K
MODEL	CAPACITANCE VALUE	TOLERANCE	RATED VOLTAGE	LEAD CONFIGURATION	INTERNAL CODE



		CERAMIC DIELECTRIC: K 2000 CERAMIC CODE: Z CAPACITANCE TOLERANCE: ±10%, ±20%			CERAMIC DIELECTRIC: K 6000 CERAMIC CODE: E CAPACITANCE TOLERANCE: ±20%			CERAMIC DIELECTRIC: K 10000 CERAMIC CODE: X CAPACITANCE TOLERANCE: +50 -20%, (±20%)**														
		RATED VOLTAGE = 1kV _{DC}			RATED VOLTAGE = 1kV _{DC}			RATED VOLTAGE = 1kV _{DC}														
CAP. VALUE (pF)	D x s (MAX) (mm)	F ± 1* (mm)	d ± 0.05* (mm)	V ± 0.5* (mm)	ORDERING CODE	D x s (MAX) (mm)	F ± 1* (mm)	d ± 0.05* (mm)	V ± 0.5* (mm)	ORDERING CODE	D x s (MAX) (mm)	F ± 1* (mm)	d ± 0.05* (mm)	V ± 0.5* (mm)	ORDERING CODE							
47	7 x 3	5	0.6	1.2	HAZ470□BA□□□K																	
56	7 x 3				HAZ560□BA□□□K																	
68	7 x 3				HAZ680□BA□□□K																	
82	7 x 3				HAZ820□BA□□□K																	
100	7 x 3				HAZ101□BA□□□K																	
150	7 x 3				HAZ151□BA□□□K																	
220	7 x 3				HAZ221□BA□□□K																	
330	7 x 3				HAZ331□BA□□□K																	
470	7 x 3				HAZ471□BA□□□K																	
680	7 x 3				HAZ681□BA□□□K																	
1000	9 x 3				HAZ102□BA□□□K											7 x 3	5	0.6	1.2	HAE102MBA□□□K		
1500	9 x 3				HAZ152□BA□□□K											9 x 3				HAE152MBA□□□K		
2200	11 x 3				HAZ222□BA□□□K											9 x 3	HAE222MBA□□□K	7 x 3	5	0.6	1.2	HAX222SBA□□□K
3300	13 x 3				HAZ332□BA□□□K											11 x 3	HAE332MBA□□□K	9 x 3				HAX332SBA□□□K
4700	15 x 3	HAZ472□BA□□□K	11 x 3	HAE472MBA□□□K	9 x 3	HAX472SBA□□□K																
6800																						
0.010μF						13 x 3	7.5				13 x 3	7.5	0.6	1.2	HAX682SBA□□□K							
0.015μF						15 x 3				13 x 3	HAX103SBA□□□K											
0.022μF										17 x 3	HAX153SBA□□□K											
										18 x 3	HAX223SBA□□□K											
		RATED VOLTAGE = 2kV _{DC}			RATED VOLTAGE = 2kV _{DC}			RATED VOLTAGE = 2kV _{DC}														
56	7 x 3	7.5	0.6	1.4	HBZ560□BB□□□K																	
68	7 x 3				HBZ680□BB□□□K																	
82	7 x 3				HBZ820□BB□□□K																	
100	7 x 3				HBZ101□BB□□□K																	
150	7 x 3				HBZ151□BB□□□K																	
220	7 x 3				HBZ221□BB□□□K																	
330	7 x 3				HBZ331□BB□□□K																	
470	7 x 3				HBZ471□BB□□□K																	
680	9 x 3				HBZ681□BB□□□K											7 x 3	7.5	0.6	1.4	HBE681MBB□□□K		
1000	9 x 3				HBZ102□BB□□□K											7 x 3				HBE102MBB□□□K		
1500	11 x 3				HBZ152□BB□□□K											9 x 3	HBE152MBB□□□K	7 x 3	7.5	0.6	1.2	HBX152SBB□□□K
2200	13 x 3				HBZ222□BB□□□K											9 x 3	HBE222MBB□□□K	9 x 3				HBX222SBB□□□K
3300	15 x 3				HBZ332□BB□□□K											11 x 3	HBE332MBB□□□K	9 x 3				HBX332SBB□□□K
4700	17 x 3				HBZ472□BB□□□K											13 x 3	HBE472MBB□□□K	11 x 3				HBX472SBB□□□K
6800						11 x 3	HBE682MBB□□□K	11 x 3	HBX682SBB□□□K													
0.01μF						15 x 3	HBE103MBB□□□K	15 x 3	HBX103SBB□□□K													
0.015μF											17 x 3				HBX153SBB□□□K							
0.022μF											20 x 3				HBX223SBB□□□K							

* Standard lead configuration, other lead spacing and diameter available on request

** ± 20% available on request

CERAMIC DIELECTRIC: K 2000 CERAMIC CODE: Z CAPACITANCE TOLERANCE: ± 10%, ± 20%				CERAMIC DIELECTRIC: K 6000 CERAMIC CODE: E CAPACITANCE TOLERANCE: ± 20%				CERAMIC DIELECTRIC: K 10000 CERAMIC CODE: X CAPACITANCE TOLERANCE: + 50 - 20%, (± 20 %) **									
RATED VOLTAGE = 3kV _{DC}				RATED VOLTAGE = 3kV _{DC}				RATED VOLTAGE = 3kV _{DC}									
CAP. VALUE (pF)	D x s (MAX) (mm)	F ± 1* (mm)	d ± 0.05* (mm)	V ± 0.5* (mm)	ORDERING CODE	D x s (MAX) (mm)	F ± 1* (mm)	d ± 0.05* (mm)	V ± 0.5* (mm)	ORDERING CODE	D x s (MAX) (mm)	F ± 1* (mm)	d ± 0.05* (mm)	V ± 0.5* (mm)	ORDERING CODE		
68	7 x 4	10	0.6	1.8	HCZ680□BC□□□K	7 x 4	10	0.6	2	HCE471MBC□□□K	7 x 4	10	0.6	1.8	HCX681SBC□□□K		
82	7 x 4				HCZ820□BC□□□K											HCE681MBC□□□K	HCX102SBC□□□K
100	7 x 4				HCZ101□BC□□□K											HCE102MBC□□□K	
120	7 x 4				HCZ121□BC□□□K												
150	7 x 4				HCZ151□BC□□□K												
180	8 x 4				HCZ181□BC□□□K												
220	8 x 4				HCZ221□BC□□□K												
330	8 x 4				HCZ331□BC□□□K												
470	10 x 4				HCZ471□BC□□□K												
680	10 x 4				HCZ681□BC□□□K												
1000	11 x 4	HCZ102□BC□□□K			9 x 4	10	0.6	2	HCE102MBC□□□K	7 x 4	10	0.6	1.8	HCX102SBC□□□K			
1200	15 x 4	HCZ122□BC□□□K			11 x 4	10	0.8	2.2	HCE152MBC□□□K	8 x 4	10	0.6	1.8	HCX152SBC□□□K			
1500	15 x 4	HCZ152□BC□□□K			11 x 4	10	0.8	2.2	HCE222MBC□□□K	9 x 4	10	0.6	1.8	HCX222SBC□□□K			
2200	17 x 4	HCZ222□BC□□□K			15 x 4	10	0.8	2.2	HCE332MBC□□□K	10 x 4	10	0.6	1.8	HCX332SBC□□□K			
3300	21 x 4	HCZ332□BC□□□K			17 x 4	10	0.8	2.2	HCE472MBC□□□K	11 x 4	10	0.6	1.8	HCX472SBC□□□K			
4700	21 x 4	HCZ472□BC□□□K			21 x 4	10	0.8	2.2	HCE682SBC□□□K	15 x 4	10	0.6	1.8	HCX682SBC□□□K			
6800	25 x 4	HCZ682□BC□□□K			25 x 4	10	0.8	2.5	HCE103MBC□□□K	17 x 4	10	0.8	2	HCX103SBC□□□K			
0.01µF											21 x 4	10	0.8	2	HCX153SBC□□□K		
0.015µF																	

CERAMIC DIELECTRIC: K 6000 CERAMIC CODE: E CAPACITANCE TOLERANCE: ± 20%, (± 10%) **				CERAMIC DIELECTRIC: K 6000 CERAMIC CODE: E CAPACITANCE TOLERANCE: ± 20%								
RATED VOLTAGE = 4kV _{DC}				RATED VOLTAGE = 5kV _{DC}								
CAP. VALUE (pF)	D x s (MAX) (mm)	F ± 1* (mm)	d ± 0.05* (mm)	V ± 0.5* (mm)	ORDERING CODE	D x s (MAX) (mm)	F ± 1* (mm)	d ± 0.05* (mm)	V ± 0.5* (mm)	ORDERING CODE		
33	8 x 4.5	12.5	0.6	1.9	HDE330MBD□□□K	7 x 5.0	12.5	0.6	3.8	HEE221MBE□□□K		
47	8 x 5.0				HDE470MBD□□□K						HEE331MBE□□□K	
68	8 x 5.0				HDE680MBD□□□K							
100	8 x 5.0				HDE101MBD□□□K							
150	8 x 5.0				HDE151MBD□□□K							
220	8 x 5.0				HDE221MBD□□□K							
330	8 x 5.0				HDE331MBD□□□K							
470	8 x 5.0				HDE471MBD□□□K							
680	9 x 5.0				HDE681MBD□□□K							
1000	10 x 5.0				HDE102MBD□□□K							
1500	12 x 5.0	HDE152MBD□□□K			11 x 5.0	12.5	0.8	3.8	HEE102MBE□□□K			
2200	13 x 5.0	HDE222MBD□□□K			13 x 5.5	12.5	0.8	3.8	HEE152MBE□□□K			
3300	15 x 5.0	HDE332MBD□□□K			15 x 5.5	12.5	0.8	3.8	HEE222MBE□□□K			
4700	18 x 5.0	HDE472MBD□□□K										

*Standard lead configuration, other lead spacing and diameter available on request

**Narrow tolerance available on request



CAP. VALUE (pF)	CERAMIC DIELECTRIC: K 2000 CERAMIC CODE: Z CAPACITANCE TOLERANCE: ±20%, (±10%)				CERAMIC DIELECTRIC: K 6000 CERAMIC CODE: E CAPACITANCE TOLERANCE: ± 20%				CERAMIC DIELECTRIC : K 2000 CERAMIC CODE : X CAPACITANCE TOLERANCE: ± 20% (± 10%)						
	RATED VOLTAGE = 6kV _{DC}				RATED VOLTAGE = 6kV _{DC}				RATED VOLTAGE = 8kV _{DC}						
	D x s (MAX) (mm)	F ±1* (mm)	d ±0.05* (mm)	V ±0.5* (mm)	ORDERING CODE	D x s (MAX) (mm)	F ±1* (mm)	d ±0.05* (mm)	V ±0.5* (mm)	ORDERING CODE	D x s (MAX) (mm)	F ±1* (mm)	d ±0.05* (mm)	V ±0.5* (mm)	ORDERING CODE
56	7 x 5				HFZ560□BF□□□K										
68	7 x 5				HFZ680□BF□□□K										
82	7 x 5				HFZ820□BF□□□K										
100	8 x 5				HFZ101□BF□□□K										
120	8 x 5				HFZ121□BF□□□K						9x8.3				HGZ101MBP□□□K
150	8 x 5				HFZ151□BF□□□K	7x5				HFE151MBF□□□K	9x8.3				HGZ121MBP□□□K
180	10 x 5		0.6		HFZ181□BF□□□K						11x8.3				HGZ151MBP□□□K
220	10 x 5				HFZ221□BF□□□K	7x5				HFE221MBF□□□K	11x8.3				HGZ181MBP□□□K
270	10 x 5				HFZ271□BF□□□K						11x8.3				HGZ221MBP□□□K
330	10 x 5				HFZ331□BF□□□K	9x5				HFE 331MBF□□□K	13x8.3				HGZ271MBP□□□K
390	12 x 5	12.5		3.5	HFZ391□BF□□□K						13x8.3				HGZ331MBP□□□K
470	12 x 5				HFZ471□BF□□□K	9x5				HFE471MBF□□□K	14x8.3	12.5	0.8	4	HGZ391MBP□□□K
560	13 x 5				HFZ561□BF□□□K						16x8.3				HGZ471MBP□□□K
680	15 x 5				HFZ681□BF□□□K	9x5	12.5	0.6	3.5	HFE681MBF□□□K	16x8.3				HGZ561MBP□□□K
820	15 x 5				HFZ821□BF□□□K						18x8.3				HGZ681MBP□□□K
1000	17 x 5				HFZ102□BF□□□K	11x5.5				HFE102MBF□□□K	18x8.3				HGZ821MBP□□□K
1200	19 x 5				HFZ122□BF□□□K						21x8.3				HGZ102MBP□□□K
1500	21 x 5		0.8		HFZ152□BF□□□K	13x5.5				HFE152MBF□□□K	21x8.3				HGZ122MBP□□□K
1800	21 x 5				HFZ182□BF□□□K						24x8.3				HGZ152MBP□□□K
2200	25 x 5				HFZ222□BF□□□K	15x5.5				HFE222MBF□□□K	24x8.3				HGZ182MBP□□□K
2700	25 x 5				HFZ272□BF□□□K										HGZ222MBP□□□K
3300						21x5.5				HFE332MBF□□□K					
4700						21x5.5			0.8	HFE472MBF□□□K					
6800						23x5.5				HFE682MBF□□□K					

CAP. VALUE (pF)	CERAMIC DIELECTRIC: K 2000 CERAMIC CODE: Z CAPACITANCE TOLERANCE: ± 20%, (± 10%)				CERAMIC DIELECTRIC: K 2000 CERAMIC CODE: Z CAPACITANCE TOLERANCE: ± 20%, (± 10%)					
	RATED VOLTAGE = 10kV _{DC}				RATED VOLTAGE = 15kV _{DC}					
	D x s (MAX) (mm)	F ±1* (mm)	d ±0.05* (mm)	V ±0.5* (mm)	ORDERING CODE	D x s (MAX) (mm)	F ±1* (mm)	d ±0.05* (mm)	V ±0.5* (mm)	ORDERING CODE
100	11 x 6				HHZ101MBH□□□K	18 x 8				HIZ101MBJ□□□K
120	11 x 6				HHZ121MBH□□□K	18 x 8			4	HIZ121MBJ□□□K
150	11 x 9				HHZ151MBH□□□K	12 x 11				HIZ151MBJ□□□K
180	11 x 9				HHZ181MBH□□□K	13 x 11				HIZ181MBJ□□□K
220	11 x 9				HHZ221MBH□□□K	13 x 11				HIZ221MBJ□□□K
270	13 x 9				HHZ271MBH□□□K	14 x 11	12.5	0.8	7	HIZ271MBJ□□□K
330	13 x 9				HHZ331MBH□□□K	15 x 11				HIZ331MBJ□□□K
390	14 x 9	12.5	0.8	5	HHZ391MBH□□□K	16 x 11				HIZ391MBJ□□□K
470	16 x 9				HHZ471MBH□□□K	18 x 11				HIZ471MBJ□□□K
560	16 x 9				HHZ561MBH□□□K	21 x 11				HIZ561MBJ□□□K
680	18 x 9				HHZ681MBH□□□K	21 x 11				HIZ681MBJ□□□K
820	18 x 9				HHZ821MBH□□□K	21 x 11				HIZ821MBJ□□□K
1000	21 x 9				HHZ102MBH□□□K					
1200	21 x 5				HHZ122MBH□□□K					

NOT FOR NEW DESIGNS
REPLACEMENT
HIK... SERIES

*Standard lead configuration, other lead spacing and diameter available on request

ORDERING CODE			
Ordering code	□ 7th digit	Capacitance tolerance	± 10% = K ± 20% = M
	□□□ 10th / 11th / 12th digit	Lead configuration (See General Info.)	+ 50 - 20% = S



Notice

Specifications of the products displayed herein are subject to change without notice. Vishay Intertechnology, Inc., or anyone on its behalf, assumes no responsibility or liability for any errors or inaccuracies.

Information contained herein is intended to provide a product description only. No license, express or implied, by estoppel or otherwise, to any intellectual property rights is granted by this document. Except as provided in Vishay's terms and conditions of sale for such products, Vishay assumes no liability whatsoever, and disclaims any express or implied warranty, relating to sale and/or use of Vishay products including liability or warranties relating to fitness for a particular purpose, merchantability, or infringement of any patent, copyright, or other intellectual property right.

The products shown herein are not designed for use in medical, life-saving, or life-sustaining applications. Customers using or selling these products for use in such applications do so at their own risk and agree to fully indemnify Vishay for any damages resulting from such improper use or sale.