

# Agilent FieldFox RF Vector Network Analyzer

## N923A 4/6 GHz

### Technical Overview



*World's most accurate handheld vector network analyzer*



**Agilent Technologies**

# World's Most Accurate Handheld Vector Network Analyzer



## FieldFox

The first step in ensuring that wireless communication systems are running at their optimum level is to verify that RF components in the system, such as cables, antennas, and filters are properly tested and kept in good condition. The majority of these tests are conducted in the field or in a warehouse, where bench top instruments are not readily available, testing space is limited, or where a power source is simply not available. Agilent's handheld FieldFox RF Vector Network Analyzer (VNA) is designed to make network analysis measurements in the field easier, convenient, and the most reliable.

### *QuickCal* revolutionizes calibration in the field

The number one challenge in making accurate network analyzer measurements in the field is reliability, where large temperature fluctuations are common. Agilent's FieldFox RF VNA is the only handheld network analyzer with *QuickCal* technology that allows operators to easily correct for drift errors caused by temperature changes. *QuickCal* is a built-in calibration system that provides worry-free accuracy and reliability. FieldFox's built-in standards make calibration simpler, by eliminating the need to carry mechanical calibration kits into the field.

### Unmatched reliability for day-to-day tests

Whether you are testing a flight line for the air force, an RF system on a war ship, a wireless communication cable and antenna system, tuning RF components, or making other general purpose network analyzer measurements — the FieldFox RF VNA provides unmatched measurement reliability, stability, and efficiency for your every day test needs. The FieldFox RF VNA also builds on Agilent's 40-year legacy of network analysis leadership in calibration, accuracy, and innovation.



# FieldFox



## Key measurements

- Full 2-port error corrected S-parameters, magnitude and phase
- Cable and antenna test (distance-to-fault, return loss, and VSWR)
- Cable loss measurement (1-port)
- Insertion loss and transmission measurement (2-port)
- Magnitude, phase, Smith chart, polar display, group delay and more
- Vector voltmeter (1- and 2- channel)
- Power meter with external USB power sensor

## Key differentiators

- Built-in *QuickCal* enables calibration without a cal kit
- Best measurement stability over time and temperature
- Industry's only handheld network analyzer with MIL PRF 28800F Class 2 compliance with no exceptions
- Superior system dynamic range of 100 dB
- Easy-to-use, task-driven user interface
- Weather resistant, compact, and field-friendly design, no fan and vents

Easy to use in the field

# FieldFox

7.4" W  
188 mm

11.5" H  
292 mm

Connector covers help keep dust out

Anti-glare 6.5 inch LCD display with LED backlight

Convenient side strap makes it easy to hold and carry

Task-driven keys are grouped to easily and naturally perform standard field measurements

Portrait design and large buttons for easy operation — even with gloves on

Dedicated marker keys for quick marker function access

Backlit keypad

Navigate between four traces using up/down arrows



# FieldFox



Test Port 1

External reference and external trigger

Test Port 2

Connector bay protects RF connectors

Spacious connector design makes connections fast and simple

Quick-connect shoulder strap clips



Easily accessible battery compartment

LAN port for remote control using SCPI and fast data transfer

Micro SD flash card slot for additional data storage

Headphone jack

Gasketed doors protect ports from moisture

USB ports for convenient data transfer and GPS receiver





## Vector Network Analysis

The base FieldFox RF VNA provides transmission/reflection (T/R) measurements, or S11 and S21, with magnitude and phase.

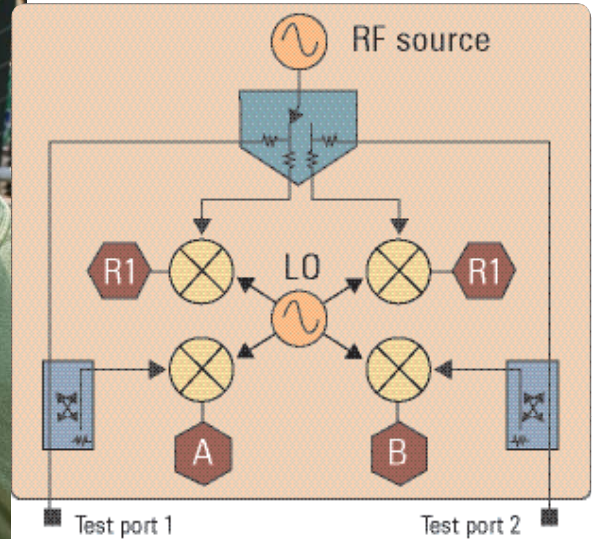

Adding Option 122 (full 2-port S-parameters) brings new levels of accuracy and convenience for testing RF components. A full 2-port network analyzer lets you measure the forward and reverse characteristics of your components without having to disconnect, turn around, and reconnect them to the analyzer.

It also provides full 2-port calibration to give you the best measurement accuracy possible. Depending upon your application, you can choose the optimum performance level of an S-parameter analyzer (Option 122) or transmission reflection analyzer (base model).

You also can simultaneously measure and view all four S-parameters, with a single connection.

FieldFox VNA contains four independent, sensitive receivers. The receivers provide more than 100 dB of dynamic range for vector measurements of high rejection, narrowband devices such RF filters. The receivers also make possible full 2-port error correction with the Unknown Thru method, allowing you to measure non-insertable devices.



Smith chart display

Make multiple measurements simultaneously

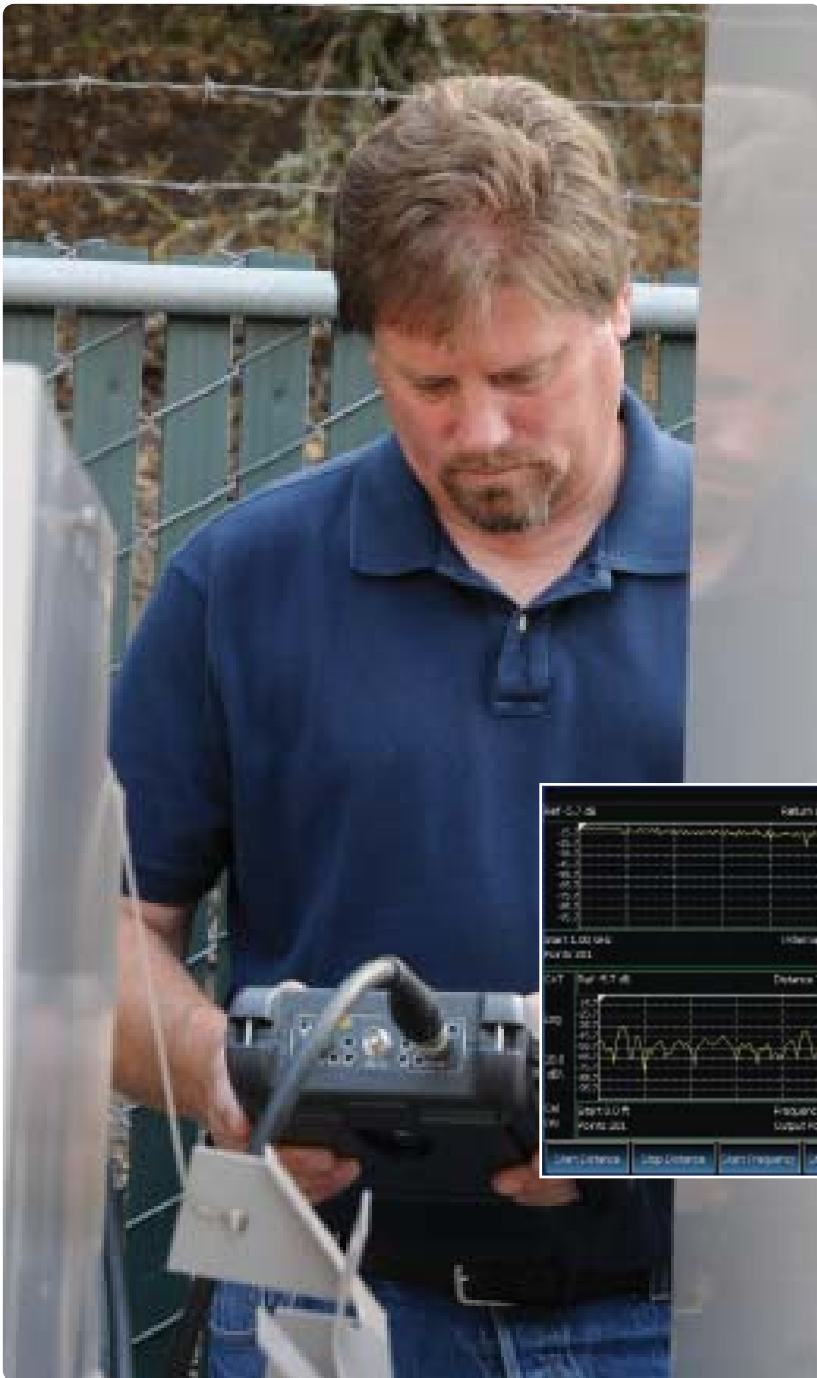

## Cable and antenna analyzer

Fifty to sixty percent of cell site problems are caused by faulty cables, connectors, and antennas. Degraded feed lines cause poor coverage, unnecessary handovers, paging failures and access failures on the uplink. To avoid service quality problems, it is critical to keep the cell sites' cable and antenna systems in good condition.

Use FieldFox to make return loss, VSWR, insertion loss/transmission, one-port cable loss, and distance to fault (DTF) measurements. You can test antennas, cables, filters, and amplifiers with a single handheld instrument.

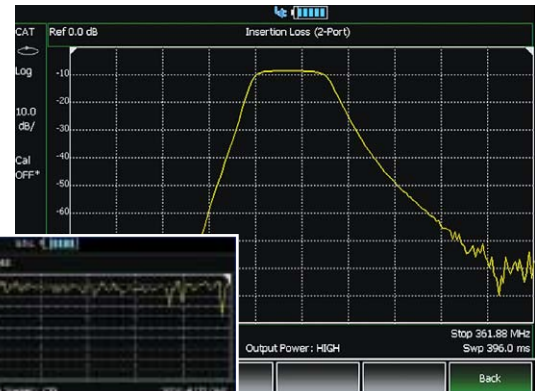

Insertion loss display

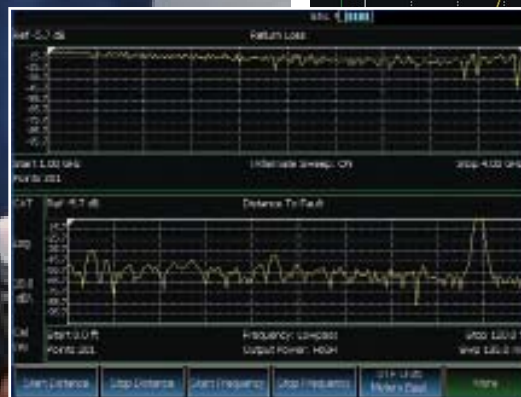

Return loss and DTF dual display

## Return loss and DTF measurements

FieldFox can make return loss and distance-to-fault measurements at the same time. It helps you correlate overall system degradation with specific faults in the cable and antenna system.

The built-in cable editor allows you to edit existing cable types on-site, and save them as new cable types with user defined names.

# FieldFox

## **CalReady** when the instrument is turned on

Save time and get right to work with FieldFox's CalReady feature, which makes the unit calibration ready at either test port immediately following power on or preset. FieldFox is already calibrated and ready to make accurate measurements such as S11, S22, 1-port cable loss, VSWR, return loss, and DTF measurements at the test port without having to connect/disconnect additional cables or calibration devices.

## **Industry's first and only QuickCal**

FieldFox is the industry's first and only handheld network analyzer with a built-in calibration capability that allows you to calibrate the network analyzer without carrying a calibration kit into the field. As with any test instrument, when you add an additional device to the test port, such as a jumper cable or adapter, you need to recalibrate using a calibration kit (cal kit). *QuickCal* eliminates the need to carry and use a cal kit, and also provides worry-free accuracy and excellent reliability. *QuickCal* allows the operator to easily correct drift errors caused by temperature changes during instrument operation.

The FieldFox RF VNA's full 2-port *QuickCal* supports measurements such as transmission/reflection, S21, S12, S11, S22, 1-port cable loss, VSWR, return loss, DTF, and gain/insertion loss. Full 2-port QuickCal is based on Agilent's Unknown Thru calibration methodology, providing an accurate way to measure a non-insertable device, such as a female-female filter.

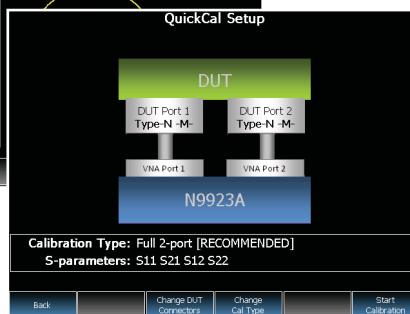
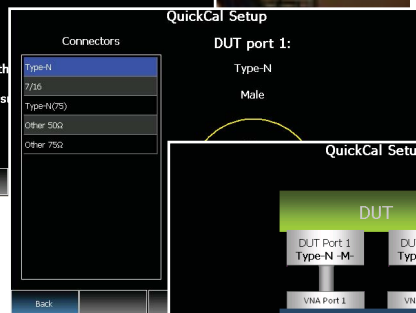
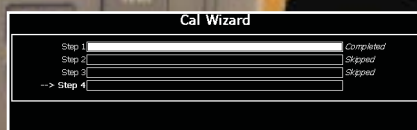
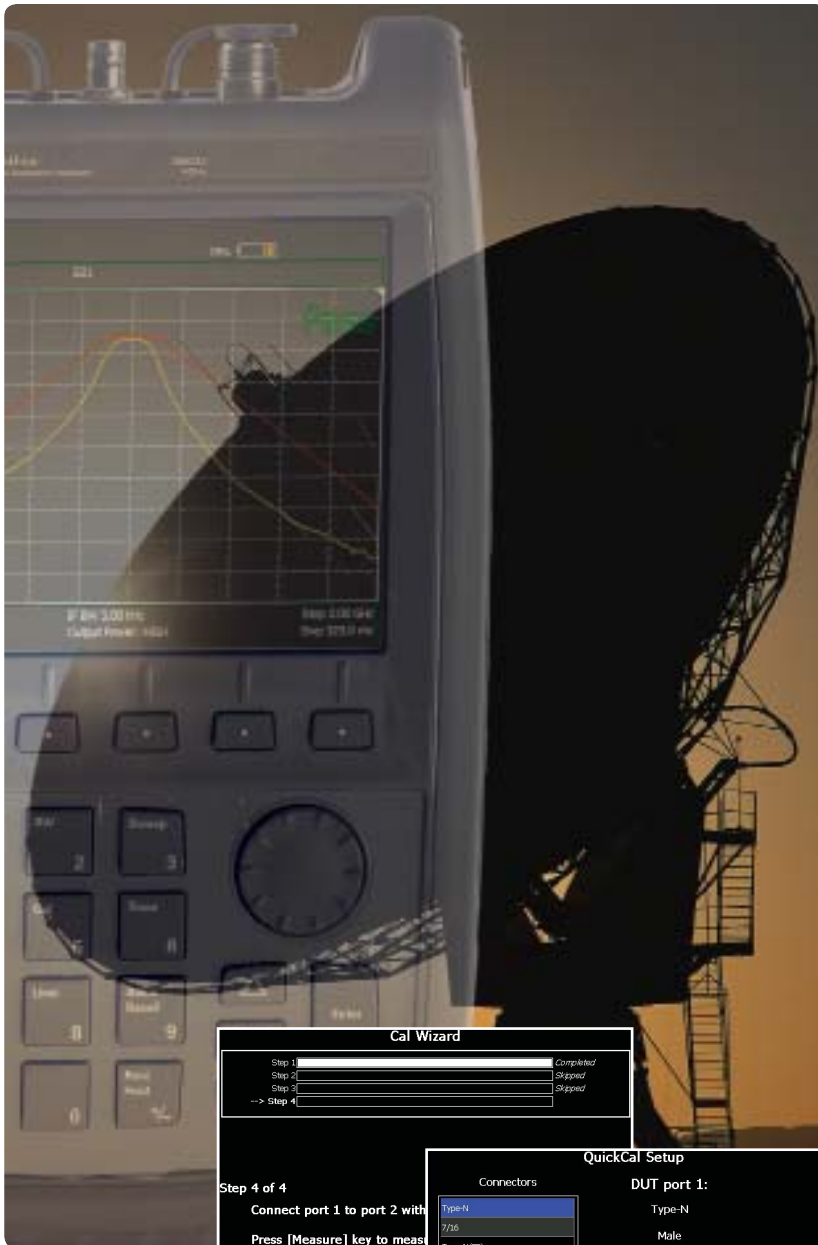

Calibration Wizard



# FieldFox



Power meter display

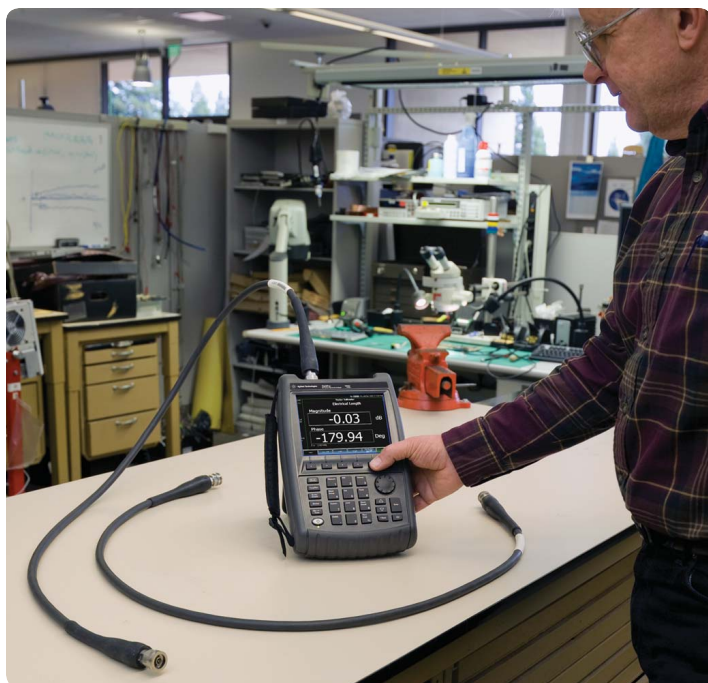

Vector voltmeter used for cable trimming

## Broadband calibration

FieldFox allows you to make broadband calibrations, which means the instrument is calibrated over the maximum frequency range. After a broadband calibration, you can change the frequency range or number of points without recalibrating the instrument. The calibration is interpolated, and accuracy is maintained.

## User calibration kit support

FieldFox supports many Agilent standard calibration kits. In addition to *CalReady* and *QuickCal*, FieldFox also provides a comprehensive calibration utility. To obtain the most accurate measurement, users need to use cal kits that match their device connector types. FieldFox allows users to define their own mechanical calibration kits.

## Power meter

FieldFox can connect with the Agilent U2000 Series USB power sensors to make RF/microwave power measurements up to 24 GHz.

FieldFox provides true average power measurements with a high dynamic range from  $-60$  dBm to  $+44$  dBm (sensor dependent).

The sensor has an internal zeroing function and the sensor does not require external calibration.

## Electrical delay and port extension

For in-fixture measurements, use FieldFox's port extension or electrical delay capability to easily extend the reference plane to the device interface for accurate measurements. You can use the electrical delay capability to measure *deviation from linear phase* by removing the linear portion of the phase delay.



#### VVM applications:

- Cable trimming of phase matched cables
- Verifying the isolation of 2-port components
- Radio navigation – VHF omnidirectional radio range (VOR) and instrumentation landing system (ILS)

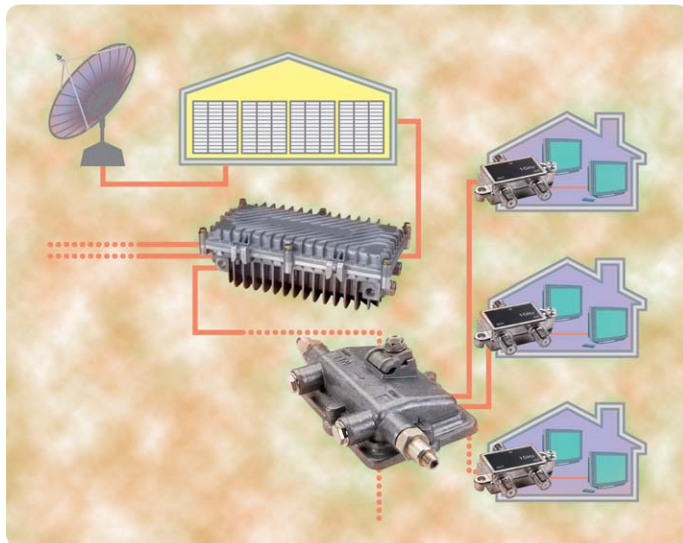

Cable TV distribution system, cable TV is a 75 ohm system

## Vector voltmeter

Using FieldFox's vector voltmeter (VVM), the phase shift and electrical length of a device can be measured.

By utilizing the "zero" function, the phase and electrical length of one device can be measured relative to a "golden device". You can view results on the large display as far as ten feet away. And since every FieldFox is *CalReady*, you don't need to calibrate when VVM measurements are done at the test port.

The VVM option also provides ratio measurements of two receivers or two channels, A/B or B/A. An external signal source is required for this measurement. You can use this capability to verify the magnitude and phase differences between multiple signal paths.

## 75 ohm device test

Most of the components used in cable TV systems are 75 ohm, like cables, filters, splitters and switches. Often the performance of devices, such as the insertion loss or return loss of a filter need to be tested in the field.

You can use the FieldFox RF VNA to measure 75-ohm devices easily, without needing to purchase additional hardware or software options. *QuickCal*, combined with a 50/75 ohm adapter (eg. Agilent part: 1250-0597) at each port and a 75 ohm load, turns the instrument into a 75 ohm tester. Alternatively you can use any of Agilent's 75 ohm calibration kits, along with a pair of 50/75 ohm adapters.





Perform and view return loss and distance to fault measurements at the same time



Tower mounted amplifier (TMA) measurement



Filter and amplifier measurement

## Comprehensive measurement capabilities

<b>Vector network analysis</b>	Provides accurate network analysis of RF components and enables you to measure and display all four S-parameters simultaneously, with a single connection. This means you can quickly and accurately characterize the device under test, using a handheld instrument.
<b>Cable and antenna test</b> <ul style="list-style-type: none"> <li>• Return loss, SWR</li> <li>• Distance-to-fault</li> </ul>	Return loss/SWR measurements allow you to evaluate the impedance matching performance of a feed line across the frequency range of interest.  Distance-to-fault measurements help you identify faults along a feed line. You can use these measurements to precisely pinpoint the location of damaged or degraded antennas, connectors, amplifiers, filters, duplexers, or other components.  FieldFox provides up to a 1001 data-point resolution to help accurately locate faults and extend measurement distance.
<b>Transmission test</b> <ul style="list-style-type: none"> <li>• Cable loss</li> <li>• Insertion loss</li> <li>• Amplifier gain</li> </ul>	Transmission tests are used to accurately measure cable loss, insertion loss (filters) and amplifier gain (tower mounted amplifier). FieldFox offers 2-port transmission magnitude and phase measurements with a typical dynamic range of 100 dB.
<b>One-port cable loss</b>	For already-installed cables, FieldFox accurately measures one-port cable loss. The instrument measures the actual cable loss, without the need for additional computations.
<b>CalReady at test port</b>	Each instrument is calibrated at the test ports. When you power up the instrument, it is ready to make accurate measurements such as S11, S22, one-port cable loss, VSWR, return loss and DTF at the test port.
<b>QuickCal</b>	The industry's first and only built-in calibration system allows you to calibrate the network analyzer without carrying a calibration kit into the field. <b>QuickCal</b> eliminates the hassle of carrying and using a cal kit, plus provides worry-free accuracy and excellent reliability.  <b>QuickCal</b> allows operators to easily correct for drift errors caused by temperature changes during instrument operation. Full 2-port <b>QuickCal</b> is based on Agilent's Unknown Thru calibration methodology. It is an accurate way to measure non insertable devices, such as female-female duplexers.
<b>Mechanical calibration</b>	Open-short-load (OSL) calibration is standard in FieldFox. Common calibration kit constants are preloaded in the instrument. Additional kits can be added by users.



Smith chart display



Easy-to-use save/recall functions



Duplexer measurement

## Comprehensive measurement capabilities *continued*

<b>Interference rejection</b>	The FieldFox RF VNA interference rejection mode is able to make reliable return loss and distance-to-fault measurements of cable and antenna systems under high interference signal environments. It can make valid measurements for interference signals coupled into the system up to +16 dBm.
<b>Power meter</b>	Makes accurate true average power measurements without the need for a power meter. The state-of-the-art Agilent USB power sensors provide measurements up to 24 GHz.
<b>Smith chart</b>	Smith charts can be used to display impedance matching characteristics in cable and antenna systems.
<b>Vector voltmeter</b>	The large vector voltmeter display makes it easy to match two or more device's electric length and ensure signals that travel on different devices have the same delay.
<b>Electrical delay</b>	Using the electrical delay function, you can remove the linear portion of the phase shift and view the deviation from linear phase.
<b>Port extension</b>	Allows you to extend the reference plane after calibration. This feature is useful for measurements such as in-fixture test, where calibrating at the DUT or reference plane is cumbersome.
<b>GPS</b>	Enables operators to find exact locations, and time/location stamp their measurement reports. The GPS information can be displayed on the screen, and saved as part of the image or data file, for reporting purposes.

## Data management

<b>Limit lines</b>	Automated pass/fail testing eliminates the guesswork from your test processes and helps ensure that your components are aligned and tested to the same specifications at all test stations. Pass/fail testing is easily accomplished with user-defined limit lines, which let you quickly and consistently compare measured data to test limits. The pass/fail results are displayed clearly on the instrument screen to minimize operator errors or misinterpretation.
<b>Save/recall states</b>	Save time and reduce operator errors with recall states. You can quickly switch between different manufacturing tests simply by recalling the appropriate instrument state. Saving and recalling states also eliminates operator errors that occur during repeated entry of instrument parameters. Each recall state contains all instrument parameters such as start and stop frequencies, power level, number of trace points, IF bandwidth, calibration data, markers, limit lines, and more.
<b>Powerful marker functions</b>	Speed up component test times by using the power of built-in data markers. Use the six markers per trace to display data in absolute or relative terms.



# FieldFox



Make accurate true average power measurements without bringing along a power meter



Transflective display makes it easy to read measurements in direct sunlight



Water resistant chassis withstands wide temperature ranges and humid environments

## Field-proof usability

<b>Transflective display and backlit keys</b>	The display is designed for easy viewing in indoor and outdoor settings and in direct sunlight and darkness. Access different display modes via softkeys.
<b>Functional key access</b>	Front-panel keys make it easy to perform tasks and make measurements.
<b>One-button measurement</b>	Provides task-driven user interface to simplify the measurements.

## Rugged design

<b>Water-resistant chassis, keypad and case design</b>	The case is made from polycarbonates that withstand wide temperature ranges and salty, humid environments.
<b>RF connector protection</b>	A specially designed connector bay protects the RF connectors from damage during drops or other external impacts.
<b>Dust-free design</b>	With no vents or fans in the case, FieldFox resists dust for better equipment reliability.
<b>Meets tough environmental standard</b>	Industry's only handheld network analyzer with MIL Class 2 compliance with no exceptions.
<b>Gasketed ports</b>	Protects instrument from moisture.

## Modern connectivity

<b>USB 2.0 ports</b>	Two USB 2.0 ports can be used to transfer files.
<b>LAN port</b>	Used for data transfer, remote control, and SCPI programming. Also used with GPS receiver.
<b>SCPI support</b>	SCPI over LAN allows users to automate tests or control a FieldFox from a remote location.
<b>Micro SD flash card slot</b>	Use as a data storage device.
<b>FieldFox Data Link software</b>	Transfer data from the instrument to a PC for back-office applications such as baseline analysis and report generation.

A condensed version of the specifications is provided here. See the User's Guide for the complete version;  
<http://cp.literature.agilent.com/litweb/pdf/N9923-90001.pdf>

### Specification (spec.):

Warranted performance. Specifications include guardbands to account for the expected statistical performance distribution, measurement uncertainties, and changes in performance due to environmental conditions. The following conditions must be met:

- FieldFox has been turned on at least 10 minutes unless otherwise specified
- FieldFox is within its calibration cycle
- Storage or operation at 25 °C ±5 °C range (unless otherwise stated)

### Typical (typ.):

Expected performance of an average unit over a 20 °C to 30 °C temperature range, unless otherwise indicated; does not include guardbands. It is not covered by the product warranty. The FieldFox RF VNA must be within its calibration cycle.

### Nominal (nom.):

A general, descriptive term or design parameter. It is not tested, and not covered by the product warranty.

## Network analysis

### Measurements

<b>S11, S21</b>	Magnitude and phase
<b>S12, S22</b>	Magnitude and phase (Option 122)
<b>Display:</b>	Log, linear, phase, group delay, VSWR, Smith chart, polar chart, split screen to show different S-parameters and phases
<b>System impedance selection:</b>	50 ohm and 75 ohm (with 50/75 ohm adapter)

## Frequency

### Frequency range

<b>Option 104:</b>	2 MHz to 4 GHz
<b>Option 106:</b>	2 MHz to 6 GHz

### Frequency reference

<b>Accuracy:</b>	±2 ppm
<b>Aging rate:</b>	±1 ppm
<b>Temperature stability:</b>	±1 ppm over -10 to 55 °C

### Frequency resolution

1 Hz

### Sweep speed

<b>S21, S11</b>	2 MHz to 6 GHz, 30 kHz IFBW, 1001 points 0.695 ms/point
-----------------	---

### Data points

101, 201, 401, 601, 801, 1001 (up to 10,001 using SCPI)

### Directivity

<b>Corrected:</b>	42 dB
-------------------	-------



## System dynamic range (S21)

2 MHz to 6 GHz: 100 dB (typical)

## IF bandwidth

300 Hz, 1 kHz, 3 kHz, 10 kHz, and 30 kHz

## Output power range

**High power:** +6 dBm (nominal)

**Low power:** -40 dBm (nominal)

## Trace noise (high output power, IF bandwidth = 300 Hz)

**Magnitude:** < 0.01 dB rms

## Immunity to interference

+16 dBm (nominal)

## Maximum input level port 1 or port 2

+23 dBm /±50 VDC

## Cable and antenna analyzer (Option 305)

### Capabilities

**Return loss**

**VSWR**

**Distance to fault (DTF):**

- Range =  $(n - 1) / (\text{span}^2) \times V_f$  (velocity factor in cable)  $\times C$  (light speed)
- Resolution = range/number of points
- Number of points: 101, 201, 401, 601, 801, 1001
- Distance to fault display: Return loss, VSWR, reflection coefficient

**Cable loss (1-port):** Terminated cable under test with short

**Transmission measurement (insertion loss and gain)**

### Calibration types

*CalReady*

One port mechanical calibration

Full 2-port mechanical calibration

Enhanced response calibration

*QuickCal* (1-port and 2-port)

Automatic cal update with frequency change

## Power meter measurement (Option 302)

### Frequency range

9 kHz to 24 GHz (sensor dependent)

### USB power sensor

9 kHz to 24 GHz: see Agilent U2000 Series USB power sensor specifications for details

## General specifications

### Connector type (port 1 and port 2)

Type N female

### Test port impedance

50 ohm

### External reference

<b>Input type:</b>	BNC female
<b>Reference frequency:</b>	10 MHz
<b>Required level:</b>	-5 dBm to 10 dBm

### External trigger input

<b>Impedance:</b>	10 k $\Omega$
<b>Level range:</b>	Rise edge: 17V; falling edge: 1V

### Display

6.5" transfective, color VGA LED backlit 640 x 480 with anti-glare coating

### Speaker

Built-in speaker

### Headphone jack

Built-in headphone jack

### Connectivity

2 x USB 2.0; 1 x micro USB; 1 x LAN

### GPS

Latitude, longitude, elevation, and accurate time are provided. The GPS information can be displayed on the screen and saved as part of the image or data file. The GPS capability is standard with all N9912A FieldFox RF analyzers. An external USB GPS receiver is required. Agilent recommends the Microsoft Streets & Trips, or Microsoft AutoRoute with GPS locator.

### Internal storage

Minimum 16 MB, up to 1000 traces

### External storage

1 x micro SD slot and 2 x USB 2.0



## EMC

Complies with European EMC Directive 2004/108/EC

- IEC/EN 61326-1
- CISPR Pub 11 Group 1, Class A
- AS/NZS CISPR 11
- ICES/NMB-001

## ESD

- IEC/EN 61000-4-2, functional up to 20 kV test

## Safety

Complies with European Low Voltage Directive 2006/95/EC

- IEC/EN 61010-1 2nd Edition
- Canada: CSA C22.2 No. 61010-1-04
- USA: UL 61010-1 2nd Edition

## Environmental

Compliant with MIL-PRF-28800F Class 2 general requirements - no exceptions

## Temperature

- Operating:** -10 °C to 55 °C  
**Non operating:** -51 °C to 71 °C

## Weight

6 lbs / 2.7 kg including battery

## Dimensions (H x W x D)

292 x 188 x 72 mm (11.5" x 7.4" x 2.8")

## Power

- Power supply**      **External DC input:** 15 to 19 VDC
- External AC power adapter**
- Input:** 100 to 250 VAC, 50 to 60 Hz; 1.25 to 0.56 A
- Output:** 15 VDC, 4 A
- Power consumption:** 14 W (typical)
- Battery:** 6 cell Lithium Ion, 10.8 V, 4.6 A-h
- Battery operating time:** 3.5 hours

## Language

English, Chinese, French, Spanish, Japanese, Russian, German, Italian, and Turkish

## N9923A FieldFox RF vector network analyzer options

Option 104	4 GHz RF vector network analyzer, transmission/reflection
Option 106	6 GHz RF vector network analyzer, transmission/reflection
Option 112	<i>QuickCal</i>
Option 122	Full 2-port S-parameters
Option 305	Cable and antenna analyzer
Option 302	External USB power sensor support
Option 308	Vector voltmeter

Standard accessories AC/DC adapter; battery; soft carrying case; LAN cable, Quick Reference Guide, and full manual

## N9910X RF/MW handheld analyzer accessories

N9910X-800	T-calibration kit, DC-6 GHz, Type-N(m)
N9910X-801	T-calibration kit, DC-6 GHz, Type-N(f)
N9910X-802	T-calibration kit, DC-6 GHz, 7/16 DIN(m)
N9910X-803	T-calibration kit, DC-6 GHz, 7/16 DIN(f)
85514A	4-in-1 OSLT Mechanical Calibration Kit, DC to 9 GHz, Type-N(m), 50 ohm
85515A	4-in-1 OSLT Mechanical Calibration Kit, DC to 9 GHz, Type-N(f), 50 ohm

N9910X-810	Rugged phase stable cable, Type-N(m) to Type-N(m), 5 ft
N9910X-811	Rugged phase stable cable, Type-N(m) to Type-N(f), 5 ft
N9910X-812	Rugged phase stable cable, Type-N(m) to Type-N(m), 12 ft
N9910X-813	Rugged phase stable cable, Type-N(m) to Type-N(f), 12 ft
N9910X-814	Rugged phase stable cable, Type-N(m) to 7/16(m), 60 inch or 1.5 m
N9910X-815	Rugged phase stable cable, Type - N(m) to 7/16(m), 12 ft or 3.6 m
N9910X-816	Phase stable cable, Type-N(m) to Type-N(f), 3.28 ft or 1 m
N9910X-817	Phase stable cable, Type-N(m) to Type-N(m), 3.28 ft or 1 m

N9910X-843	Coaxial adapter, Type-N(m) to 7/16 DIN(f)
N9910X-845	Adapter kit: Type-N(f) to 7/16 DIN(f), Type-N(f) to 7/16 DIN(m), Type-N(f) to Type-N(f)
N9910X-860	Fixed attenuator, 40 dB, 100 W, DC-3 GHz, Type-N(m) to Type-N(f)
N9910X-861	Fixed attenuator, 40 dB, 50 W, DC-8.5 GHz, Type-N(m) to Type-N(f)

N9910X-870	Extra battery
N9910X-872	External battery charger
N9910X-873	AD/DC adapter
N9910X-874	External bias-tee, 2.5 MHz to 6 GHz, 1 W, 0.5 A
N9910X-880	Extra soft carrying case with backpack and shoulder strap
N9910X-875	DC car charger and adapter

N9910X-881	Hard transit case
------------	-------------------

N9910X-884	Extra FieldFox shoulder strap
------------	-------------------------------

For more information go to: [www.agilent.com/find/fieldfox](http://www.agilent.com/find/fieldfox)

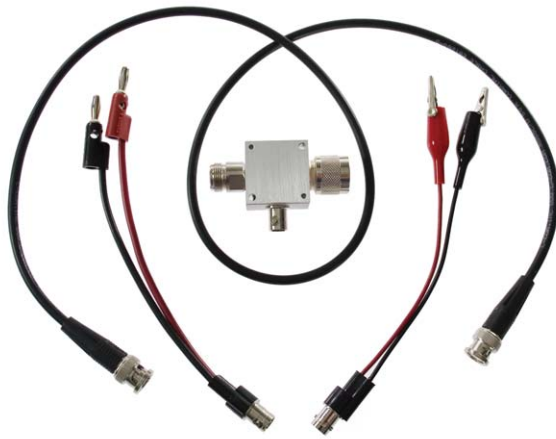

Bias-tee, N9910X-874



Phase stable cable, N9910X-810



100 Watt attenuator, N9910X-860



Adapter kit, N9910X-845



85514A



85515A



N9910X-800



N9910X-801



T-Cal kits

N9910X-802



N9910X-803



# FieldFox



Soft carrying case with backpack and shoulder straps included with a standard FieldFox.  
For an extra soft carrying case order N9910X-880.



Hard transit case, N9910X-881

AC/DC adapter, N9910X-873

FieldFox fits inside hard transit case

External battery charger,  
N9910X-872



### Agilent Email Updates

[www.agilent.com/find/emailupdates](http://www.agilent.com/find/emailupdates)

Get the latest information on the products and applications you select.

### Agilent Channel Partners

[www.agilent.com/find/channelpartners](http://www.agilent.com/find/channelpartners)

Get the best of both worlds: Agilent's measurement expertise and product breadth, combined with channel partner convenience.



Agilent Advantage Services is committed to your success throughout your equipment's lifetime. We share measurement and service expertise to help you create the products that change our world. To keep you competitive, we continually invest in tools and processes that speed up calibration and repair, reduce your cost of ownership, and move us ahead of your development curve.

[www.agilent.com/find/advantageservices](http://www.agilent.com/find/advantageservices)



[www.agilent.com/quality](http://www.agilent.com/quality)

[www.agilent.com](http://www.agilent.com)

[www.agilent.com/find/fieldfox](http://www.agilent.com/find/fieldfox)

[www.agilent.com/find/im\\_forum](http://www.agilent.com/find/im_forum)

For more information on Agilent Technologies' products, applications or services, please contact your local Agilent office. The complete list is available at:

[www.agilent.com/find/contactus](http://www.agilent.com/find/contactus)

#### Americas

Canada	(877) 894 4414
Brazil	(11) 4197 3500
Mexico	01800 5064 800
United States	(800) 829 4444

#### Asia Pacific

Australia	1 800 629 485
China	800 810 0189
Hong Kong	800 938 693
India	1 800 112 929
Japan	0120 (421) 345
Korea	080 769 0800
Malaysia	1 800 888 848
Singapore	1 800 375 8100
Taiwan	0800 047 866
Other AP Countries	(65) 375 8100

#### Europe & Middle East

Belgium	32 (0) 2 404 93 40
Denmark	45 70 13 15 15
Finland	358 (0) 10 855 2100
France	0825 010 700*
	*0.125 €/minute
Germany	49 (0) 7031 464 6333
Ireland	1890 924 204
Israel	972-3-9288-504/544
Italy	39 02 92 60 8484
Netherlands	31 (0) 20 547 2111
Spain	34 (91) 631 3300
Sweden	0200-88 22 55
United Kingdom	44 (0) 118 9276201

*For other unlisted Countries:*

[www.agilent.com/find/contactus](http://www.agilent.com/find/contactus)

Revised: October 14, 2010

Product specifications and descriptions in this document subject to change without notice.

© Agilent Technologies, Inc. 2010, 2011  
Printed in USA, March 21, 2011  
5990-5087EN

Photos throughout this document courtesy of:

U.S. Air Force

U.S. Marines

U.S. Army



**Agilent Technologies**