

## Table of Contents

Title	Page
Overview -----	3
Inspection -----	4
Safety Information -----	5
Rules For Safe Operation -----	6
International Electrical Symbols -----	8
The Meter Structure -----	9
Functional Buttons -----	9
Display Symbols -----	10
Measurement Operation -----	11
A. Measuring Resistance -----	11
B. Capacitance Measurement -----	13
C. Diode and Continuity Test -----	15
D. Transistor hFE Measurement -----	17
General Specifications -----	18
Accuracy Specifications -----	19
A. Resistance Test -----	19
B. Capacitance Test -----	20
C. Continuity & Diodes -----	20
D. Transistor -----	21
Maintenance -----	22
A. General Service -----	22
B. Replacing the Battery -----	23
C. Replacing the Fuse -----	24

**TENMA<sup>®</sup>**

**Model 72-8150: OPERATING MANUAL**

## Overview

This Operating Manual covers information on safety and cautions. Please read the relevant information carefully and observe all the **Warnings** and **Notes** strictly.

### **Warning**

**To avoid electric shock or personal injury, read the “Safety Information” and “Rules for Safety Operation” carefully before using the Meter.**

Digital Capacitance Meter **Model 72-8150** (hereafter referred to as “the Meter”) is a 3 1/2 digits with steady operations, fashionable design and highly reliable hand-held measuring instrument. It will measure resistance, transistor hFE and test diodes. It will also test continuity with an audible buzzer.

The Meter has a broad capacitance measurement range and precise accuracy. It can be used in measuring the circuit designed capacitance of cable, switch and PCB layout.

## Inspection

Open the package case and take out the Meter. Check the following items carefully to see if any items are missing or damaged.

Item	Description	Qty
1	English Operating Manual	1 piece
2	Test Clip	1 pair
3	9V Battery (NEDA1604, 6F22 or 006P) (installed)	1 piece

In the event you find any items missing or damaged, please contact your dealer immediately.

## Safety Information

This Meter complies with the standards EMC EN61326.

Use the Meter only as specified in this operating manual, otherwise the protection provided by the Meter may be impaired.

In this manual, a **Warning** identifies conditions and actions that pose hazards to the user, and may damage the Meter or the equipment under test.

A **Note** identifies the information that user should pay attention on.

International electrical symbols used on the Meter and in this Operating Manual are explained on page 8.

## Rules For Safe Operation









### Warning

To avoid possible electric shock or personal injury, and to avoid possible damage to the Meter or to the equipment under test, adhere to the following rules:

- 1 Before using the Meter inspect the case. Do not use the Meter if it is damaged or the case (or part of the case) is removed. Look for cracks or missing plastic. Pay attention to the insulation around the connectors.
- 1 Inspect the test clips for damaged insulation or exposed metal. Check the test clips for continuity. Replace damaged test clips with identical model number or electrical specifications before using the Meter.
- 1 Do not apply voltage to the Meter.
- 1 The rotary switch should be placed in the correct position and no change of range made during measurement, to prevent damage to the Meter.
- 1 Use the proper terminals, function, and range for your measurements.
- 1 Do not use or store the Meter in an environment of high temperature, humidity, explosive, inflammable and strong magnetic field. The performance of the Meter may deteriorate after dampened.
- 1 Disconnect circuit power and discharge all high-voltage capacitors before testing resistance, continuity, capacitance or diodes.
- 1 Replace the battery as soon as the battery indicator  appears. With a low battery, the Meter might produce false readings that can lead to electric shock and personal injury.
- 1 Remove test clips from the Meter and turn the Meter power off before opening the Meter case.

- 1 **When servicing the Meter, use only the same model number or identical electrical specifications replacement parts.**
- 1 **The internal circuit of the Meter shall not be altered at will to avoid damage of the Meter and any accident.**
- 1 **Soft cloth and mild detergent should be used to clean the surface of the Meter when servicing. No abrasive and solvent should be used to prevent the surface of the Meter from corrosion, damage and accident.**
- 1 **The Meter is suitable for indoor use.**  
**Turn the Meter power off when it is not in use and take out the battery when not using for a long time.**
- 1 **Periodically check the battery as it may leak after some time. If leakage is apparent, the battery should be immediately replaced to prevent damage to the Meter.**

## International Electrical Symbols

	Ground
	Double Insulated
	Low Battery.
	Continuity Test.
	Diode.
	Capacitance Test
	Fuse.
	Warning. Refer to the Operating Manual.
	Conforms to Standards of European Union.



## The Meter Structure (see figure 1)

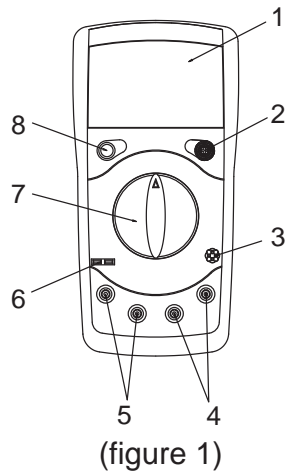

1. LCD Display
2. Capacitance Zero Adjustment Switch
3. Transistor Jack
4. Resistance, Diode and Continuity Buzzer Input Terminal
5. Capacitance Input Terminal
6. Small Value Capacitance Jack
7. Rotary Switch .
8. Power Button

## Functional Buttons

Below table indicated for information about the functional button operations.

Button	Description
<b>Power</b>	Press the <b>Power</b> down to turn the Meter on. Press the <b>Power</b> again to turn the Meter power off.

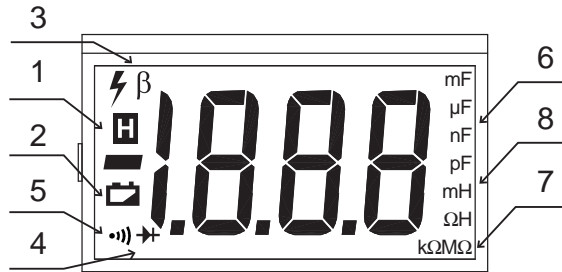

## Display Symbols (see figure 2)



(figure 2)

No.	Symbol	Meaning
1		Data hold is active.
2		The battery is low. ⚠ Warning: To avoid false readings, which could lead to possible electric shock or personal injury, replace the battery as soon as the battery indicator appears.
3	$\beta$	Transistor Test
4		Diode test
5		The continuity buzzer is on.
6	pF, nF, F, mF	Farad. The unit of capacitance pF: Picofarad. $1 \times 10^{-12}$ or 0.000000000001 farads. nF: Nanofarad. $1 \times 10^{-9}$ or 0.000000001 farads. $\mu$ F: Microfarad. $1 \times 10^{-6}$ or 0.000001 farads. mF: Millifarad. $1 \times 10^{-3}$ or 0.001 farads.
7	$\Omega$ , k $\Omega$ , M $\Omega$	$\Omega$ : Ohm. The unit of resistance k $\Omega$ : kilohm. $1 \times 10^3$ or 1000 ohms M $\Omega$ : Megaohm. $1 \times 10^6$ or 1,000,000 ohms
8	H, mH	H: Henry. The unit of Inductance. mH: Millihenry. $1 \times 10^{-3}$ or 0.001 henry.

## Measurement Operation

- 1 Make sure the Low Battery Display  is not on, otherwise false readings may be provided.
- 1 Pay extra attention to the  symbol, before carrying measurement, which is located besides the input terminals of the Meter.

### A. Measuring Resistance (see figure 3)

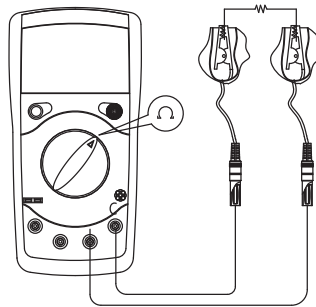

(figure 3)

### Warning

To avoid damage to the Meter or to the devices under test, disconnect circuit power and discharge all the high-voltage capacitors before measuring resistance.

The resistance ranges are 20Ω, 200Ω, 2kΩ, 20kΩ, 200kΩ, 2MΩ, 20MΩ, 200MΩ and 2000MΩ.

To measure resistance, please connect the Meter as follows:

1. Insert the red test clip into the  $\Omega$   terminal and the black test clip into **COM** terminal.
2. Set the rotary switch to  $\Omega$  range.
3. Connect the test clips across with the object being measured.

The measured value shows on the display.

**Note**

- 1 When measuring at 20Ω and 200Ω range, the test clips can add 0.1 to 0.3Ω error to resistance. To obtain precise readings in low-resistance measurements, short circuit the input terminals beforehand and record the reading obtained (called this reading as X). (X) is the additional resistance from the test clips.

Then use the equation:

measured resistance value (Y) – (X) = precision readings of resistance.

The Meter displays “1” when there is no input, for example, open circuit situation.

- 1 For high resistance measurement (>1MΩ), it normally requires several seconds to obtain a stable reading.
- 1 When resistance measurement has been completed, disconnect the connection between the test clips and the circuit under test and remove the test clips from the input terminals of the Meter.

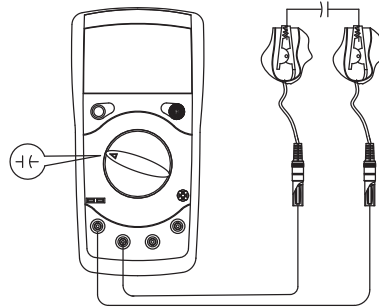
**B. Capacitance Measurement** (see figure 4)

(figure 4)

**⚠ Warning**

**To avoid damage to the Meter or to the equipment under test, disconnect circuit power and discharge all high-voltage capacitors before measuring capacitance.**

The Meter's capacitance ranges are: 200pF, 2nF, 20nF, 200nF, 2 $\mu$ F, 20 $\mu$ F, 200 $\mu$ F, 2mF and 20mF.

To measure capacitance, connect the Meter as follows:

1. Set the rotary switch to **F** measurement mode. If the value of capacitor to be measured is unknown, use the minimum measurement position 200pF and increase the range step by step until a satisfactory reading is obtained and the overload icon "1" is not showing.
2. Insert the red test clip into the **CAP +** terminal and black test clip into the **CAP -** terminal. For small value capacitor measurement, insert the capacitor into the **Small Value Capacitance Jack**.
3. When testing polarized capacitors, use the red test clip on the capacitor's positive lead, and the black test clip on the capacitor's negative lead. With non-polarized capacitors, either direction is acceptable.

4. When measuring small value capacitor, that is 200pF, 2nF and 20nF, first open circuit the test clips or the **Small Value Capacitance Jack**, then turn the **Capacitance Zero Adjustment Switch** to adjust zero.
5. The measured value shows on the display.

**Note**

- 1 Do not short the test clips to avoid the consumption of battery.
- 1 To minimize the effect of capacitance stored in the test clips, the test clips should be as short as possible and use the **Small Value Capacitance Jack** when measuring small value of capacitance.
- 1 When capacitance measurement has been completed, disconnect the connection between the test clips and the circuit under test and remove the test clips from the input terminals of the Meter.

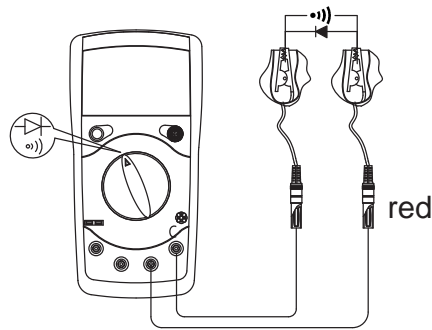
**C. Diode and Continuity Test** (see figure 5)

(figure 5)

**⚠ Warning**

To avoid damage to the Meter or to the devices under test, disconnect circuit power and discharge all the high-voltage capacitors before measuring diodes and continuity.

**Testing Diodes**

Use the diode test to check diodes, transistors, and other semiconductor devices. The diode test sends a current through the semiconductor junction, and then measures the voltage drop across the junction. A good silicon junction drops between 0.5V and 0.8V.

To test a diode out of a circuit, connect the Meter as follows:

1. Insert the red test clip into the  $\Omega \rightarrow \text{diode symbol}$  terminal and the black test clip into the **COM** terminal.
2. Set the rotary switch to  $\rightarrow \text{diode symbol}$ .
3. For forward voltage drop readings on any semiconductor component, place the red test clip on the component's anode and place the black test clip on the component's cathode.

The display shows the diode forward voltage drop's nearest value.

**Note**

- 1 In a circuit, a good diode should still produce a forward voltage drop reading of 0.5V to 0.8V; however, the reverse voltage drop reading can vary depending on the resistance of other pathways between the probe tips.
- 1 Connect the test clips to the proper terminals as said above to avoid error display. The LCD will display “1” indicating open-circuit for wrong connection. The unit of diode is Volt (V), displaying the positive-connection voltage-drop value.
- 1 When diode measurement has been completed, disconnect the connection between the test clips and the circuit under test and remove them from the input terminals of the Meter.

**Testing for Continuity**

To test for continuity, connect the Meter as below:

1. Insert the red test clip into the  $\Omega \rightarrow + \bullet \bullet \bullet$  terminal and the black test clip into the **COM** terminal.
2. Set the rotary switch to  $\rightarrow + \bullet \bullet \bullet$ .
3. Connect the test clips across with the object being measured.
4. The beeper sounds continuously when the test resistance  $< 120\Omega$ .
5. The Meter displays the value of the test resistance.

**Note**

- 1 The LCD displays “1” indicating the circuit being tested is open.
- 1 When continuity test has been completed, disconnect the connection between the test clips and the circuit under test and remove them from the input terminals of the Meter.

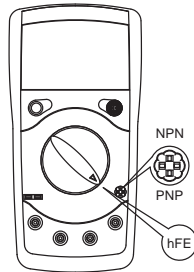

**D. Transistor hFE Measurement** (see figure 6)

(figure 6)



To measure transistor, set up the Meter as follows:

1. Check that the transistor is PNP or NPN type.
2. Insert the transistor to be measured to the corresponding **Transistor Jack**.
3. The Meter displays the tested transistor's nearest value.

**Note**

- 1 When transistor measurement has been completed, disconnect the connection between the test clips and the circuit under test and remove them from the input terminals of the Meter.

## General Specifications

- 1 Fused Protection for capacitance Input Terminal: 0.315A, 250V, fast type fuse,  $\phi 5 \times 20$  mm.
- 1 Maximum Display: Display: 1999.
- 1 Measurement Speed: Updates 2-3 times /second.
- 1 Polarity: Auto. (Display “-“ when negative)
- 1 Overload: Display “1”
- 1 Range: Manual Ranging
- 1 Capacitance range zero adjustment:  
The range around  $\pm 20$ pF
- 1 Temperature:  
Operating:  $0^{\circ}\text{C} \sim 40^{\circ}\text{C}$  ( $32^{\circ}\text{F} \sim 104^{\circ}\text{F}$ ).  
Storage:  $-10^{\circ}\text{C} \sim 50^{\circ}\text{C}$  ( $14^{\circ}\text{F} \sim 122^{\circ}\text{F}$ ).
- 1 Relative Humidity:  
 $\leq 75\%$  @  $0^{\circ}\text{C} - 30^{\circ}\text{C}$ ;  
 $\leq 50\%$  @  $31^{\circ}\text{C} - 40^{\circ}\text{C}$ .
- 1 Altitude:  
Operating: 2000 m.  
Storage: 10000 m.
- 1 Battery Type:  
One piece of 9V NEDA1604 or 6F22 or 006P.
- 1 Low Battery: Display 
- 1 Dimensions: 6.77" (H) x 3.27" (W) x 1.50" (D).
- 1 Weight: Approximate 310g (battery included).
- 1 Safety/Compliances: EMC EN61326.
- 1 Certification: , UL & CUL pending.

### Accuracy Specifications

Accuracy:  $\pm(a\% \text{ reading} + b \text{ digits})$ , guarantee for 1 year.

Operating temperature:  $23^{\circ}\text{C} \pm 5^{\circ}\text{C}$ .

Relative humidity:  $<75\%$ .

Temperature coefficient:  $0.1 \times (\text{specified accuracy}) / 1^{\circ}\text{C}$ .

#### A. Resistance Test

Range	Resolution	Accuracy	Overload Protection
20Ω	0.01Ω	$\pm(1\%+5)$	250V rms
200Ω	0.1Ω	$\pm(0.8\%+3)$	
2kΩ	0.001kΩ	$\pm(0.8\%+1)$	
20kΩ	0.01kΩ		
200kΩ	0.1kΩ		
2MΩ	0.001MΩ		
20MΩ	0.01MΩ	$\pm(1\%+2)$	
200MΩ	0.1MΩ	$\pm[5\%(\text{rdg}-10)+10]$	
2000MΩ	1MΩ	Reference only	

#### Remarks:

1 When measuring 20Ω and 200Ω range, the test clips can add 0.1 to 0.3Ω error to resistance. To obtain precise readings in low-resistance measurements, short circuit the input terminals beforehand and record the reading obtained (called this reading as X). (X) is the additional resistance from the test lead.

Then use the equation:

measured resistance value (Y) – (X) = precision readings of resistance



## B. Capacitance Test

Range	Resolution	Accuracy	Testing Frequency
200.0pF	0.1pF	±(0.5%+10)	800Hz
2.000nF	0.001nF		
20.00nF	0.01nF		
200.0nF	0.1nF		80Hz
2.000μF	0.001μF		
20.00μF	0.01μF		±(2%+2)
200.0μF	0.1μF		
2.000mF	0.001mF		
20.00mF	0.01mF		

### Remarks:

- 1 Overload Protection  
0.315A, 250V, fast type fuse, φ5x20 mm
- 1 If the Meter can not adjust to zero, you could use the tested values minus the open circuit value to get the correct measurement value.
- 1 Measure of Capacitance:  $1F=10^3mF = 10^6\mu F = 10^9nF = 10^{12}pF$

## C. Continuity & Diodes

Function	Range	Resolution	Overload Protection
Diode		1mV	250V rms
Continuity		1Ω	

### Remarks:

- 1 Diode:  
Open Circuit Voltage around 2.8V.
- 1 Continuity  
Around < 120Ω, beeper sounds continuously.

**D. Transistor**

Range	Resolution	Testing Condition	Overload Protection
hFE	1 $\beta$	V <sub>ce</sub> $\approx$ 2.8V I <sub>bo</sub> $\approx$ 10 $\mu$ A	250V rms

**Remarks:**

- 1 The display value is the tested transistor's nearest value (0~1000 $\beta$ ).

## Maintenance

This section provides basic maintenance information including battery and fuse replacement instruction.

### Warning

**Do not attempt to repair or service your Meter unless you are qualified to do so and have the relevant calibration, performance test, and service information.**

**To avoid electrical shock or damage to the Meter, do not allow water inside the case.**

#### A. General Service

- 1 Periodically wipe the case with a damp cloth and mild detergent. Do not use abrasives or solvents.
- 1 To clean the terminals with cotton bar with detergent, as dirt or moisture in the terminals can affect readings.
- 1 Turn the Meter power off when it is not in use and take out the battery when not using for a long time.
- 1 Do not store the Meter in a place of humidity, high temperature and strong magnetic field.

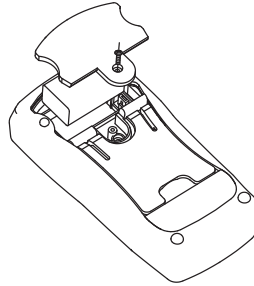
**B. Replacing the Battery** (see figure 7)

(figure 7)

**⚠ Warning**

**To avoid false readings, which could lead to possible electric shock or personal injury, replace the battery as soon as the battery indicator “” appears.**

To replace the battery:

1. Turn the Meter power off and remove all connections from the terminals.
2. Remove the screw from the battery compartment, and separate the battery compartment from the case bottom.
3. Remove the battery from the battery compartment.
4. Replace the battery with a new 9V battery (NEDA1604, 6F22 or 006P)
5. Replace the case bottom and battery compartment, and reinstall the screw.

### C. Replacing the Fuse (see figure 8)

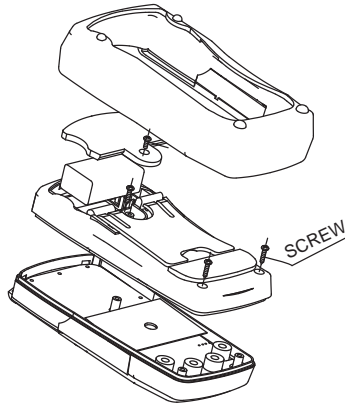

(figure 8)

#### **Warning**

**To avoid injury due to electrical shock or arc blast, and to avoid damage to the Meter, use specified fuses ONLY in accordance with the following procedure.**

To replace the Meter's fuse:

1. Turn the Meter power off and remove all connections from the terminals.
2. Remove the screw from the battery compartment, and separate the battery compartment from the case bottom.
3. Remove the screws from the case bottom, and separate the case top from the case bottom.
4. Remove the fuse by gently prying one end loose, then take out the fuse from its bracket.
5. Install **ONLY** replacement fuses with the identical type and specification as follows and make sure the fuse is fixed firmly in the bracket.  
Fuse 1: 0.315A, 250V, fast type fuse,  $\phi 5 \times 20$  mm.
6. Replace the battery compartment and the case top, and reinstall the screw.
7. Replace the case bottom and case top, and reinstall the screws.





Model 72-8150: OPERATING MANUAL

Fuse replacement is seldom required. Blown fuses are typically a result of improper use.

**\*\* END \*\***

This operating manual is subject to change without notice.



Model 72-8150: OPERATING MANUAL

©Copyright 2006 Tenma Test Equipment.  
All rights reserved.

Tenma Test Equipment  
405 S. Pioneer Blvd.  
Springboro, Ohio 45066  
[www.tenma.com](http://www.tenma.com)