



SOUTHCO SOFT-LATCH™
FLEXIBLE COVER DRAW LATCH

DATE	DRAWN	CHKD	SCALE	DRAWING NUMBER
7/13/89	RES		1:1	J-C7-20

REV.	DATE	BY-CHKD	REVISIONS	ITEM	COMPONENT	PART NO.	MATERIAL	FINISH
A	11/1/89	RES	UPDATED LATCH BODY PROFILE	ASSEMBLY		C7-20		
B	12-20-90	RHB	PRN C7-14		LATCH SUB-ASSL'Y		SEE NOTE 1	SEE NOTE 1
C	12 JAN. 93	KPL	PRN: S-1-03		KEEPER		304 STAINLESS STEEL	PASSIVATED
D	04DEC95	ALC	PRN C7-34					

NOTES:

- LATCH SUB-ASSEMBLY CONSISTS OF:
LATCH BODY - THERMOPLASTIC ELASTOMER, BLACK
LEVER AND BUSHINGS - GLASS REINFORCED NYLON, BLACK
PINS - 300 SERIES STAINLESS STEEL, PASSIVATED
BRACKET - 304 STAINLESS STEEL, PASSIVATED
RIVET - 430 STAINLESS STEEL, PASSIVATED
- MOUNT USING 3/16 RIVETS, No. 10, OR M5 SIZE HARDWARE.
- LATCH APPLIES APPROX. 40 lb STEADY STATE CLAMP LOAD AT ROOM TEMPERATURE.

CHANGE PART No. TO C7-20-B FOR BULK PACKAGED ASSEMBLIES.

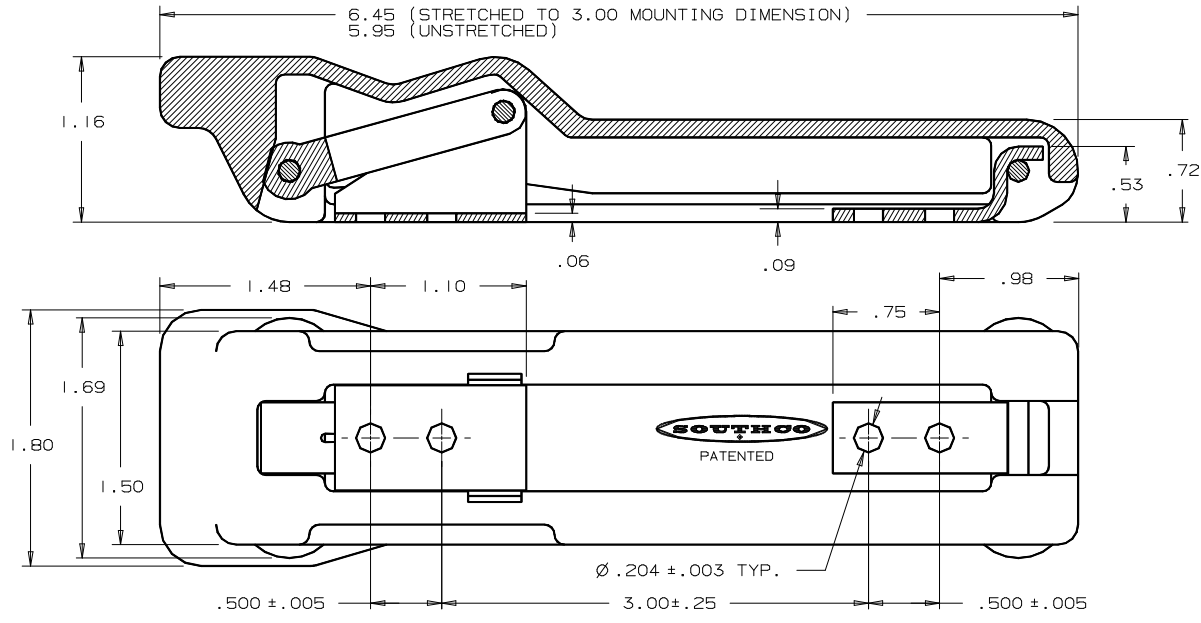

MOUNTING DIMENSIONS TOLERANCE ON ENVELOPE DIMENSIONS ±.02

FORMAT 3/88

PROPRIETARY ITEM - EXCEPT FOR USES EXPRESSLY GRANTED IN WRITING INFORMATION DISCLOSED HEREON IS CONFIDENTIAL AND ALL RIGHTS PATENT AND OTHERWISE ARE RESERVED BY SOUTHCO, INC.

PATENTED

DRAWING NUMBER
J-C7-20