

NOTES:

1. SAME AS E3-55-15 EXCEPT 7 ADDITIONAL PAWLS AND KEY INCLUDED.
2. INSTALLATION: SECURE LATCH SUBASSEMBLY IN DOOR WITH LARGE LOCKWASHER AND MOUNTING NUT (19 ACROSS FLATS). PLACE PAWL NUTS (10 ACROSS FLATS) AND LOCKWASHERS ON SHAFT AND ADJUST TO REQUIRED GRIP IN LATCHED POSITION. TIGHTEN NUTS SECURELY.
3. CAUTION: SET PAWL POSITION SO THAT NO MORE THAN 1.6 Nm OF TORQUE IS REQUIRED TO SECURE THE DOOR.
4. OPERATION: 195° TURN OF DRIVER OR KNOB CAUSES PAWL TO ROTATE AND THEN PULL UP AS SHOWN.

southco			PROPRIETARY ITEM - EXCEPT FOR USES EXPRESSLY GRANTED IN WRITING INFORMATION DISCLOSED HEREON IS CONFIDENTIAL AND ALL RIGHTS, PATENT AND OTHERWISE ARE RESERVED BY SOUTHCO, INC.			E3 SMALL SIZE VISE ACTION™ LATCHES, STAINLESS STEEL			DATE	DRAWN	CHKD	SCALE	DRAWING NUMBER
									21SEP2007	KPL	MJS	1.5:1	J-E3-99-1263
REV	DATE	DRAWN/CHKD	DESCRIPTION	ITEM	MATERIAL	FINISH	ITEM	MATERIAL	FINISH	MILLIMETERS			
				HOUSING	316L STAINLESS STEEL	ELECTROPOLISHED	PIN	STEEL-ZINC PLATE	CHROMATE PLUS SEALER, PASSIVATED	ALL DIMENSIONS WITHOUT TOLERANCES ARE FOR REFERENCE ONLY.			
				CAM	1075 CASE HARDENED STEEL	DACROTIZED™	PAWL	304 STAINLESS STEEL	CHROMATE PLUS SEALER, PASSIVATED				
				CAP/KNOB	316L STAINLESS STEEL	ELECTROPOLISHED	M6 NUT (2)	304 STAINLESS STEEL	CHROMATE PLUS SEALER, PASSIVATED				
				SHAFT	316 STAINLESS STEEL	---	LOCKWASHER (2)	302 STAINLESS STEEL	CHROMATE PLUS SEALER, PASSIVATED				
				SPRING	302 STAINLESS STEEL	PASSIVATED	LOCKWASHER	302 STAINLESS STEEL	CHROMATE PLUS SEALER, PASSIVATED				
				SLEEVE	1095 CASE HARDENED STEEL	DACROTIZED™	MOUNTING NUT	304 STAINLESS STEEL	CHROMATE PLUS SEALER, PASSIVATED				
				RETAINER	302 STAINLESS STEEL	PASSIVATED	CAP(TUBULAR KEY)	303 STAINLESS STEEL	CHROMATE PLUS SEALER, PASSIVATED				
				O-RING	BUNA N	---	FLANGE GASKET	NEOPRENE	NATURAL				
				KEY	DIE CAST ZINC	PROTECTIVE COATING							

ASSEMBLY PART NUMBER
E3-99-1263

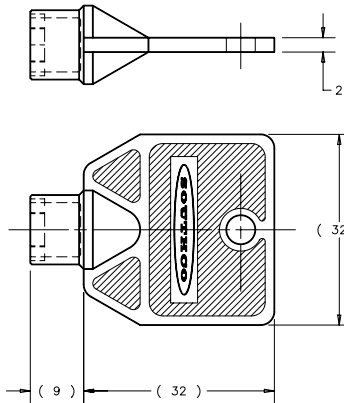

SOUTHCO TUBULAR KEY (SOUTHCO KEY PART No. E3-26-819-19 INCLUDED.)

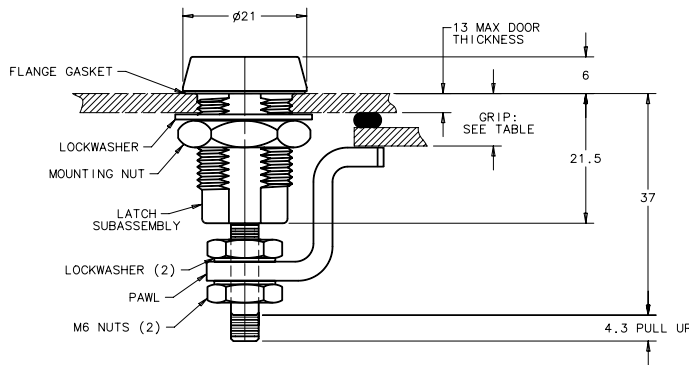
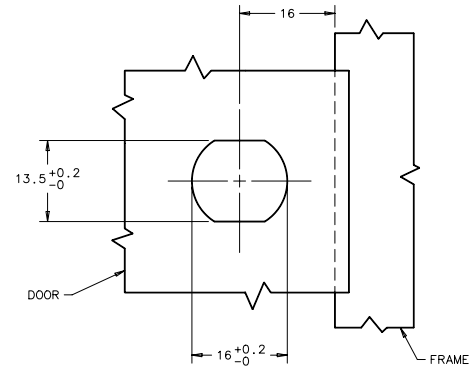
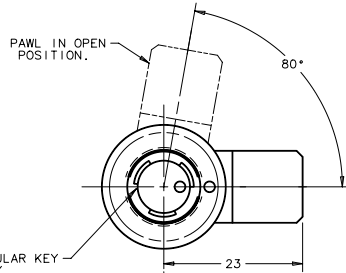

PAWL TYPE	GRIP	
	MIN.	MAX.
1	3.2	6.4
2	6	9.5
3	9.5	12.7
4	12.7	15.9
5	15.9	19
6	19	22.2
7	22.2	25.4
8	25.4	28.6

™METAL COATINGS INTERNATIONAL, INC.