

Southco® A3 Push-to-Close Latch

Visible, Locking, Snap-In Installation

- Single hole, snap-in installation
- Integrated Lock
- Corrosion-resistant materials

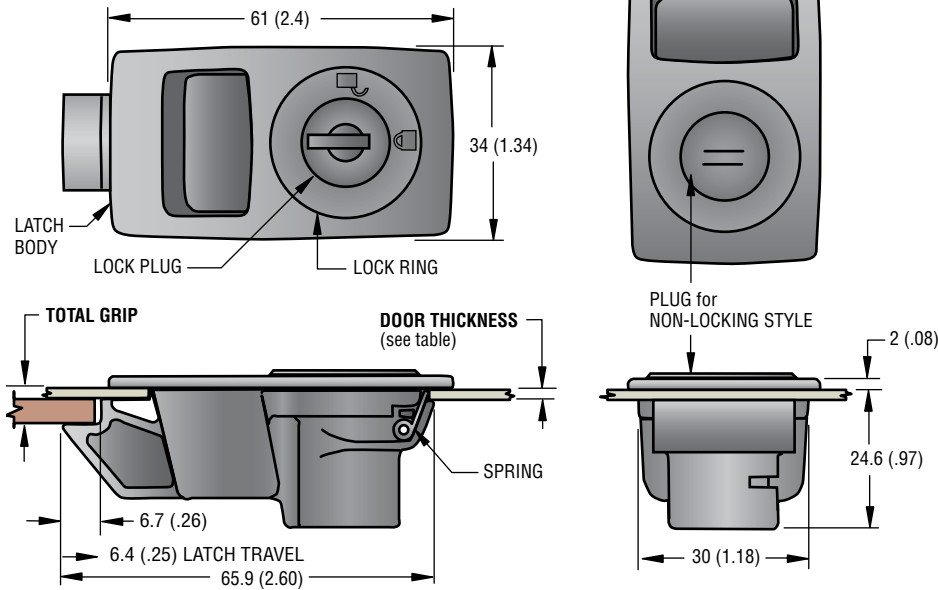

Push-to-Close Latches

Material and Finish

LATCH BODY: ABS, black
 LOCK RING and HOLE PLUG (non-locking): ABS, black
 LOCK PLUG: Glass reinforced nylon, black
 SPRING: 302 stainless steel, passivated
 KEYS: Brass, nickel plated with ABS, black (overmolded style only)

Product Strength Guidelines

(To assist in your product selection; samples are available for your evaluation.)

Flammability Rating: UL94 - V0

Operating Temperature Range:

- 40°C (-40° F) to 60°C (140° F)

GRIP		TOTAL GRIP	PART NUMBERS	
DOOR THICKNESS MIN.	DOOR THICKNESS MAX.		LOCKING*	NON-LOCKING
.9 (.035)	1.2 (.047)	6.4±0.1 (.250±.005)	A3-85-525-12 •	A3-80-525-12 •
1.3 (.051)	1.6 (.062)		A3-85-625-12 •	A3-80-625-12 •

Key PART NUMBERS	
Flat Keys (2 per ring)	PK-10-01 •
Overmolded Keys (2 per ring)	PK-10-01-05 •

*Locking version is shipped without keys. Key code CH 751 must be ordered separately.

Installation

1. Prepare burr-free hole.

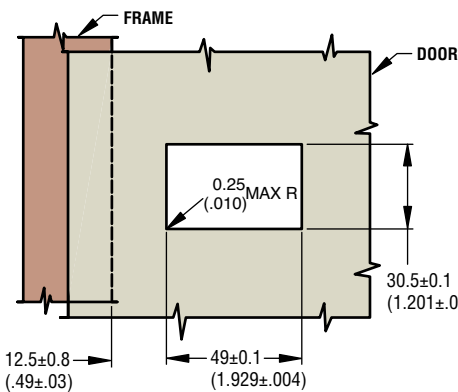

2. Slip front of latch through hole. Push forward.

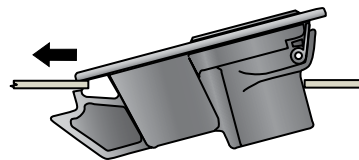

3. Snap back end of latch into position.

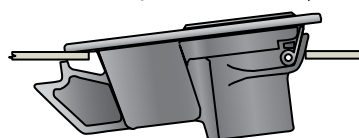

millimeter (inch)
 millimeter
 (inch)

Dimensions without tolerances are for reference only.

Southco® Push to Close Latches

Slide Latch, Ergo-tab Style

- Slide to open
- UL94-V0 rated flame retardant material
- Non-corrosive materials
- Single-hole, snap-in installation



Push to Close Latches Visible

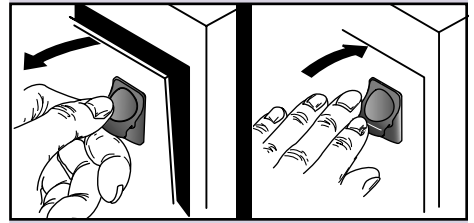
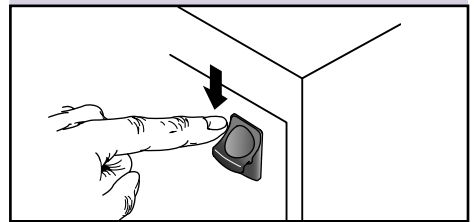
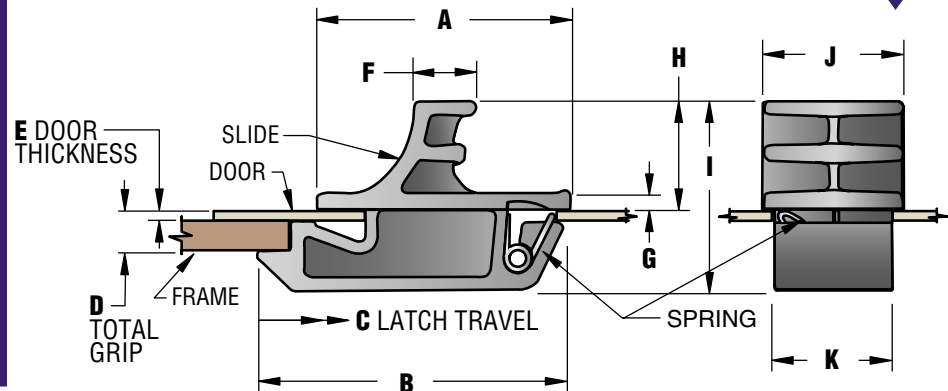

GRIP		DIMENSIONS									PART NUMBER	SIZE
E DOOR THICKNESS	D TOTAL GRIP	A	B	C	F	G	H	I	J	K		
1 ± 0.1 (.04±.005)	3 ± 0.1 (.12±.005)	19 (.75)	22.2 (.87)	4 (.16)	5.1 (.20)	1.5 (.06)	8.3 (.33)	15.5 (.61)	9.5 (.37)	7.6 (.30)	A3-70-412-25 •	Medium
1.2 ^{+0.2} ₀ (.05±.005)	4.8 ± 0.1 (.19±.005)	30.1 (1.19)	36.2 (1.43)	4.3 (.17)	7.2 (.28)	2.2 (.09)	12.8 (.50)	22.4 (.88)	16.5 (.65)	14 (.55)	A3-60-519-25 •	Large

For custom colors contact Southco.

Installation

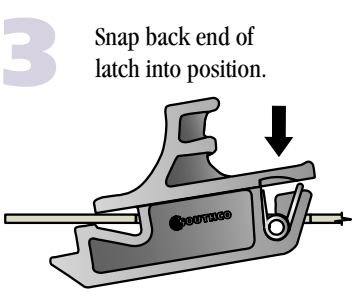
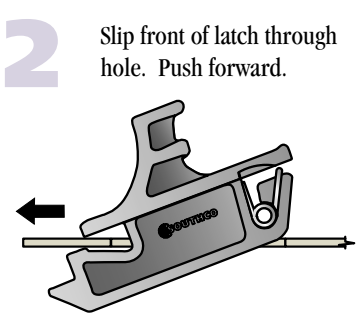
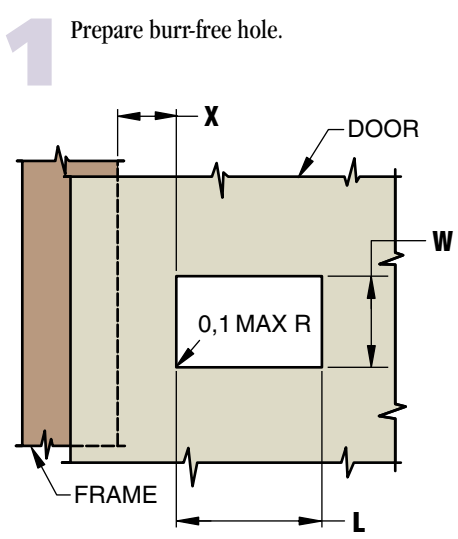

SIZE	INSTALLATION		
	L	W	X
Medium	12.7 ± 0.1 (.500 ± .005)	7.8 ± 0.05 (.307 ± .002)	6.4 ± 0.8 (.25 ± .03)
Large	22.2 ± 0.1 (.875 ± .005)	14.3 ± 0.1 (.562 ± .005)	9.5 ± 0.8 (.38 ± .03)

Material and Finish

LATCH BODY: ABS black, UL94 V0.
 SPRING: 302 Stainless steel, passivated.

Product Strength Guidelines

(To assist in your product selection; samples are available for your evaluation.)

Medium:

Maximum static load : 90 N (20 lbs.)
 Average ultimate load : 130 N (29 lbs.)

Large:

Maximum static load : 150 N (33 lbs.)
 Average ultimate load : 210 N (47 lbs.)

Operating Temperature Range:

- 40°C (-40° F) to 60°C (140° F)

millimeter (inch)
 millimeter
 (inch)

Dimensions without tolerances are for reference only.

Southco® Push to Close Latches

Slide Latch, Tab Style

- Now available in three sizes
- Slide to open
- Single-hole, snap-in installation
- Non-corrosive materials

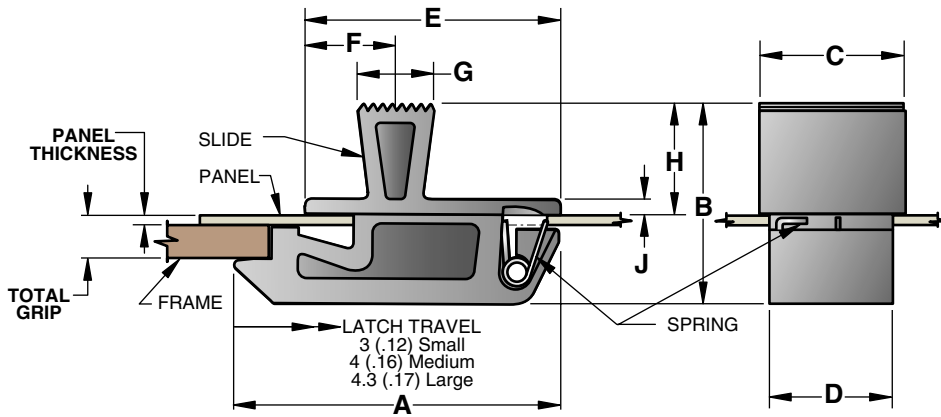

GRIP		DIMENSIONS										PART NUMBER	SIZE
PANEL THICKNESS	TOTAL GRIP	A	B	C	D	E	F	G	H	J			
.76 ± .08 (.030 ± .003)	2.54 ± 0.13 (.100 ± .005)	15.1 (.59)	11.1 (.44)	6.0 (.23)	4.4 (.17)	11.9 (.47)	4.4 (.17)	4.0 (.16)	5.6 (.22)	0.8 (.03)	A3-10-310-12 •	Small	
1 ± 0.1 (.040 ± .005)	3 ± 0.1 (.120 ± .005)	22.5 (.87)	15.5 (.61)	9.5 (.37)	7.5 (.30)	18 (.70)	6.5 (.26)	5.5 (.22)	8.5 (.33)	1.5 (.06)	A3-20-412-12 •	Medium	
1.2 ± 0.1 (.050 ± .005)	4.8 ± 0.1 (.190 ± .005)	36 (1.41)	22.5 (.88)	16.5 (.64)	14 (.55)	29 (1.13)	10.5 (.41)	9 (.34)	13 (.50)	2 (.08)	A3-30-519-12 •	Large	

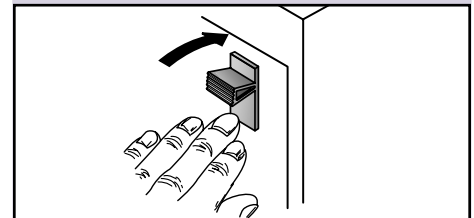
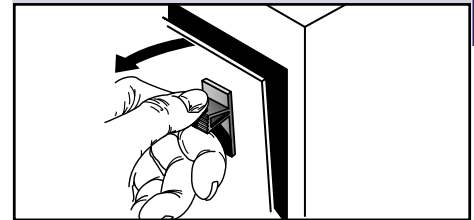
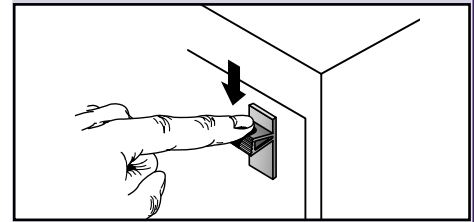
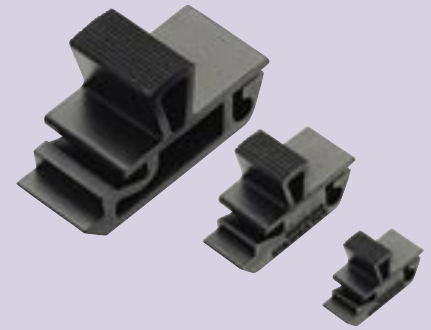

Push to Close Latches
Visible

Installation

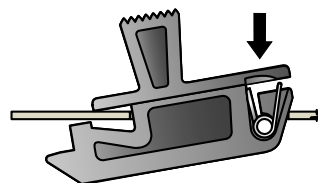
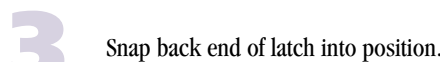
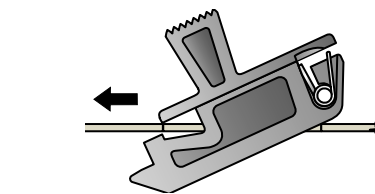
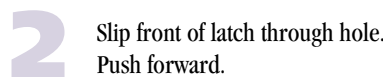
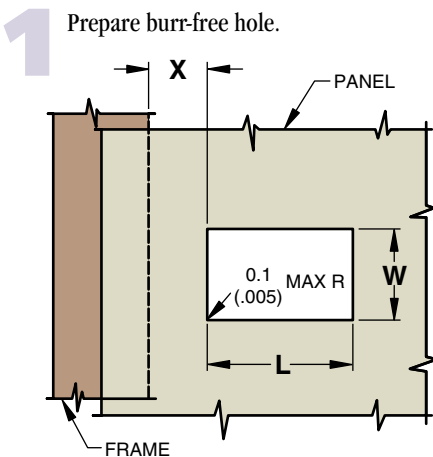

SIZE	INSTALLATION		
	L	W	X
Small	8.33±0.05 (.328±.002)	4.57±0.05 (.180±.002)	4.8±0.8 (.19±.03)
Medium	12.7±0.1 (.500±.005)	7.8±0.05 (.307±.002)	6.4±0.8 (.25±.03)
Large	22.2±0.1 (.875±.005)	14.3±0.1 (.562±.005)	9.5±0.7 (.38±.03)

Material and Finish

LATCH BODY: ABS black or Acetal
SPRING: 302 Stainless steel, passivated.

Product Strength Guidelines

(To assist in your product selection; samples are available for your evaluation.)

Maximum static load for:

Small Size: 25 N (5 lbs.)

Medium Size: 90 N (20 lbs.)

Large Size: 130 N (30 lbs.)

Average ultimate load for:

Small Size: 145 N (30 lbs.)

Medium Size: 150 N (34 lbs.)

Large Size: 310 N (70 lbs.)

Flammability Rating: UL94 - HB

Operating Temperature Range:

- 40°C (-40° F) to 60°C (140° F)

millimeter (inch)
millimeter
(inch)

Dimensions without tolerances are for reference only.

Southco® Push to Close Latches

Slide Latch, Flush Style

- Slide to open
- Single-hole, snap-in installation
- Corrosion-resistant materials
- Three sizes

Push to Close Latches Visible

Series 40 and 50

Series 99 (deeper depression)

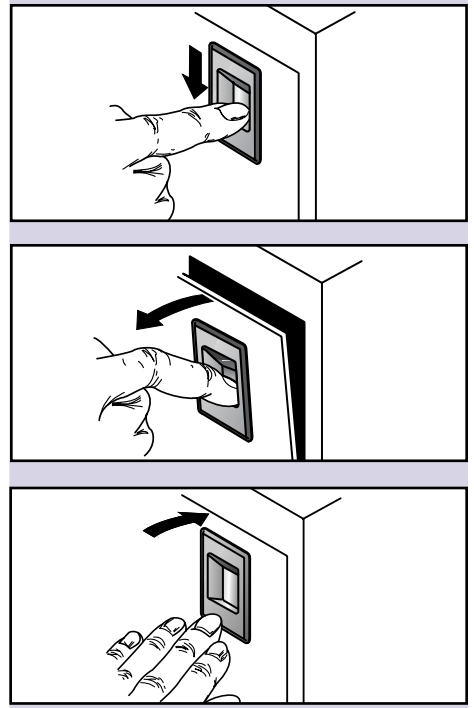
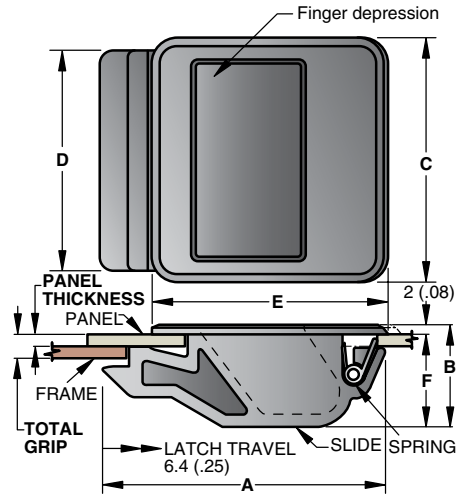
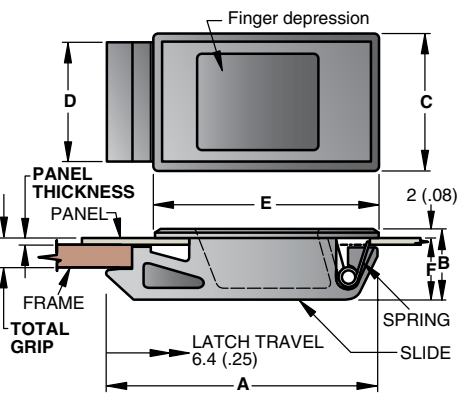

SIZE	GRIP		DIMENSIONS						PART NUMBER	
	Panel Thickness	Total Grip	A	B	C	D	E	F	UL94-HB	UL94-V0
Series 40	1.2 ± 0.1 (.050 ± .005)	6.4 ± 0.1 (.250 ± .005)	57 (2.23)	15 (.58)	28 (1.11)	25 (.99)	47 (1.84)	13 (.50)	A3-40-525-12 •	A3-99-187-12
	1.6 ⁺⁰ _{-0.2} (.060 ± .005)	6.4 ± 0.1 (.250 ± .005)	57 (2.23)	15 (.58)	28 (1.11)	25 (.99)	47 (1.84)	13 (.50)	A3-40-625-12 •	A3-99-130-12
Series 50	2.2 ^{+0.2} _{-0.0} (.090 ± .005)	6.4 ± 0.1 (.250 ± .005)	57 (2.23)	15 (.58)	47 (1.86)	44 (1.74)	47 (1.84)	13 (.50)	A3-50-925-12 •	A3-99-144-12
Series 99	2.2 ^{+0.2} _{-0.0} (.090 ± .005)	6.4 ± 0.1 (.250 ± .005)	57 (2.23)	21 (.81)	50 (1.95)	44 (1.74)	48 (1.87)	19 (.74)	A3-99-122-12 •	A3-99-253-01

Installation

1. Prepare burr-free hole.
2. Slip front of latch through hole. Push forward.

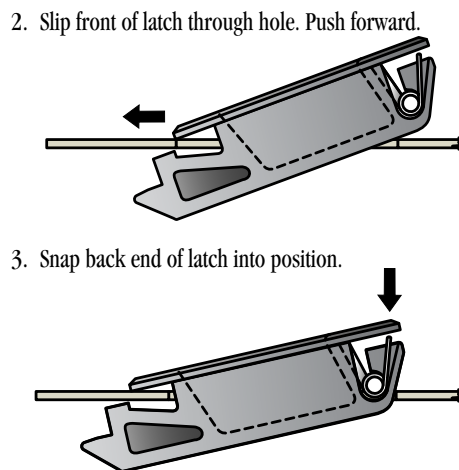
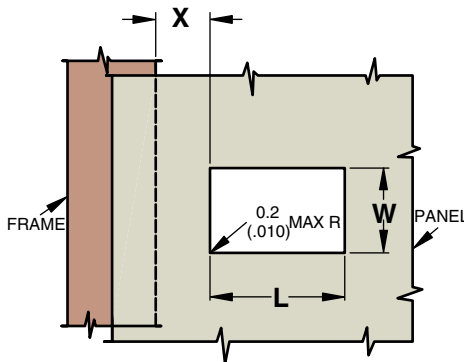

3. Snap back end of latch into position.

SERIES	INSTALLATION		
	L	W	X
40	38 ^{+0.2} _{-0.0} (1.500 ± .005)	25.5 ^{+0.0} _{-0.2} (1.00 ± .005)	12.5 ^{+1.0} _{-0.5} (.50 ± .03)
50	38 ^{+0.2} _{-0.0} (1.500 ± .005)	44.5 ± 0.1 (1.75 ± .005)	12.5 ^{+1.0} _{-0.5} (.50 ± .03)
99	38 ^{+0.2} _{-0.0} (1.500 ± .005)	44.5 ± 0.1 (1.75 ± .005)	12.5 ^{+1.0} _{-0.5} (.50 ± .03)

Material and Finish

SLIDE: Black ABS, textured.
SPRING: 302 Stainless steel, passivated.

Product Strength Guidelines

(To assist in your product selection; samples are available for your evaluation.)

Average ultimate load:

580 N (130 lbs.)

Maximum static load for:

40 Series: 180 N (40 lbs.)

50 and 99 Series: 220 N (50 lbs.)

Flammability Rating: UL94 - HB or UL94-V0

Operating Temperature Range:
- 40°C (-40°F) to 60°C (140°F)

millimeter (inch)
millimeter (inch)

Dimensions without tolerances are for reference only.