

# PAWL LATCHES - DP109 Series

A miniature version of the popular DP 106 series with projection into a cabinet of less than 25mm (1"). The Pawl is operated by rotating the knurled or slotted head, which also provides adjustment for locking tension.

## INSTALLATION

- 1 Prepare panel as shown in fig. 1 using a 10mm. drill or punch.
- 2 Unscrew pawl to its maximum grip position and ensure that pawl is in centre of the barrel opening, remove locknut (2).
- 3 Insert barrel (1) into hole and ensure that flats and barrel are in position shown in figure 2.
- 4 Thread locknut (2) on barrel and wrench securely maintaining barrel in the correct position. The miniature Pawl Latch is ready for operation.

As this latch is supplied fully assembled, it is offered with a short or long grip and this condition must be specified when ordering.

Part numbers for the choice of head style and choice of finish are as follows:

knurled head	zinc plated	short grip DP-109-S	long grip DP-109-L
knurled head	chrome plated	short grip DP-109-SC	long grip DP-109-LC
slotted head	zinc plated	short grip DP-109-SA	long grip DP-109-LA
slotted head	chrome plated	short grip DP-109-SAC	long grip DP-109-LAC

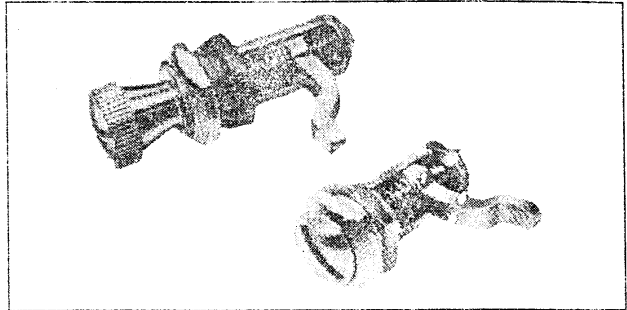

## PANEL THICKNESS RANGE

.023" min. - .130 max. (0.58-3.30)

## GRIP RANGE

a) Short grip (Pawl curved towards panel)  
.050" min. - .450" max. (1.27 - 11.43)

b) Long grip (Pawl curved away from panel)  
.375" min. - .750" max. (9.5 - 19.0)

