

RoHS Directive compatibility information
<http://www.mew.co.jp/ac/e/environment/>

FEATURES

1. The world's smallest* with a built-in amplifier

Extremely compact. Ideal for use in miniaturized devices.

(*Based on our investigation as of November, 2006)

2. Dual lens colors (white and black) are available

With an ultras small design and dual lens colors (white and black), it is inconspicuous, allowing the user to select either white or black to match the equipment color. This provides greater flexibility in equipment design.

3. Both digital output and analog output (with adjustable sensitivity) are available.

Has a built-in amplifier, and can be connected directly to a microcomputer.

• Block diagram of the digital output circuit

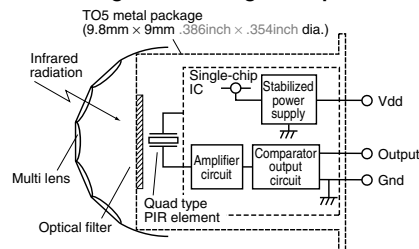

• Block diagram of the analog output circuit

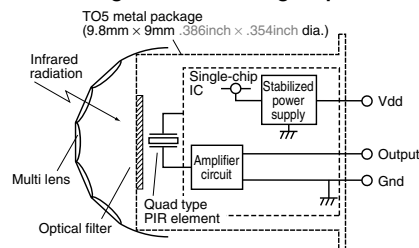

5. Detects even slight motion of a person

With our sensor, even slight motions made by people will be detected easily.

• Fine motion detection capability within approximately 2 meters of sensor.

Standard type:

Detects movement of approximately 30cm 11.811inch.

Slight motion detection type:

Detects movement of approximately 20cm 7.874inch.

6. Noise withstanding capability

Circuitry is contained in a TO5 metal package, providing at least twice the noise withstanding capability as conventional type.

• Comparison example of noise withstanding capability

| | Distance at which motion sensor is not affected by cellular phone noise |
|-------------------|---|
| Conventional type | Min. 1 to 2m 3.281 to 6.562ft |
| MP Motion Sensor | Min. 1 to 2cm .394 to .787inch |

7. A low current consumption type (46 µA) has also been added to the lineup.

A type that keeps current consumption to 46 µA (less than 30% compared to predecessor) is now available. Ideal for battery driven devices.

*Digital output type only.

8. A more economically priced digital output type (ST type) has been launched.

APPLICATIONS

1. Home appliances

Useful for saving energy in air conditioner, television, personal computer, or ventilator and air purifier

2. Amusement machine market

Useful for saving energy and for automated guidance in theme parks and large video games

3. Equipment in service market

Useful for automated guidance, automated announcements and energy saving in vending machines, ATMs, etc.

4. Lighting market

Automated on/off controls, etc. for lamps, desk lamps, indoor lights, halls, stairway lights, etc.

ORDERING INFORMATION

| | AMN | | 1 | | |
|---------------------------------|-----|--|---|--|--|
| Output | | | | | |
| 2: Analog output | | | | | |
| 3: Digital output (ST type) | | | | | |
| Detection performance | | | | | |
| 1: Standard detection type | | | | | |
| 2: Slight motion detection type | | | | | |
| 3: Spot detection type | | | | | |
| 4: 10m detection type | | | | | |
| Feature | | | | | |
| 1: PC board mounting type | | | | | |
| Operating voltage | | | | | |
| 1: 5V DC | | | | | |
| 2: 3V DC | | | | | |
| Lens color | | | | | |
| 1: Black | | | | | |
| 2: White | | | | | |

MP MOTION SENSOR 'NaPiOn'
ASCT1B324E '06.12

New

MP Motion Sensor (AMN2, 3, 4)

PRODUCT TYPES

1. Digital output

| Rated operating voltage | Detection performance | | Ambient temperature | Lens color | Part No. | Packing quantity | |
|--|------------------------------|-------------------------|------------------------------|------------|----------|------------------|------------|
| | | | | | | Inner | Outer |
| 3 to 6 V DC 2.2 to 3 V DC (Low current consumption type) | Standard detection type | Standard | -20 to +60°C -4 to +140°F | Black | AMN31111 | 50 pcs. | 1,000 pcs. |
| | | | | White | AMN31112 | | |
| | | Black | | AMN41121 | | | |
| | | White | | AMN41122 | | | |
| | Slight motion detection type | Standard | | Black | AMN32111 | | |
| | | | | White | AMN32112 | | |
| | | Low current consumption | | Black | AMN42121 | | |
| | | | | White | AMN42122 | | |
| | Spot detection type | Standard | | Black | AMN33111 | | |
| | | | | White | AMN33112 | | |
| | | Low current consumption | | Black | AMN43121 | | |
| | | | | White | AMN43122 | | |
| | 10m detection type | Standard | | Black | AMN34111 | | |
| | | | | White | AMN34112 | | |
| | | Low current consumption | | Black | AMN44121 | | |
| | | | | White | AMN44122 | | |

2. Analog output

| Rated operating voltage | Detection performance | | Ambient temperature | Lens color | Part No. | Packing quantity | |
|-------------------------|------------------------------|------------------------------|---------------------|------------|----------|------------------|-------|
| | | | | | | Inner | Outer |
| 4.5 to 5.5 V DC | Standard detection type | -20 to +60°C -4 to +140°F | Black | AMN21111 | 50 pcs. | 1,000 pcs. | |
| | | | White | AMN21112 | | | |
| | Slight motion detection type | | Black | AMN22111 | | | |
| | | | White | AMN22112 | | | |
| | Spot detection type | | Black | AMN23111 | | | |
| | | | White | AMN23112 | | | |
| | 10m detection type | | Black | AMN24111 | | | |
| | | | White | AMN24112 | | | |

PERFORMANCE

1. Detection performance

| Items | | Standard detection type | Slight motion detection type | Spot detection type | 10m detection type | Conditions of objects to be detected |
|--|--|-------------------------|------------------------------|---------------------|---------------------|--------------------------------------|
| Rated detection distance <small>*Remark 1</small> | | 5m 16.404ft (Max.) | 2m 6.562ft (Max.) | 5m 16.404ft (Max.) | 10m 32.808ft (Max.) | |
| Detection range | Horizontal <small>*Remark 2</small> | 100° | 91° | 38° | 110° | |
| | Vertical <small>*Remark 2</small> | 82° | 91° | 22° | 93° | |
| | Detection zone <small>*Remark 3</small> | 64 zones | 104 zones | 24 zones | 80 zones | |

*Remarks 1. Depending on the difference in temperature between the background and detection target and the speed at which the target moves, these sensors may be capable of detection beyond the detection distances stated above. Nevertheless, they should be used within the prescribed detection distances. For further details, refer to the detection range diagram on page 4.

*Remarks 2.

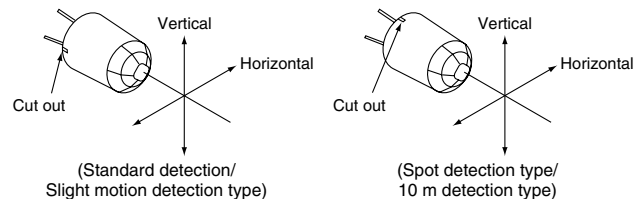

*Remarks 3. Regarding of detection zone, please refer to "DETECTION PERFORMANCE" on page 4.

2. Rating (Measuring condition: ambient temp. = 25°C 77°F) (Common to All types)

| Items | Specified value | Remarks |
|----------------------------|--------------------------|--|
| Power supply voltage | -0.3 to 7 V DC | |
| Usable ambient temperature | -20 to 60°C -4 to +140°F | No freezing and condensing at low temperature. |
| Storage temperature | -20 to 70°C -4 to +158°F | |

MP Motion Sensor (AMN2, 3, 4)

3. Electrical characteristics (Measuring condition: ambient temp. = 25°C 77°F; operating voltage = 5V) (Common to All types)

1) Digital output

| Items | | Symbol | Specified value | | Measured conditions |
|--|---------|--------|-----------------|------------------------------|-------------------------|
| | | | Standard type | Low current consumption type | |
| Rated operating voltage | Minimum | Vdd | 3.0 V DC | 2.2 V DC | |
| | Typical | | — | — | |
| Rated consumption current (Standby)*Remark | Maximum | Iw | 6.0 V DC | 3.0 V DC | Iout = 0 |
| | Typical | | 170 μA | 46 μA | |
| Output (when detecting) | Maximum | Iout | 300 μA | 60 μA | Vout ≥ Vdd-0.5 |
| | Current | | 100 μA | 100 μA | |
| Output (when not detecting) | Minimum | Vout | Vdd - 0.5 | Vdd - 0.5 | Open when not detecting |
| | Voltage | | — | — | |
| Circuit stability time | Typical | Twu | 7 s | 7 s | |
| | Maximum | | 30 s | 30 s | |

Remark: The current which is consumed during detection consists of the standby consumed current plus the output current.

2) Analog output

| Items | | Symbol | Specified value | Measured conditions |
|-------------------------------|---------|--------|-----------------|--|
| Rated operating voltage | Minimum | Vdd | 4.5 V DC | |
| | Maximum | | 5.5 V DC | |
| Rated consumption current | Typical | Iw | 0.17 mA | Iout = 0 |
| | Maximum | | 0.3 mA | |
| Output current | Maximum | Iout | 50 μA | |
| Output voltage | Minimum | Vout | 0 V | |
| | Typical | | 2.5 V | |
| | Maximum | | Vdd | |
| Output offset average voltage | Minimum | Voff | 2.3 V | Steady-state output voltage when not detecting |
| | Typical | | 2.5 V | |
| | Maximum | | 2.7 V | |
| Steady-state noise | Typical | Vn | 155 m Vp-p | |
| | Maximum | | 300 m Vp-p | |
| Circuit stability time | Maximum | Twu | 45 s | |

Note: To set to the same detection performance as the digital type, set the output voltage to the offset voltage (2.5V) ±0.45V (i.e. 2.95V or more and 2.05V or less).

[Timing chart]

1) Digital output

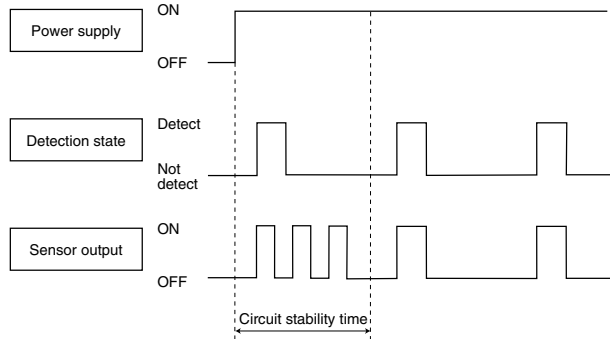

Remark:
Circuit stability time: 30s max.
While the circuitry is stabilizing after the power is turned on, the sensor output is not fixed in the "on" state or "off" state. This is true regardless of whether or not the sensor has detected anything.

2) Analog output

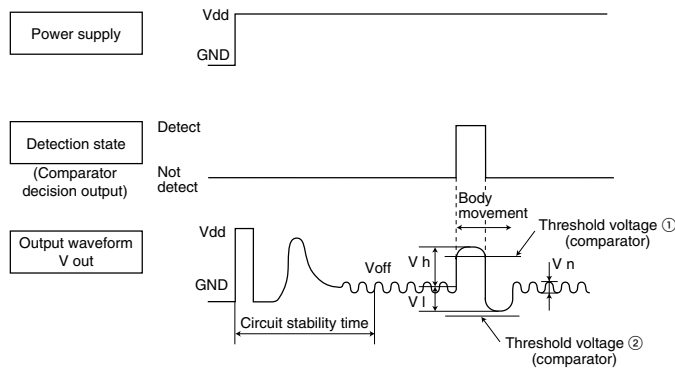

Remark:
Circuit stability time: 45s max.
While the circuitry is stabilizing after the power is turned on, the sensor output is not fixed in the "on" state or "off" state. This is true regardless of whether or not the sensor has detected anything.

MP Motion Sensor (AMN2, 3, 4)

DETECTION PERFORMANCE

1. Standard detection type

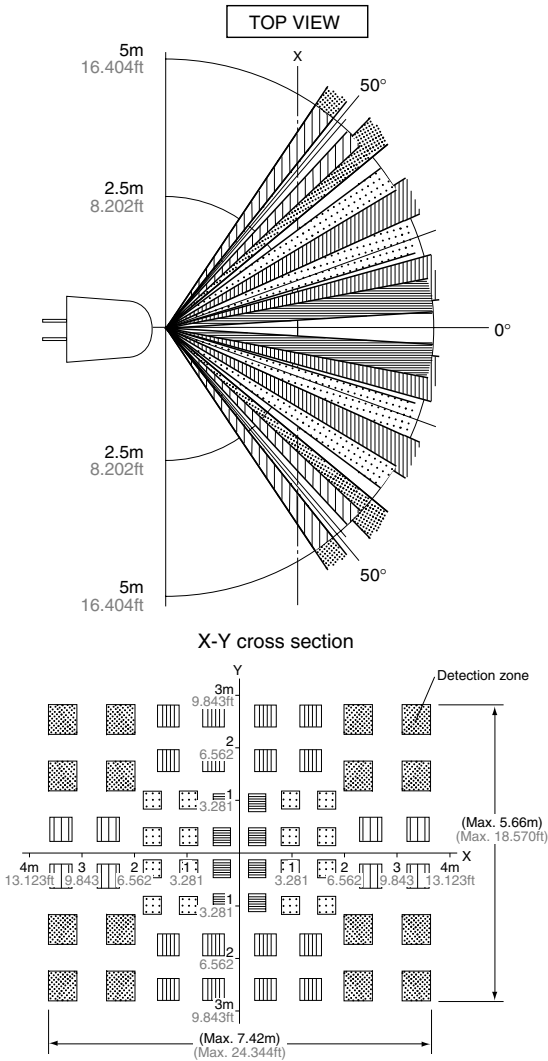

Remarks:

1. The X-Y cross-sectional diagram shows the detection area.
2. The differences in the detection zone patterns are indicative of the projections of the 16 lenses with single focal point and with five optical axes. An object whose temperature differs from the background temperature and which crosses inside the detection zone will be detected.

2. Slight motion detection type

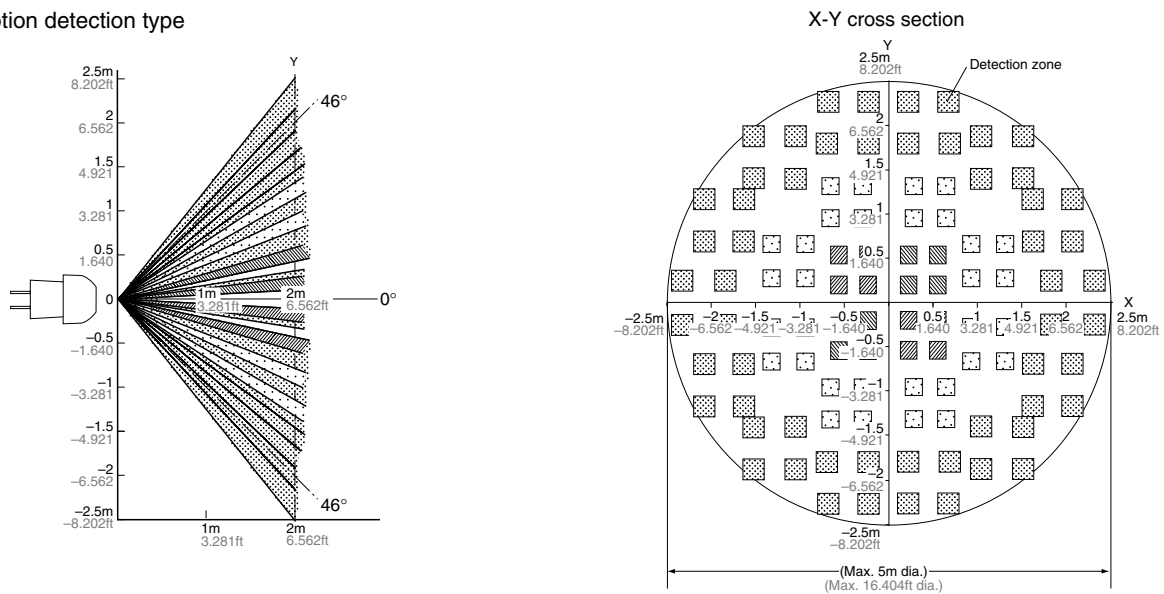

Remarks:

1. The X-Y cross-sectional diagram shows the detection area.
2. The differences in the detection zone patterns are indicative of the projections of the 26 lenses with single focal point and with three optical axes. An object whose

temperature differs from the background temperature and which crosses inside the detection zone will be detected.

3. Spot detection type

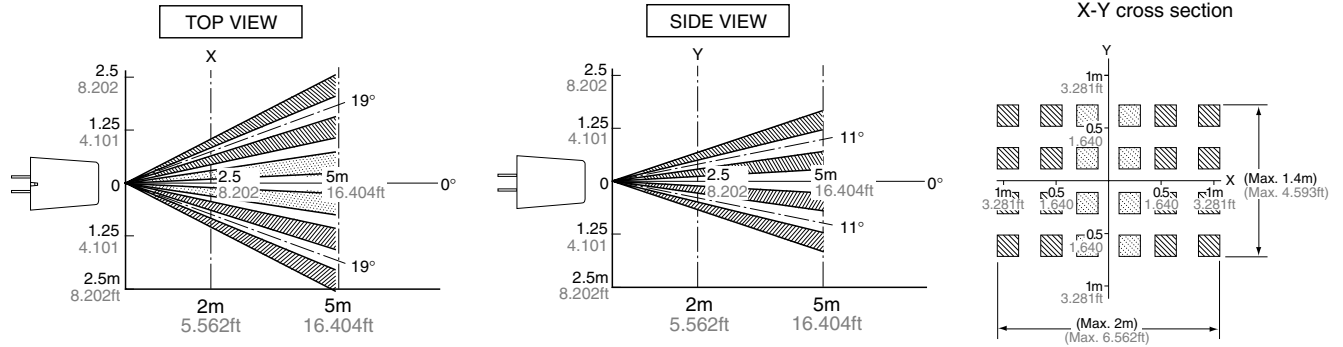

Remarks: 1. The X-Y cross-sectional diagram shows the detection area.
 2. The differences in the detection zone patterns are indicative of the projections of the 6 lenses with single focal point and with two optical axes.
 An object whose temperature differs from the background temperature and which crosses inside the detection zone will be detected.

4. 10m detection type

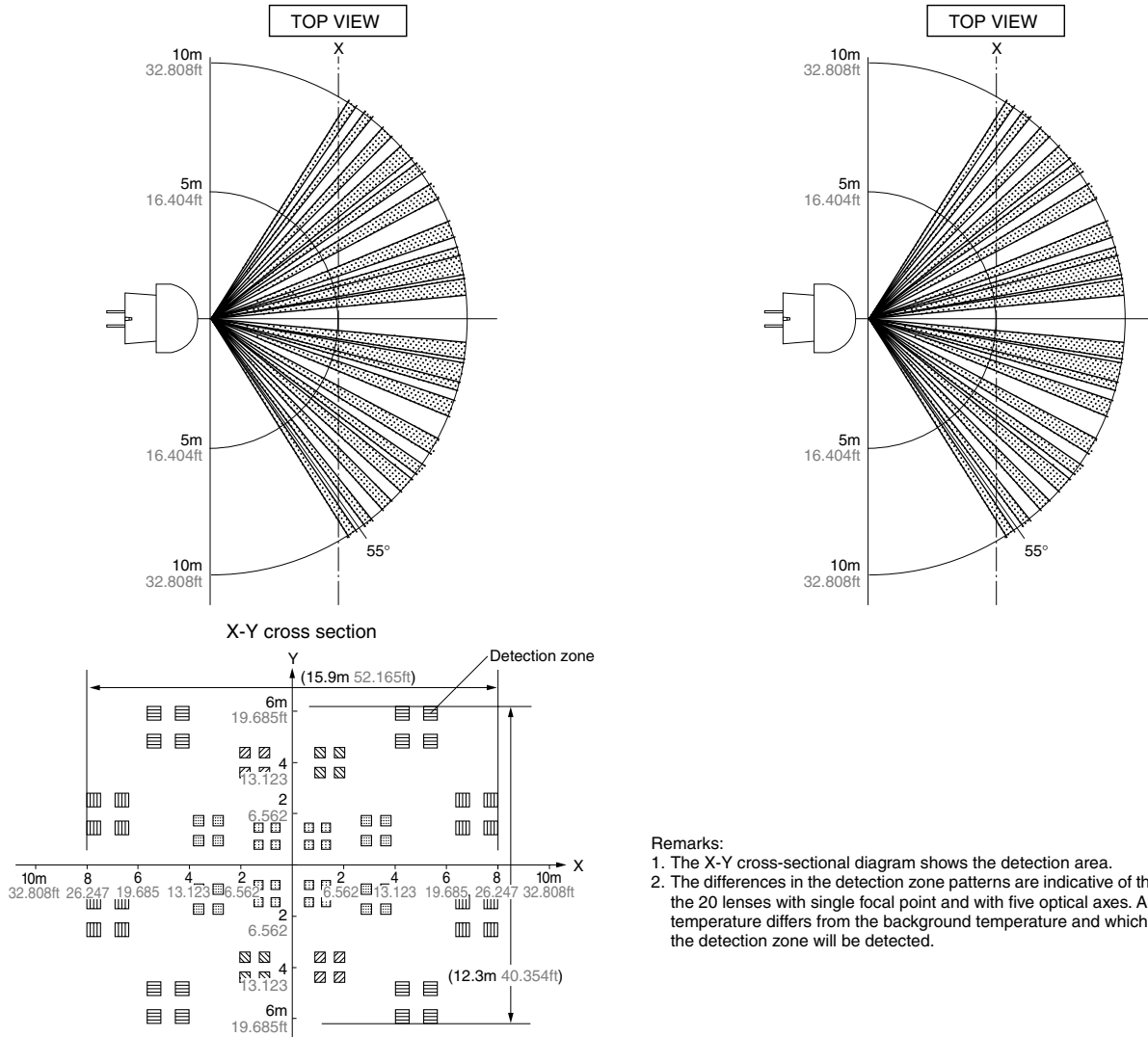

Remarks:
 1. The X-Y cross-sectional diagram shows the detection area.
 2. The differences in the detection zone patterns are indicative of the projections of the 20 lenses with single focal point and with five optical axes. An object whose temperature differs from the background temperature and which crosses inside the detection zone will be detected.

5. Notes regarding the detection zone

The detection zone has the polarity shown in the diagram on the right. When targets enter both the + and - zones with the same timing, the signals are cancelled each other, thus in this case there is a possibility that the object cannot be detected at the maximum specified detection distance.

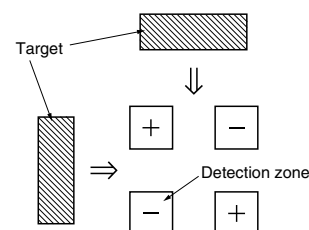

MP Motion Sensor (AMN2, 3, 4)

HOW TO USE

1. Wiring diagram

1) Digital output

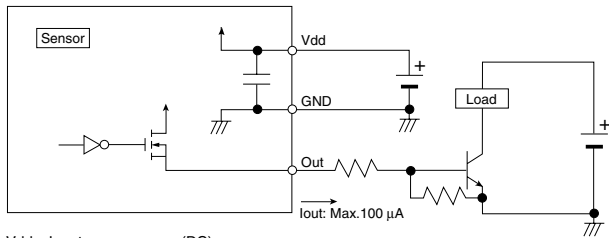

Vdd: Input power source (DC)
 GND: GND
 Out: Output (Comparator)

2) Analog output

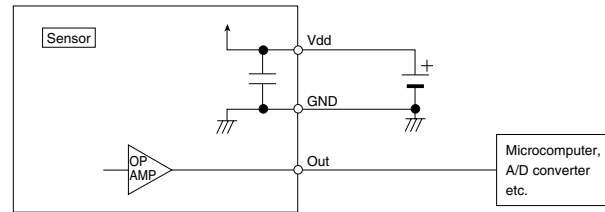

2. Timer circuit example

1) Digital output

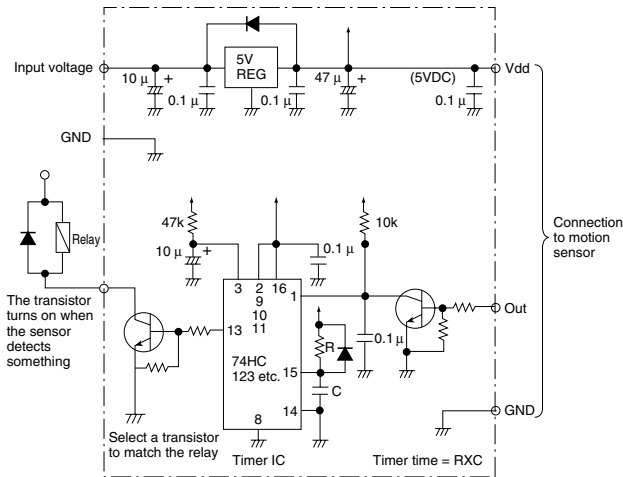

Note: This is the reference circuit which drives the MP motion sensor. Install a noise filter for applications requiring enhanced detection reliability and noise withstanding capability. Differences in the specifications of electronic components to which the units are connected sometimes affect their correct operation; please check the units' performance and reliability for each application.

2) Analog output

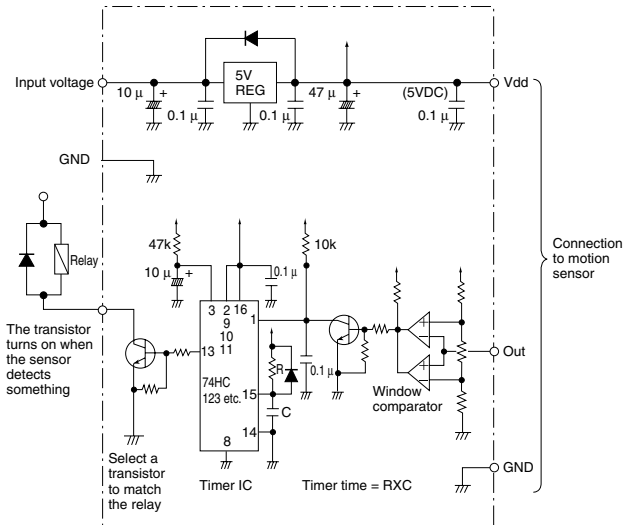

Note: This circuit is a sample of a drive circuit for the MP Motion Sensor. Its noise resistance and long-term reliability are not considered or investigated. To improve the detection reliability and noise resistance of the circuit, consider adding a noise filter. Matsushita Electric Works, Ltd. accepts no responsibility for damages resulting from the use of this circuit.

3. Installation

Install the sensor so that people will be entering from the X or Y direction shown below. If persons approach the sensor from the Z direction, detection distance will be shortened.

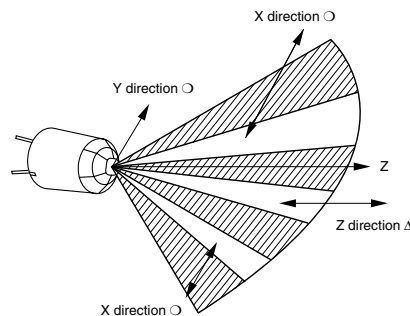

MP Motion Sensor (AMN2, 3, 4)

mm inch General tolerance $\pm 0.5 \pm .020$

DIMENSIONS

1. Standard detection type

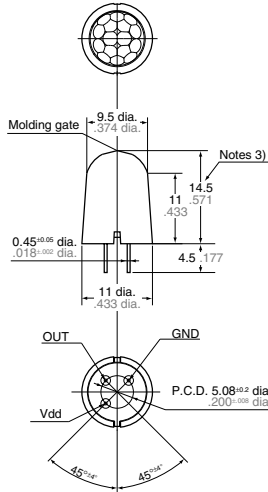

Recommended PC board pattern

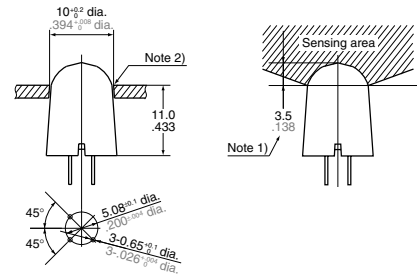

- Notes: 1. In order to ensure proper detection, install it with the lens exposed at least 3.5mm .138inch.
2. As for panel mounting hole, tapering or making a large size hole should be done.
3. The height dimension does not include the remaining molding gate.

2. Slight motion detection type

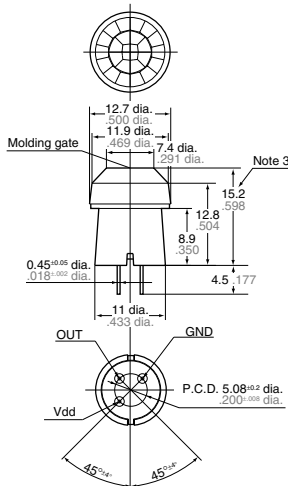

Recommended PC board pattern

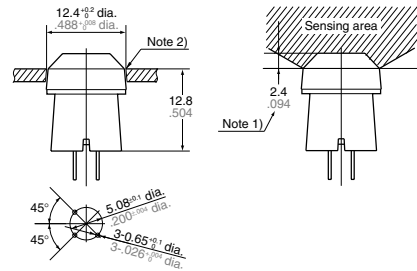

- Notes: 1. In order to ensure proper detection, install it with the lens exposed at least 2.4mm .094inch.
2. As for panel mounting hole, tapering or making a large size hole should be done.
3. The height dimension does not include the remaining molding gate.

3. Spot detection type

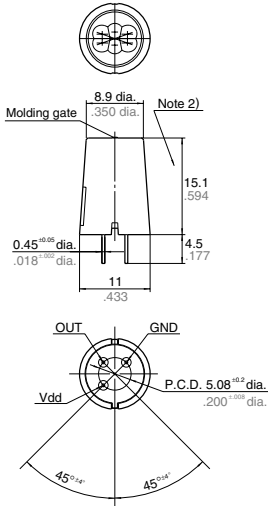

Recommended PC board pattern

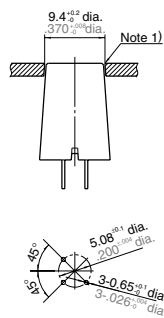

- Notes: 1. As for panel mounting hole, tapering or making a large size hole should be done.
2. The height dimension does not include the remaining molding gate.

4. 10m detection type

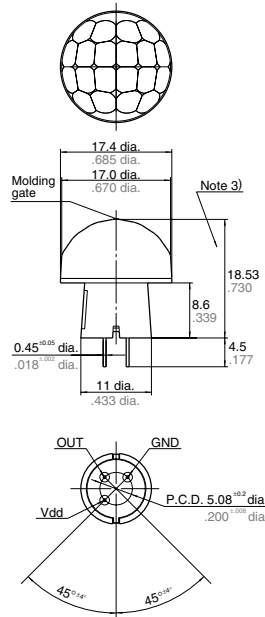

Recommended PC board pattern

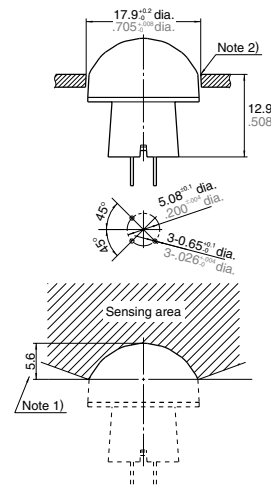

- Notes: 1. In order to ensure proper detection, install it with the lens exposed at least 5.6mm .220inch.
2. As for panel mounting hole, tapering or making a large size hole should be done.
3. The height dimension does not include the remaining molding gate.

MP Motion Sensor (AMN2, 3, 4)

NOTES

1. Checkpoints relating to principle of operation

MP motion sensors are passive infrared sensors which detect changes in the infrared rays. They may fail to detect successfully if a heat source other than a human being is detected or if there are no temperature changes in or movement of a heat source. Care must generally be taken in the following cases. The performance and reliability of the sensors must be checked out under conditions of actual use.

<1> Cases where a heat source other than a human being is detected.

- 1) When a small animal enters the detection range.
- 2) When the sensor is directly exposed to sunlight, a vehicle's headlights, an incandescent light or some other source of far infrared rays.
- 3) When the temperature inside the detection range has changed suddenly due to the entry of cold or warm air from an air-conditioning or heating unit, water vapor from a humidifier, etc.

<2> Cases where it is difficult to detect the heat source

- 1) When an object made of glass, acrylic or other subject which far infrared rays have difficulty passing through is located between the sensor and what is to be detected.
- 2) When the heat source inside the detection range hardly moves or when it moves at high speed; for details on the movement speed, refer to the section on the performance ratings.

2. When the detection area becomes larger

When the difference between the ambient temperature and body temperature is large (more than 20°C 68°F), detection may occur in isolated areas outside the specified detection range.

3. Other handling cautions

- 1) Be careful not to allow dust or dirt to accumulate on the lens as this will adversely affect the detection sensitivity.
- 2) The lens is made of a soft material (polyethylene).
Avoid applying a load or impact since this will deform or scratch the lens, making proper operation impossible and causing a deterioration in its performance.

3) The sensor may be damaged if it is exposed to static with a voltage exceeding $\pm 200V$. Therefore, do not touch its terminals directly, and exercise adequate care in the handling of the sensor.

4) When the leads are to be soldered, solder them by hand for less than 3 seconds at a temperature of less than 350°C 662°F at the tip of the soldering iron. Avoid using a solder bath since this will cause a deterioration in the sensor's performance.

5) Do not attempt to clean the sensor. Cleaning fluid may enter inside the lens area causing a deterioration in performance.

6) When using the sensors with cables, it is recommended that cables which are shielded and as short as possible be used in order to safeguard against the effects of noise.

4. Ambient operating conditions

- 1) Temperature: Refer to the absolute maximum ratings for the temperature of each individual sensor.
- 2) Humidity: 15% to 85% RH (No freezing nor condensation at low temperature)
- 3) Atmospheric pressure: 86 to 106 kPa
- 4) Because the humidity range differs depending on the ambient temperature, the humidity range indicated below should be used. Continuous operation of the switch is possible within this range, but continuous use near the limit of the range should be avoided. This humidity range does not guarantee permanent performance.

<MP Motion Sensor>

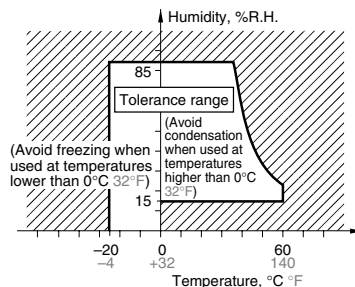

In general, degradation of electronic devices accelerates when they are operated under conditions of high temperature or high humidity. Before use, confirm the reliability of the sensors under the expected operating conditions.

5) When the sensor (especially for ST type) is used in noisy environments, connect a capacitor (approx. 1 μ F) across its power input terminals and sensor output terminals.

6) The sensors do not have a water-proof or dust-proof construction. Depending on the ambient operating conditions, some means of providing protection from water and dust and preventing the formation of ice and condensation must be provided prior to using the sensors. If a sensor is used with a cover installed, the initial detection performance specifications may not be able to be met. Confirm the operation under the actual operating conditions.

7) Take care to avoid exposing the sensors to heat, vibration or impact since malfunctioning may result.

5. Concerning external surge voltages

Since the internal circuitry may be destroyed if an external surge voltages is supplied, provide an element which will absorb the surges. The levels of the voltage surges which the sensor can withstand is given below.

MP motion sensors: Within the supply voltage given in the absolute maximum ratings.

6. Concerning power supply-superimposed noise

Use a regulated power supply as the power supply. Otherwise, power supply-superimposed noise may cause the sensors to malfunction. The levels of noise which the sensor can withstand is given below.

MP motion sensors: $\pm 20 V$ (50ns, 1 μ s wide square waves)

7. Drop damage

If the sensor is dropped, damage can occur resulting in incorrect operation. If dropped, be sure to do a visual check of the exterior for noticeable damage and check the operation characteristics for faulty operation.

8. Concerning the circuit sides

Since the circuit sides given in this catalog are not protected in terms of circuit design, check out the performance and reliability of the circuits prior to using the sensors.

These materials are printed on ECF pulp.
These materials are printed with earth-friendly vegetable-based (soybean oil) ink.



Matsushita Electric Works, Ltd. Automation Controls Business Unit

■ Head Office: 1048, Kadoma, Kadoma-shi, Osaka 571-8686, Japan
Telephone: +81-6-6908-1050
Facsimile: +81-6-6908-5781

COPYRIGHT © 2006 All Rights Reserved
Specifications are subject to change without notice.
ASCT1B324E 200612-0YT