

Dynamic Microphone



Features:

- Frequency response tailored for vocals, with brightened midrange and bass roll off.
- Uniform cardioid pickup pattern isolates the main sound source and minimizes background noise.
- Pneumatic shock-mount system cuts down handling noise.
- Effective, built-in spherical wind and pop filter.
- Supplied with break-resistant stand adapter which rotates 180°.
- Legendary shure quality, ruggedness and reliability.

Overview

The Shure SM58[®] is a unidirectional (cardioid) dynamic vocal microphone designed for professional vocal use in sound reinforcement and studio recording. A highly effective, built-in spherical filter minimizes wind and breath "pop" noise. A cardioid pickup pattern isolates the main sound source while minimizing unwanted background noise. The SM58 has a tailored vocal response for a sound which is a world standard. Rugged construction, a proven shock mount system, and a steel mesh grille ensure that even with rough handling, the SM58 will perform consistently. Outdoors or indoors, singing or speech - the SM58 is the overwhelming choice of professionals worldwide.

Specifications:

Type : Dynamic (moving coil)
Frequency response : 50 to 15,000Hz.

Typical Frequency Response

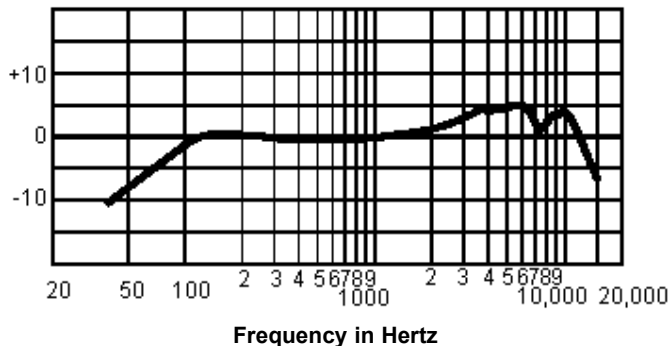

Polar Pattern:

Unidirectional (cardioid), rotationally symmetrical about microphone axis, uniform with frequency.

<http://www.farnell.com>
<http://www.newark.com>
<http://www.cpc.co.uk>



Dynamic Microphone



Typical Polar Patterns

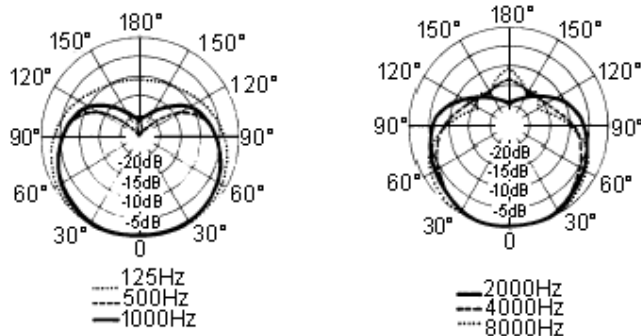

Sensitivity: (At 1000Hz open circuit voltage).

-54.5dBV/Pa (1.85mV).

1Pa = 94dB SPL.

Impedance:

Rated impedance is 150 Ω (300 Ω actual) for connection to microphone inputs rated low impedance.

Polarity:

Positive pressure on diaphragm produces positive voltage on pin 2 with respect to pin 3.

Internal Connections

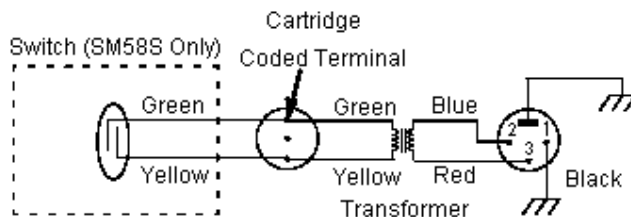

Connector:

Three-pin professional audio connector (male XLR type).

Case:

Dark grey, enamel-painted, die cast metal, matte-finished, silver coloured, spherical steel mesh grille.

Dynamic Microphone



Overall Dimensions

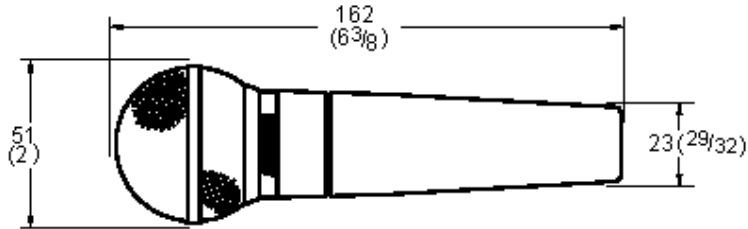

Dimensions : Millimetres (Inches)

Swivel Adapter:

Positive-action, break-resistant, adjustable through 180°, with standard 5/8 inches to 27 thread.

Part Number Table

Description	Part Number
Shure Microphone	MP33511

Disclaimer This data sheet and its contents (the "Information") belong to the Premier Farnell Group (the "Group") or are licensed to it. No licence is granted for the use of it other than for information purposes in connection with the products to which it relates. No licence of any intellectual property rights is granted. The Information is subject to change without notice and replaces all data sheets previously supplied. The Information supplied is believed to be accurate but the Group assumes no responsibility for its accuracy or completeness, any error in or omission from it or for any use made of it. Users of this data sheet should check for themselves the Information and the suitability of the products for their purpose and not make any assumptions based on information included or omitted. Liability for loss or damage resulting from any reliance on the Information or use of it (including liability resulting from negligence or where the Group was aware of the possibility of such loss or damage arising) is excluded. This will not operate to limit or restrict the Group's liability for death or personal injury resulting from its negligence. SPC pro-SIGNAL is the registered trademark of the Group. © Premier Farnell plc 2009.

<http://www.farnell.com>
<http://www.newark.com>
<http://www.cpc.co.uk>

