

THIS DOCUMENT CONTAINS DATA PROPRIETARY TO PROJECTS UNLIMITED, INC. ANY USE OR REPRODUCTION, IN ANY FORM, WITHOUT PRIOR WRITTEN PERMISSION OF PROJECTS UNLIMITED, INC. IS PROHIBITED.  
© 2003, Projects Unlimited Inc.

SPECIFICATIONS

| PARAMETERS                  | VALUES         | UNITS |
|-----------------------------|----------------|-------|
| RATED VOLTAGE (SQUARE WAVE) | 12             | Vp-p  |
| OPERATING VOLTAGE RANGE     | 3 ~ 18         | Vp-p  |
| RATED CURRENT (MAX)         | 8              | mA    |
| CAPACITANCE                 | 11,000±30%     | pF    |
| MINIMUM SPL @ 10 CM         | 90             | dBA   |
| RESONANT FREQUENCY          | 3,600±500      | Hz    |
| OPERATING TEMPERATURE       | -20 ~ +60      | °C    |
| STORAGE TEMPERATURE         | -30 ~ +70      | °C    |
| HOUSING MATERIAL            | ABS            | -     |
| TERMINAL MATERIAL           | TIN-PLATED PBW | -     |
| WEIGHT                      | 3.8            | grams |

| REVISIONS |                           |         |          |
|-----------|---------------------------|---------|----------|
| LTR       | DESCRIPTION               | DATE    | APPROVED |
| -         | RELEASED FROM ENGINEERING | 4/16/02 |          |
| A         | REVISED TO NEW TEMPLATE   | 6/15/04 | R. W.    |
| B         | ADDED NOTE 3              | 4/29/05 | R. W.    |

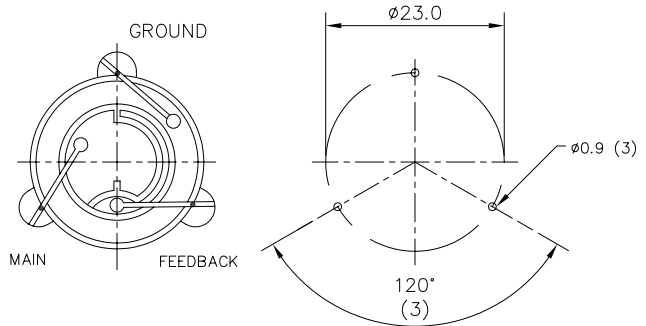
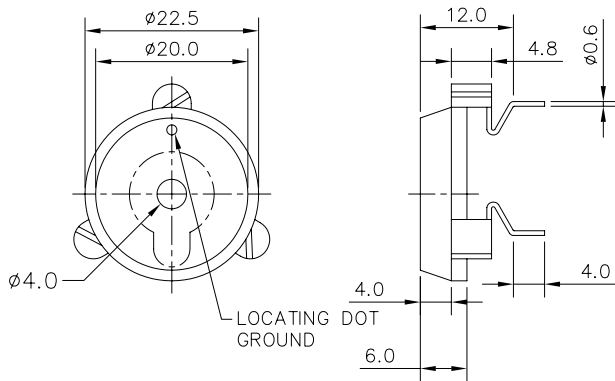
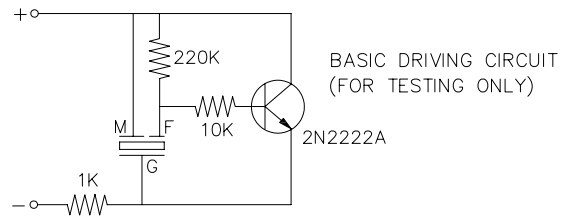

NOTES:

- ALL DIMENSIONS ARE IN MILLIMETERS.
- SPECIFICATION SUBJECT TO CHANGE OR WITHDRAWAL WITHOUT NOTICE.
- PART WASHABLE USING DEIONIZED WATER, OR PURE ISOPROPYL ALCOHOL.

FILE NAME  
AT-24.DWG

|   |  |  |                      |
|---|--|--|----------------------|
| UNLESS OTHERWISE SPECIFIED:<br>DIMENSIONS ARE IN MILLIMETERS. TOLERANCES ARE ±0.5 AND ANGLES ARE ±3°. |  | <b>projects® unlimited</b><br>Dayton, Ohio |                      |
| APPROVALS<br>DRAWN <i>RABL</i> 4/02<br>APPROVED <i>S.J.</i> 4/02                                      |  | TRANSDUCER(ELECTRO-MECH)<br>AT-24          |                      |
| DO NOT SCALE DRAWING  |  | SIZE<br>A                                  | DRAWING NO.<br>AT-24 |
|   |  | SCALE: N.T.S.                              | SHEET 1 OF 1         |