

THIS DOCUMENT CONTAINS DATA PROPRIETARY TO PROJECTS UNLIMITED, INC. ANY USE OR REPRODUCTION, IN ANY FORM, WITHOUT PRIOR WRITTEN PERMISSION OF PROJECTS UNLIMITED, INC. IS PROHIBITED.
© 2003, Projects Unlimited Inc.

SPECIFICATIONS

| PARAMETERS | VALUES | UNITS |
|-----------------------------|---------------------------|-------|
| RATED VOLTAGE (SQUARE WAVE) | 12 | Vp-p |
| OPERATING VOLTAGE RANGE | 3 ~ 28 | Vp-p |
| RATED CURRENT (MAX) | 8 | mA |
| CAPACITANCE | 20,000±30% | pF |
| MINIMUM SPL @ 10 CM | 93 | dBA |
| RESONANT FREQUENCY | 3,000±500 | Hz |
| OPERATING TEMPERATURE | -30 ~ +80 | °C |
| STORAGE TEMPERATURE | -40 ~ +80 | °C |
| HOUSING MATERIAL | ABS | - |
| TERMINAL MATERIAL | Au PLATED PHOSPHER BRONZE | - |
| WEIGHT | 3.7 | grams |

| REVISIONS | | | |
|-----------|------------------------------------|----------|----------|
| LTR | DESCRIPTION | DATE | APPROVED |
| - | RELEASED FROM ENGINEERING | 10/1/01 | |
| A | ADDED HOUSING & PIN MATERIAL | 3/6/02 | S.J. |
| B | REVISED TO NEW TEMPLATE | 6/15/04 | R.W. |
| C | REVISED DIMENSIONS & ADDED NOTE 3 | 1/31/05 | R.W. |
| D | REVISED DIMENSION & REVISED NOTE 3 | 2/11/05 | R.W. |
| E | REVISED TERMINAL MATERIAL | 9/14/05 | B.R. |
| F | REVISED DIMENSION SIZE AND STYLE | 11/29/05 | B.R. |

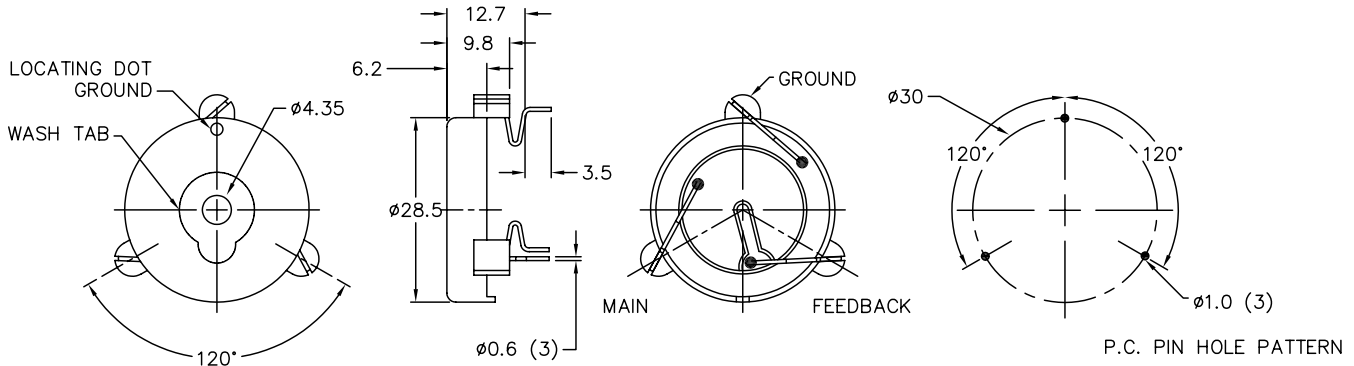
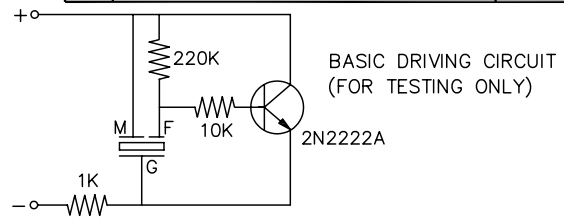

NOTES:

1. ALL DIMENSIONS ARE IN MILLIMETERS.
2. SPECIFICATION SUBJECT TO CHANGE OR WITHDRAWAL WITHOUT NOTICE.
3. PART WASHABLE USING DEIONIZED WATER, OR PURE ISOPROPYL ALCOHOL.

FILE NAME
AT-23.DWG

| UNLESS OTHERWISE SPECIFIED: DIMENSIONS ARE IN MILLIMETERS; TOLERANCES ARE ±0.5 AND ANGLES ARE ±3°. | | projects® unlimited Dayton, Ohio | | | | | | | |
|--|-------|---|----------------------|-------------------|-------|----------------------|-------|-----------------------------|--|
| <table border="1"> <thead> <tr> <th>APPROVALS</th> <th>DATE</th> </tr> </thead> <tbody> <tr> <td>DRAWN <i>RABL</i></td> <td>10/01</td> </tr> <tr> <td>APPROVED <i>S.J.</i></td> <td>10/01</td> </tr> </tbody> </table> | | APPROVALS | DATE | DRAWN <i>RABL</i> | 10/01 | APPROVED <i>S.J.</i> | 10/01 | TRANSDUCER (PIEZO) AT-23 | |
| APPROVALS | DATE | | | | | | | | |
| DRAWN <i>RABL</i> | 10/01 | | | | | | | | |
| APPROVED <i>S.J.</i> | 10/01 | | | | | | | | |
| DO NOT SCALE DRAWING | | SIZE A | DRAWING NO. AT-23 | | | | | | |
| | | SCALE: N.T.S. | SHEET 1 OF 1 | | | | | | |