

Piezo Buzzer

Piezo Transducer (External Circuitry Type)
Vertical Mounting Type

Shape

KPEG502



Rated Voltage (Vp-p)	MAX.30
Current Consumption (mA)	MAX.10@ 10Vp-p,square wave,3.3KHz
Sound Pressure Level (dB)	MIN.93dB@ 10cm/10Vp-p square wave,3.3KHz
Electrostatic Capacity(pF)	25,000±30%@ 120Hz/1V
Operating Temperature (°C)	-30 ~ +85
Operating Temperature (°C)	-40 ~ +95
Weight (Gram)	1.0
Material	PBT+30%Glass UL94V-0(Black)

.:Dimension

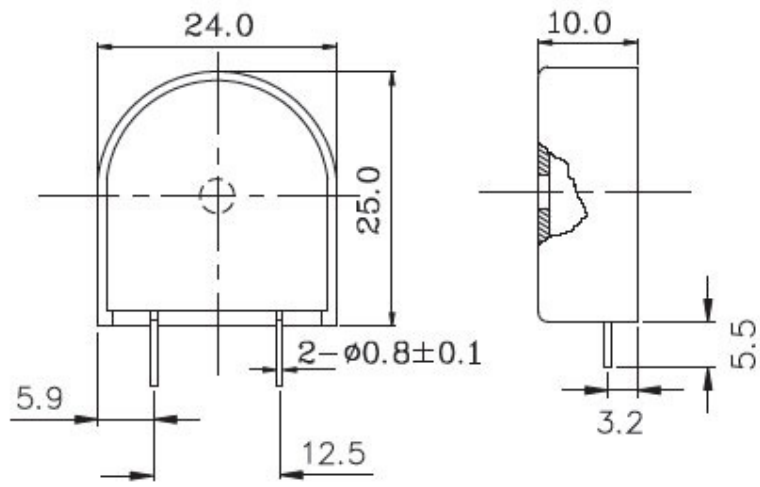

Tol : ± 0.5 Unit : mm

.:Characteristic / Schematic Diagram

