

# bright washers

normal diameter  
for ISO Metric fasteners

Blanke Unterlegscheiben, Normaldurchmesser.  
Type für metrische ISO - Befestigungselemente.  
Rondelles fini brillant, Diamètre normal.  
Modèle moyen pour visserie métrique ISO.

# BS 4320 table forms A & B

Form A. Equivalent to DIN 125.

Form A entspricht DIN 125.

Form A est l'équivalent de DIN 125.

Dimensions in mm.  
Maße in mm.  
Dimensions en millimètres

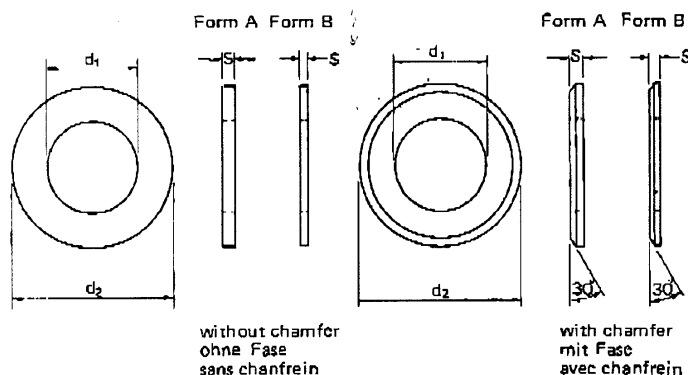

Sizes marked \* are non-preferred.  
Tolerances according to DIN 522

Mit \* bezeichnete Größen sind Sondergrößen  
Toleranzen nach DIN 522

Grandeurs indiquées \* non-prioritaires.  
Tolérances selon DIN 522

Nominal size of bolt or screw	d <sub>1</sub>	d <sub>2</sub>	FORM A		FORM B	
			S	Weight in steel kg/1000 pieces	S	Weight in steel kg/1000 pieces
M1.0	1.1	2.5	0.3	0.009	—	—
M1.2	1.3	3.0	0.3	0.013	—	—
M1.4*	1.5	3.0	0.3	0.012	—	—
M1.6	1.7	4.0	0.3	0.024	—	—
M2.0	2.2	5.0	0.3	0.037	—	—
M2.2*	2.4	5.0	0.5	0.061	—	—
M2.5	2.7	6.5	0.5	0.108	—	—
M3	3.2	7	0.5	0.120	—	—
M3.5*	3.7	7	0.5	0.106	—	—
M4	4.3	9	0.8	0.308	—	—
M4.5*	4.8	9	0.8	0.285	—	—
M5	5.3	10	1.0	0.443	—	—
M6	6.4	12.5	1.6	1.14	0.8	0.587
M7*	7.4	14	1.6	1.39	0.8	0.696
M8	8.4	17	1.6	2.14	1.0	1.33
M10	10.5	21	2.0	4.08	1.25	2.54
M12	13.0	24	2.5	6.27	1.6	4.01
M14*	15.0	28	2.5	8.60	1.6	5.51
M16	17.0	30	3.0	11.3	2.0	7.65
M18*	19.0	34	3.0	14.7	2.0	9.81
M20	21	37	3.0	17.2	2.0	11.5
M22*	23	39	3.0	18.4	2.0	12.3
M24	25	44	4.0	32.3	2.5	20.1
M27*	28	50	4.0	42.3	2.5	26.3
M30	31	56	4.0	53.6	2.5	33.4
M33*	34	60	5.0	75.4	3.0	45.1
M36	37	66	6.0	92.0	3.0	55.1

Materials: Hard bright cold rolled mild steel  
Hard bright brass  
or to buyer's requirements.

Finishes: Self finish, Electro Zinc, Cadmium,  
Nickel or to buyer's requirements.

Werkstoffe: Gehärteter, blanker, kaltewaltzer  
Flußstahl. Gehärtetes  
Blankmessing, oder nach  
Kundenanforderung.

Ausführung: Ohne Oberflächenbehandlung,  
galvanisch verzinkt, kadmiert,  
vernickelt oder nach  
Kundenanforderungen.

Matières: Acier doux laminé à froid  
brillant corroyé, laiton dur  
brillant ou selon exigences  
Client.

Finition: Uni, traitement galvanique, Zn,  
Cd, Ni, ou selon exigences Client.



W. J. Wild Manufacturing Co.  
Floodgate Street  
Birmingham B5 5SJ  
telephone 021-643 9611 (16 lines)  
telegrams Presscycal B'ham  
telex 338177

sheet  
1