



ENGINEERING BULLETIN

June 1971

Bulletin No. 6

NSF ROTARY WAFER SWITCHES Models JKM and JKB

J TYPE MECHANISM
(KM & KB WATER ABSOLUTE)

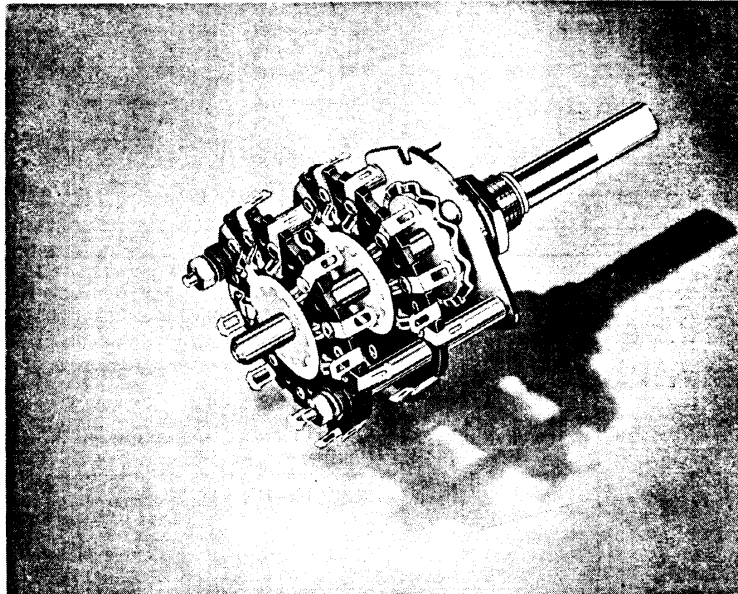

These switches provide up to 22 contact positions on a single section without need for insulated back contacts. Used in multi-bank form they will meet the most complicated circuit requirements in present day radio, television, instrument and electronic designs. They are suitable for inclusion in Tape Recorder Decks and sections only can be supplied if required.

ELECTRICAL CHARACTERISTICS

Maximum Working Voltage :		300v. A.C./D.C.
Proof Voltage :		1000v R.M.S.
Contact Rating:	150 m.a. at	} Resistive Load
	50 m.a. at	
	500 m.a. at	
Current carrying capacity :		250v. R.M.S. Non-Reactiive Load
(not breaking)		250v. D.C.
Contact Resistance :		30v. D.C or A.C. } 5 amps.
		Less than 3 milliohms.

MAXIMUM SWITCHING.

1 pole	2 to 12 positions.
2 poles	2 to 9 positions.
3 poles	2 to 5 positions.
4 poles	2 to 4 positions.
5 poles	2 to 3 positions.
6 poles	2 positions.

ADJUSTABLE STOPS

Normally the anti-clockwise stop is supplied fixed and an adjustable stop, to act in any clockwise position, has been available to order. Both stops are now available to order in adjustable form, thus rotation can be restricted between any selected positions.

CONTACTS.

Clips : Spring brass silver plated. Spring quality silver alloy clips are available at additional cost.
Rotor Blades : Hard brass heavily silver plated.

INDEX MECHANISMS.

Single ball bearing location with index spring of special quality spring steel. Available with 30° or 60° indexing. Approximate torque, mechanism only, with standard spring, 15 to 25ozs. Springs to meet other torque requirements are available to order. If heavy duty indexing is required, the N.S.F. type "HDI" cam and roller mechanism, as described in Bulletin No. 11, can be supplied.

DUAL CONCENTRIC SHAFTS

Now available to order. Possible uses, two switches in one frame or similar applications. Switches can also be supplied with hollow shafts to allow of driving another device by a 1/8" shaft concentric with the switch shaft.

Continued overleaf

INSULATION.

Stators and Rotors: Highest grades of punching quality S.R.B.P. materials to B.S. 2076 Grade L. Tropical grade material to B.S. 2076 grade H is available at extra cost, if desired.

FINISH.

Standard : All ferrous parts plated ; non-ferrous parts clean.
Special : Special finishes to withstand tropical conditions are available when specified.

MOUNTING DETAILS.

Unless otherwise specified, each switch is supplied with one fixing nut $\frac{3}{8}$ " thick, .525" across flats, threaded $\frac{3}{8}$ " x 32 T.P.I. Whitworth form and one $\frac{3}{8}$ " internal tooth steel lock-washer. Various methods of mounting may be provided to meet customers' special requirements. Panel and spindle sealing is available if required.

CONSTRUCTION.

The switch sections are spaced by tubular metal spacers and held in place with a positive relationship to the index mechanism assembly by side strut screws.

STANDARD CONTACT ARRANGEMENTS.

Please refer to Engineering Bulletin No. 7 for details of standard contact arrangements and use these whenever possible.

MAIN SWITCHES

JKM only. — Switches, rated at 1 amp., 250 volt, A.C. or D.C., are available in SPST, DPST, SPDT, or 3-way (making 3 contacts when thrown). A.C. switches are attached to end of shaft and may be arranged to operate at any given position through the rotation of the switch.

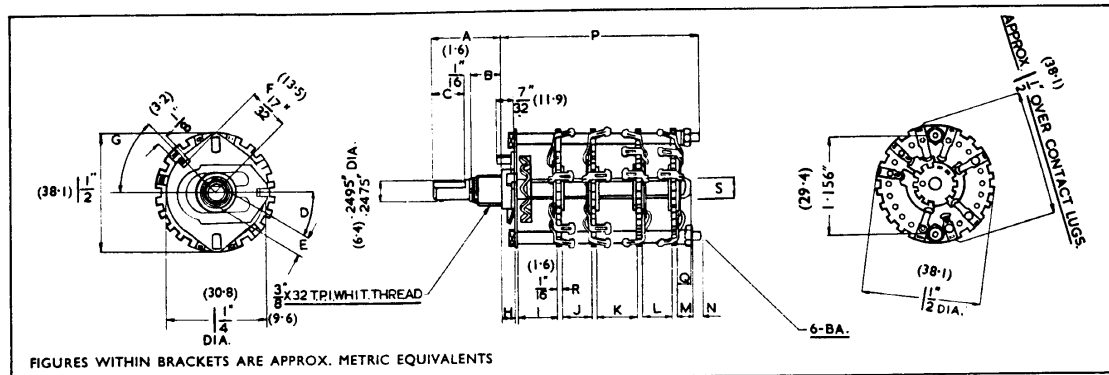

KEY TO DIMENSIONAL DIAGRAM.

- A. Shaft length : Optional $\pm \frac{1}{4}$ ". Diameter : .2475" —.2495" (after plating).
 - B. Bushing Thread length : Standard $\frac{1}{4}$ " or $\frac{3}{8}$ ". Special lengths if necessary. Threads $\frac{3}{8}$ " x 32 T.P.I. Whitworth form.
 - C. Flat length : Standard not more than $\frac{5}{8}$ ", in no case closer than $\frac{1}{8}$ " to end of bushing. Tolerance $\pm \frac{1}{64}$ ". Special shaft terminations may be provided to meet customers' particular requirements.
 - D. Angle of flat : as desired $\pm 2^\circ$. Specify position of switch in which flat is shown—fully counter clockwise is preferred.
 - E. Flat thickness : Standard .195" $\pm .005$ " for grub screws, .195" $\pm .002$ " for push-on knobs.
 - F. Distance of locating lug from centre of shaft (centre line to centre line) $\frac{17}{32}$ ". Alternative, $\frac{3}{8}$ ".
 - G. Angles available, $\frac{17}{32}$ " lug: $0^\circ, 45^\circ, 135^\circ, 180^\circ, 225^\circ, 315^\circ$. With $\frac{3}{8}$ " lug, angles as above plus 15° or 195° .
 - H. Bushing shoulder : Standard $\frac{3}{8}$ " ($\frac{7}{32}$ " if sealed bush specified). Special lengths provided above this dimension where required.
 - I. First Spacer : $\frac{1}{4}$ " min. with lugs facing front* of first section. $\frac{7}{16}$ " min. with lugs facing rear of first section. May be any length (within switch limitations) over these min. dimensions.
 - J-K-L. Spacers : $\frac{7}{16}$ " min. with lugs facing each other ; $\frac{1}{4}$ " min. with lugs facing same direction as adjoining sections ; $\frac{3}{8}$ " min. with lugs facing away from each other. No max. limit (within switch limitations.)
 - M. If no spacer, $\frac{1}{8}$ " min. any length spacer desired may be inserted at this point ; $\frac{1}{8}$ " Standard.
 - N. Thread extension : $\frac{1}{8}$ "—6BA., any length desired.
 - P. Specify maximum overall length, if important.
 - Q. Shaft extension at rear : nominal $\frac{1}{8}$ " to $\frac{1}{4}$ " Dimensions (after plating) ; dia. .2475"/.2495" ; across flats .187"/.188" (4-8)
 - R. Standard $\frac{1}{8}$ " bakelite sections.
 - S. Rear Shaft Dimensions, JKM: Dia. 0.250"(6.4); across flats, 0.181" (4.0); JKB: Dia. 0.187" (4.0); across flats, 0.125" (3.2).
- ROTOR BLADES :** Standard switches are made before break "shorting" type in which connection is maintained with one contact until after the next contact is made. Break before make "non-shorting" switches, which break connection with one contact before the next contact is made, are available to order.
**"Front" is when switch viewed from the knob end.

N. S. F. LIMITED

HEAD OFFICE:
KEIGHLEY, YORKSHIRE. BD21 5EF
Telephone: Keighley 05352-61144 Telex: 51270
Telegrams: ENESEF Telex Keighley

MU INDEXING
MA WAFERS

Engineering Bulletin No.29

Rotary Wafer switch - model MU-MK.

General Information These switches have 32mm (1.26") diameter moulded wafers with 22 contact positions providing up to 12 switching positions. The stators are moulded from glass fibre loaded diallylphthalate. Optional features include concentric shafts, panel and spindle seals and rigid termination's for printed circuit connections.

Characteristics. Electrical, Maximum working voltage 300Vac/dc.

Contact rating,
 Current carrying 5amp continuous.
 Current breaking with a resistive/non-reactive load.
 60mA at 250Vdc.
 150mA at 250Vac (rms).
 500mA at 30Vac/dc (rms).

Proof Voltage. 1000Vrms at sea level.
 Insulation resistance. Not less than 2 Gohms.
 (between any 2 parts requiring electrical insulation)

Contact resistance (initial). 10 milliohms maximum.
 100mA. max.

Maximum Switching.

No. of Poles.	30° MU-MK		
	1 Pole.	2 to 12 ways	5 Pole.
2 Pole.	2 to 9 ways	6 Pole.	2 ways
3 Pole.	2 to 5 ways	7 Pole.	2 ways
4 Pole.	2 to 4 ways		

Standard Contact Arrangements.

Please refer to Engineering Bulletins RW25a for details of standard contact arrangements and use these whenever possible.

Index Mechanism.

The preferred mechanism used with the MK wafers is the Type MU providing indexing angles of 30°, 45° and 60°, (see Bulletin RW36 for full technical details). Torque ranges available are:-

Light 7 to 14 x 10⁻² Nm (10 to 20 oz, ins,) Medium 14 to 28 x 10⁻² Nm (20 to 40 oz, ins,)
 High 28 to 35 x 10⁻² Nm (40 to 50 oz, ins,)

Other mechanisms which may be used as alternatives are:-

Heavy Duty (Bulletin RW11) when torque in excess of 0,35 Nm up to 0.63Nm (90 oz.in.) is required or where locating pins are preferred to lugs, on 15,1mm (0.6") radius.

Type 'U' (Bulletin RW27) when torque values up to 0.49Nm (70 oz.in.) are required.

Type 'J' (Part of Bulletin RW 6) where additional locating lug angles of 0°, or 180° are specified, also where radius of 13,5mm (0.53") is required.

Contacts & Termination's.

Standard. - Silver plated brass.
 Alternatives. - Hard gold plated or silver alloy contacts are available at extra cost as are contacts with gold flash.
 Termination's. - Forward, standard: Straight, alternative.

Rotor Blades.

Standard . - Shorting. (make before break. MBB.)
 Alternative. - Non-shorting. (break before make. BBM.)

Insulation.

Stator. - Moulded glass fibre loaded diallylphthalate (DAP)
 Rotor. - Polycarbonate.

Finish.

Index Springs, Stainless steel: other metal parts, passivated zinc plated. Finishes to order.

Mounting Details.

Imperial (standard).	Metric (alternative)
Bush 3/8" x 32TPI (Whit.)	M10 x 0.75.
Shaft 0.25" dia.	6mm, dia.
Nut 0.525" A/F.	14mm A/F.

The alternative is optional in each case.
 Unless otherwise specified, each switch is supplied with an internal tooth steel lock washer.

Construction.

The switch wafers are spaced by tubular metal spacers and held in place, with a positive relationship to the index mechanism, by side strut screws.

Alternative Shafts.

Concentric shafts - dual concentric shafts and mechanisms for dual switching applications, also with hollow independent drive of other devices by 1/8" concentric shaft.

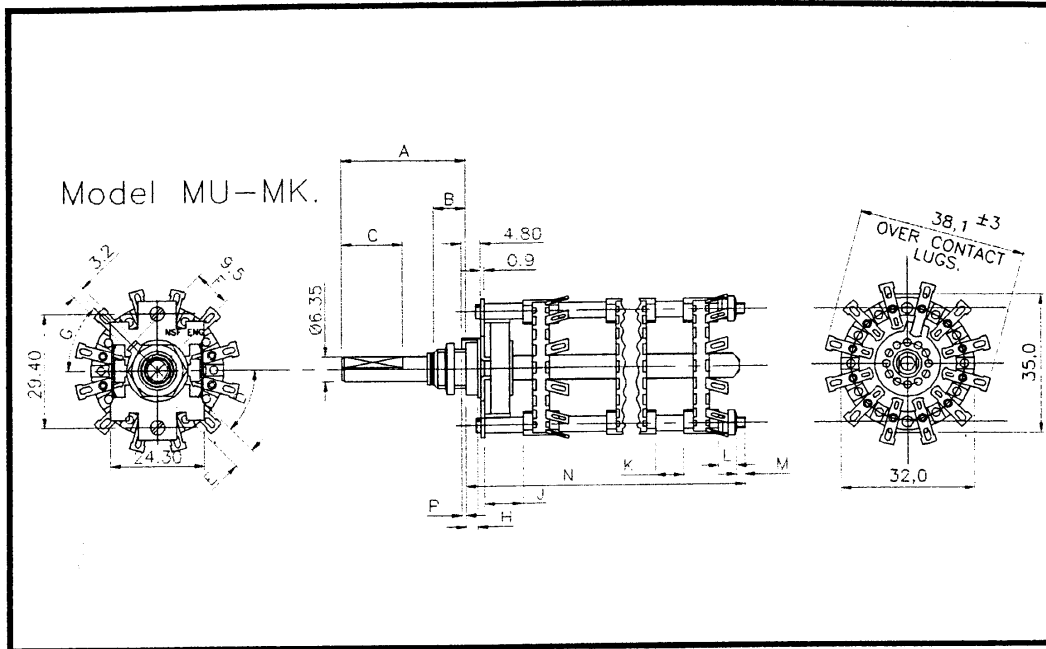

DIMENSIONS ARE IN MILLIMETRES.

Key to Details.

- | | |
|--|---|
| <p>A. Shaft length: optional ± 0.40 (0.016")</p> <p>B. Bushing thread length: preferred standard 9.5 (0.375"); 6.35 (0.250") available as an alternative. Special lengths if necessary</p> <p>C. Flat length: length to specification. Tolerance ± 0.40 (0.016"). Special shaft termination's may be provided to special requirements.</p> <p>D. Angle of flat: to specification $\pm 2^\circ$; specify position of flat, with switch shaft in fully anti-clockwise position when viewed from front or knob end.</p> <p>E. Flat thickness: standard 5.55 ± 0.15 (0.218" ± 0.005") for grub screws; 4.95 ± 0.05 (0.195" ± 0.002") for push-on knobs.</p> <p>F. Distance of locating lug from shaft, centre line to centre line.</p> <p>G. Angle of locating lug: type MU mechanism; $45^\circ, 135^\circ, 225^\circ$ and 315° from horizontal centre line; type A mechanism also includes 0° and 180° as viewed.</p> | <p>H. Bushing shoulder, standard 3.2 (0.125")</p> <p>J. Front spacer, minimum dimension: MU-MA 9.5 (0.375"), A-MA 4.8 (0.187").</p> <p>K. Other spacers: minimum dimensions.
Clips facing same direction NIL.
Clips facing away or flat clips NIL.
Clips facing each other 3.2 (0.125")</p> <p>L. If no spacer 2.4 (0.093"). Any length spacer desired may be inserted at this point.</p> <p>M. Thread extension: 1/8"(min) x M2 x 0.4 any length desired.</p> <p>P. Standard locating lug lengths:
MU-MA,
unsealed, projects 1.6 (0.062") beyond mounting face;
sealed, 0.05/0.15 (0.002"/0.006") below mounting face;
A-MA,
projects 4.8 (0.187") beyond mounting face.</p> |
|--|---|

Revised May 1999.

© NSF Controls Limited.

General Information These versatile miniature switches have 25.4 mm diameter moulded wafers and are available in 2 versions, 36° indexing - having 18 clip positions and 30° indexing - having 22 such positions. 15°, 45° and 60° indexing are variations of the latter. Optional features include concentric shafts, panel and spindle seals, printed circuit termination's and momentary contact models.

Characteristics. Electrical, Maximum working voltage, 300Vdc/ac (rms).
 Contact rating, Current carrying 2amp continuous.
 Current breaking with a resistive/non-reactive load. 50mA at 300Vdc/ac (rms).
 500mA at 30Vdc/ac (rms).
 Proof Voltage. 1000Vrms at sea level.
 Insulation resistance. Not less than 500 megohms at 500Vdc.
 (between any 2 parts requiring electrical insulation)
 Contact resistance (initial). 10 milliohms maximum at 100mV (rms). 100mA.max.
 Mechanical.
 End stop strength. 0,8 ± 0,1 Nm (114oz.in.)
 Temperature range. -40°C. to +100°C.

Maximum Switching.

No. of Poles.	36° MU-MA (b)	30° MU-MA (a)	45° MU-MA (c)	60° MU-MA (d)	15° MU-MG
	10 Positions.	12 Positions.			2 wafers
1 Pole.	2 to 10 ways	2 to 12 ways	2 to 8 ways	2 to 6 ways	providing 1 pole
2 Pole.	2 to 5 ways	2 to 7 ways	(fixed stop at	2 to 6 ways	24 way
3 Pole.	2 to 4 ways	2 to 5 ways	positions 3, 5,	2 or 3 ways	switching.
4 Pole.	2 or 3 ways	2 to 4 ways	and 7 ways)	2 or 3 ways	
5 Pole.	-	2 to 3 ways		2 ways only	
6 Pole.	-	2 ways only		on-off	
7 Pole.	-	2 ways only		-	

Standard Contact Arrangements.

Please refer to Engineering Bulletins RW25a (30° and 45°) or RW25b (36°) for details of standard contact arrangements and use these whenever possible.

Index Mechanism.

The Type MU mechanism provides indexing angles of 30°, 36°, 45° and 60°, (see Bulletin RW36 for full technical details). The low friction moulded cam followers in the assembly ensures a smooth indexing action. Balance pressure springs provide consistent and readily reproducible total switch torque values within the following ranges.

Light 7 to 18 x 10⁻² Nm (10 to 26 oz, ins.) Medium 14 to 32 x 10⁻² Nm (20 to 46 oz, ins.)
 High 28 to 56 x 10⁻² Nm (40 to 80 oz, ins.)

Type A indexing mechanism may also be used as an alternative where a simpler, space saving mechanism is required. The switch then becomes model A-MA. 30° indexing only.

Contacts & Termination's.

Standard. - Silver plated brass.
 Alternatives. - Hard gold plated or silver contacts are available at extra cost as are contacts with gold flash.
 Termination's. - Forward, standard: Straight, alternative.

Rotor Blades.

Standard. - Shorting. (make before break. MBB.)
 Alternative. - Non-shorting. (break before make. BBM.)

Insulation.

Stator. - Moulded glass fibre loaded diallylphthalate (DAP)
 Rotor. - Polycarbonate.

Finish.

Index Springs, Stainless steel: other metal parts, passivated zinc plated. Finishes to order.

Mounting Details.

Imperial (standard). Metric (alternative)
 Bush 3/8" x 32TPI (Whit.) M10 x 0.75.
 Shaft 0.25" dia. 6mm, dia.
 Nut 0.525" A/F. 14mm A/F.
 The alternative is optional in each case.
 Unless otherwise specified, each switch is supplied with an internal tooth steel lock washer.

Construction.

The switch wafers are spaced by tubular metal spacers and held in place, with a positive relationship to the index mechanism, by side strut screws.

General Information The MSD is essentially a Heavy Duty rotary switch which is rated at 6amps. at 250Vac. Designed to handle higher currents than is possible with normal types of leaf clip wafer switches. It is eminently suitable for use in a wide variety of electronic and domestic equipment.
Developed by NSF technical service to incorporate modern materials and techniques which give the switch a greatly extended life at it's full current rating.

Electrical

Characteristics.

Maximum working voltage	250Vac.
Contact rating.	with resistive/non-inductive load
	6 amps at 250Vac. (rms)
	10 amps at 30 Vdc.
Proof Voltage	2000 Vdc for 1 minute.
Insulation resistance	greater than 10 ³ megohms.
	between adjacent contact or contact and frame)
Contact resistance (initial)	less than 5 milliohms at 2.5 Vdc 1 amp.
Contact life	a minimum of 5,000 cycles at rated current and voltage.

Maximum switching per wafer.

No. of Poles.	
1 Pole.	2 to 12 ways
2 Pole.	2 to 6 ways
3 Pole.	2 to 4 ways
4 Pole.	2 or 3 ways

Contacts. Contacts are copper, silver plated.

Rotor Contacts. Break-before-make only.

Index Mechanism. The 'U' type mechanism is used where one or two wafers are required, the type HD for switches with two or three. For more than three wafers please refer to our technical service.
The low friction moulded cam and followers in the 'U' type assembly ensure a smooth and positive indexing action. Balanced pressure springs provide consistent and readily reproducible torque values which can be approximated as...

- | | | |
|----------|---|--|
| - Light | - | Not greater than 0.18Nm. (25oz.Ins.) |
| - Medium | - | Greater than 0.14Nm. (20Oz.Ins) but less than 0.32Nm. (45Oz.Ins) |
| - Heavy | - | Greater than 0.28Nm. (40Oz.Ins.) |

Terminals. Solder Lug.

Insulation.

Stator	-	Glass fibre loaded diallylphthalate.
Rotor	-	Glass filled nylon.

Finish. Standard Ferrous parts zinc plated, non-ferrous parts clean.

Mounting Details.

Imperial (standard).	Metric (alternative)
Bush 3/8" x 32TPI (Whit.)	M10 x 0.75.
Shaft 0.25" dia.	6mm, dia.
Nut 0.525" A/F.	14mm A/F.

The alternative is optional in each case.
Unless otherwise specified, each switch is supplied with an internal tooth steel lock washer.
Panel and spindle seals can be fitted allowing sealing to 1cm³/hr.

Standard contacts. Each wafer comprises two stators interconnected by a rotor. One to six multiple position contacts are fitted to one stator whilst the other has up to 12 individual contacts. The rotor is fitted with up to 4 contacts to give the number of poles and ways required.

Variations.

1. Biased indexing is available giving momentary contact on positions 8 to 7, 5 to 4, 4 to 3, 3 to 2 and 2 to 1 as well as 3 position biased to centre.
2. Concentric shafts - dual concentric shafts and mechanisms for dual switching applications.
(Not available for 36° indexing).
3. Insulated shafts.
4. Electrostatic shields.
5. Printed circuit termination's - 2 types are available giving a variation in mounting height of the wafer above the P.C. board.
6. Adjustable stops - 2 types are available.
Front - can be set without dismantling the switch and are available on models MU-MA (a),(d) and A-MA with imperial bush.
Rear - for use with all other indexing variations both Imperial and Metric versions.
7. Panel and spindle seals can be fitted 1cm²/hr. The latter are not available on concentric shaft models.

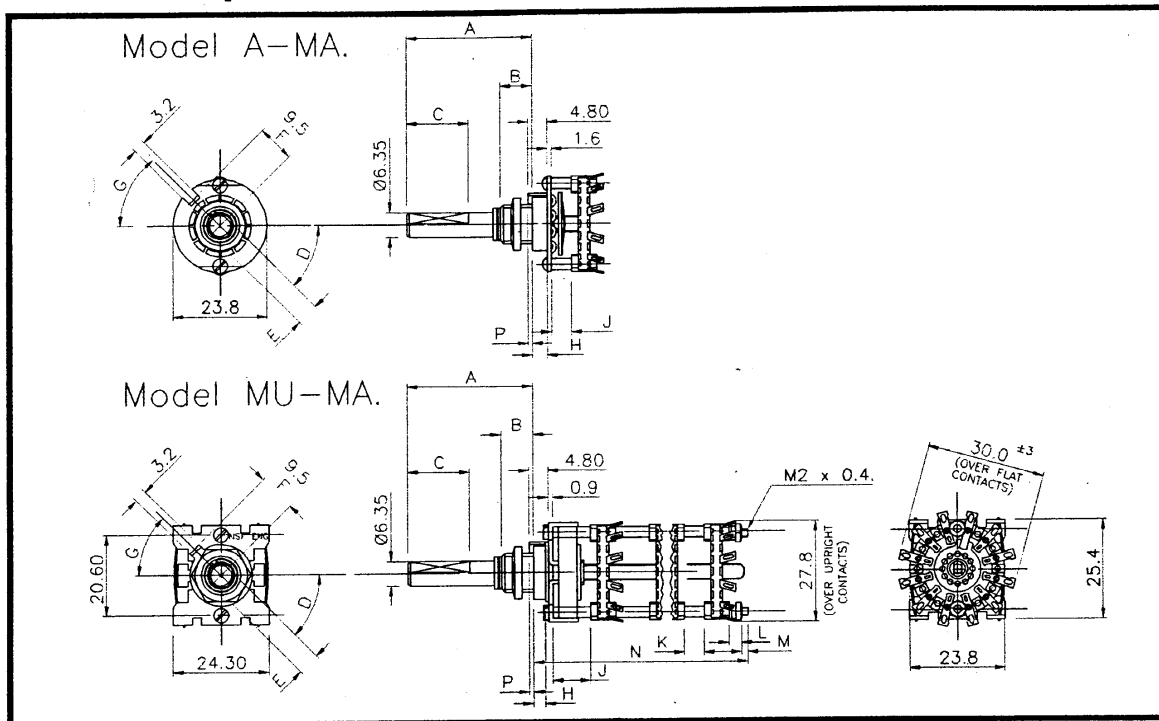

DIMENSIONS ARE IN MILLIMETRES.

Key to Details.

- | | |
|--|---|
| <p>A. Shaft length: optional ± 0.40 (0.016")</p> <p>B. Bushing thread length: preferred standard 9.5 (0.375"); 6.35 (0.250") available as an alternative. Special lengths if necessary</p> <p>C. Flat length: length to specification. Tolerance ± 0.40 (0.016"). Special shaft termination's may be provided to special requirements.</p> <p>D. Angle of flat: to specification $\pm 2^\circ$; specify position of flat, with switch shaft in fully anti-clockwise position when viewed from front or knob end.</p> <p>E. Flat thickness: standard 5.55 ± 0.15 (0.218" ± 0.005") for grub screws; 4.95 ± 0.05 (0.195" ± 0.002") for push-on knobs.</p> <p>F. Distance of locating lug from shaft, centre line to centre line.</p> <p>G. Angle of locating lug: type MU mechanism; $45^\circ, 135^\circ, 225^\circ$ and 315° from horizontal centre line; type A mechanism also includes 0° and 180° as viewed.</p> | <p>H. Bushing shoulder; standard 3.2 (0.125")</p> <p>J. Front spacer, minimum dimension: MU-MA 9.5 (0.375"), A-MA 4.8 (0.187").</p> <p>K. Other spacers: minimum dimensions.
Clips facing same direction NIL.
Clips facing away or flat clips NIL.
Clips facing each other 3.2 (0.125")</p> <p>L. If no spacer 2.4 (0.093"). Any length spacer desired may be inserted at this point.</p> <p>M. Thread extension: 1/8"(min) x M2 x 0.4 any length desired.</p> <p>P. Standard locating lug lengths:
MU-MA,
unsealed, projects 1.6 (0.062") beyond mounting face;
sealed, 0.05/0.15 (0.002"/0.006") below mounting face;
A-MA,
projects 4.8 (0.187") beyond mounting face.</p> |
|--|---|

Revised May 1999.

© NSF Controls Limited.

N.S.F. MODEL ~~101500~~ / JMK SWITCH

N.S.F. SPEC No. 4-59103 JMK1

SHEET 2

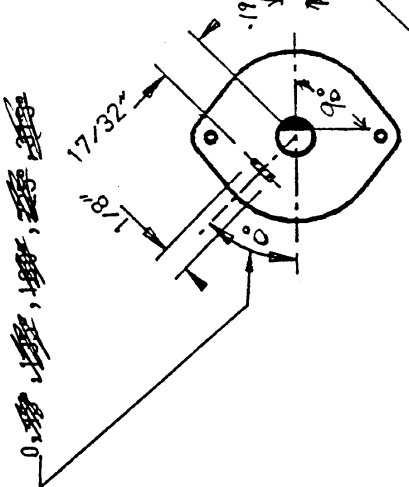
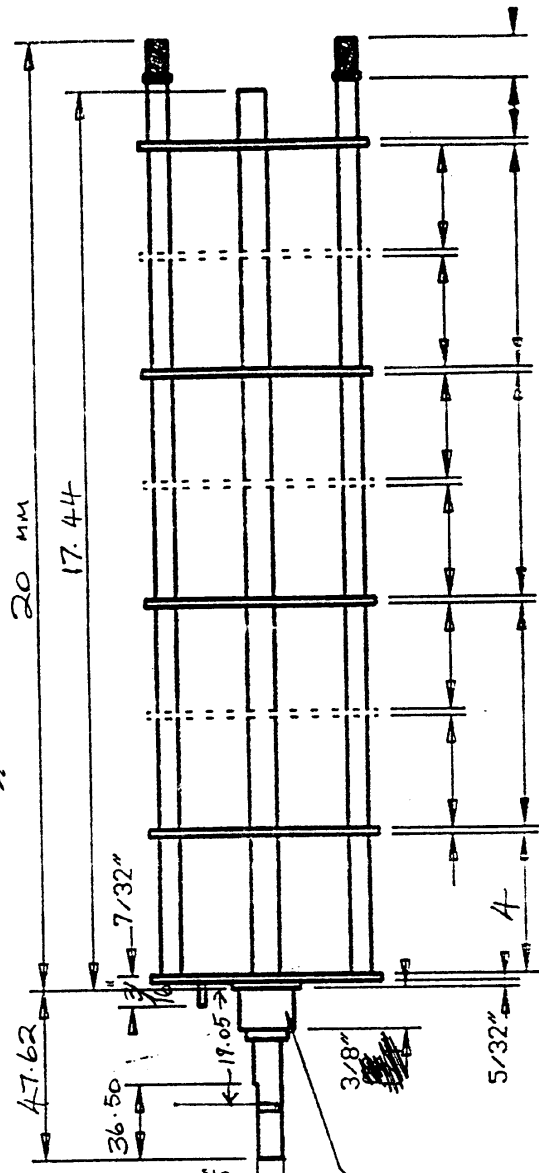

NOTES

- No OF SECTIONS 1
- No OF POSITIONS 2 TO 7 ADJ. STPS
- NON SHORTING
- TROPICAL 101500-COMMERCIAL
- STAMP PART No
- TORQUE
- SPRING

GROOVE IN SHAFT END TO BE 1/32 WIDE X 1/16 DEEP

FRONT

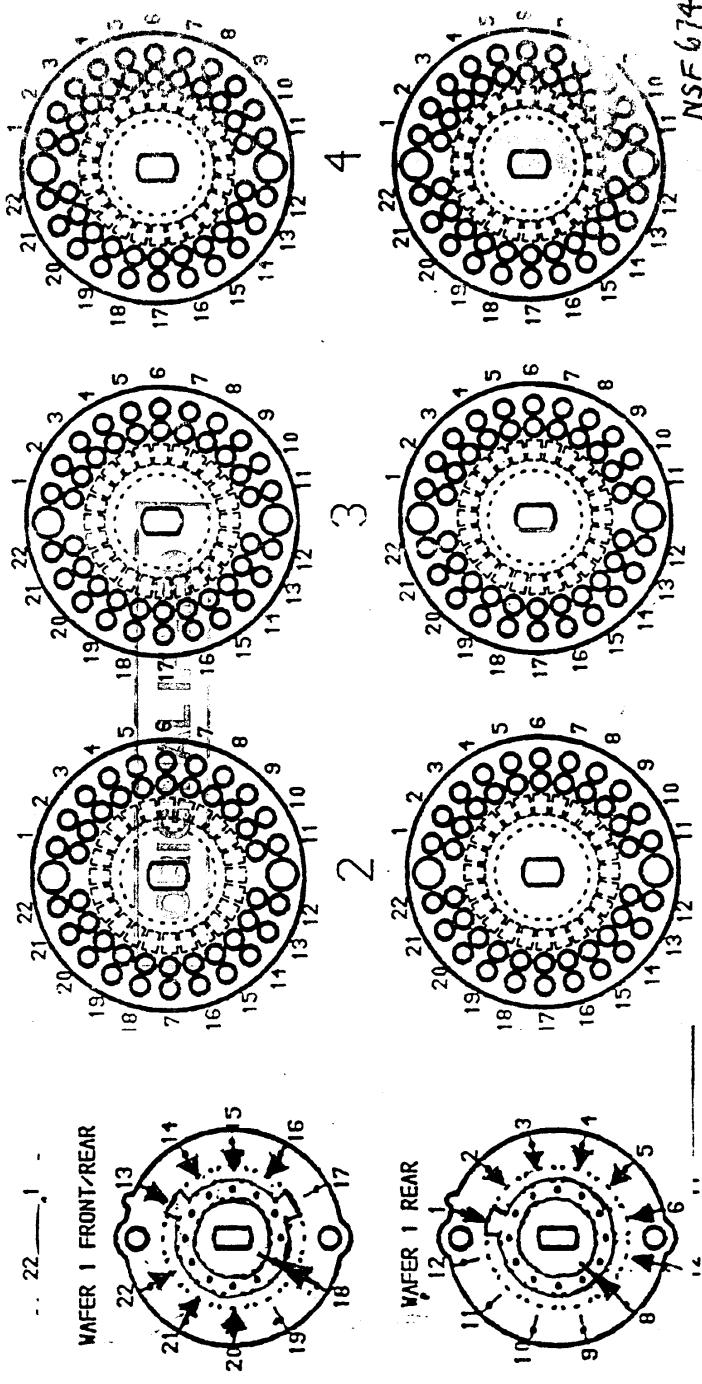

CHANGES

ISSUE	DATE	CHANGE

RAISED: 109 CHECKED: DATE: 7/54
 CUSTOMER WAS 4-0646 JMK1
 PART No.

N.S.F. SPEC No. 4-59103 JMK1

NSF 674

Construction.

The switch wafers are spaced by tubular metal spacers and held in place, with a positive relationship to the index mechanism assembly, by side strut screws.

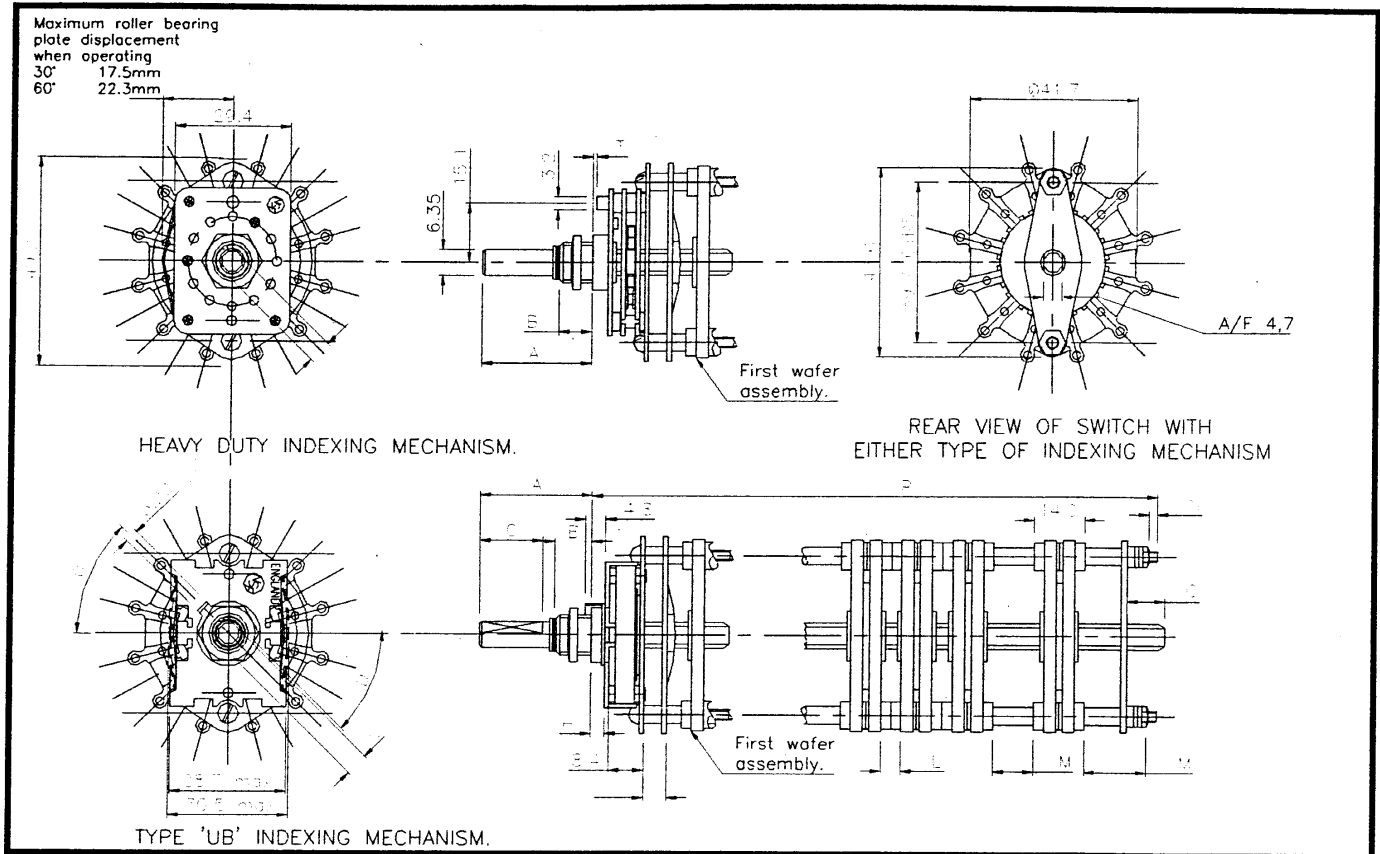

DIMENSIONS ARE IN MILLIMETRES.

Key to Details.

- | | |
|--|--|
| <p>A. Shaft length: optional ± 0.40 (0.016")</p> <p>B. Bushing thread length: preferred standard 9.5 (0.375"); 6.35 (0.250") available as an alternative. Special lengths if necessary</p> <p>C. Flat length: length to specification. Tolerance ± 0.40 (0.016"). Special shaft terminations may be provided to special requirements.</p> <p>D. Angle of flat: to specification $\pm 2^\circ$; specify position of flat, with switch shaft in fully anti-clockwise position when viewed from front or knob end.</p> <p>E. Flat thickness: standard 5.55 ± 0.15 (0.218" ± 0.005") for grub screws; 4.95 ± 0.05 (0.195" ± 0.002") for push-on knobs.</p> <p>F. Distance of locating lug from shaft, centre line to centre line.
Type 'U' 9.5 (0.375")
Type 'HD' 15.1 (0.594")</p> <p>G. Angle of locating lug:
Type 'U' 45°, 135°, 225° or 315°.
Type 'HD' 90° or 270°.</p> | <p>H. Bushing shoulder, standard 3.2 (0.125")</p> <p>I. Combined bearing strap and spacer, minimum 5.55 (0.22")</p> <p>L. Spacing. 5.0 (0.2") minimum spacing between contacts.</p> <p>M. Any length spacer desired may be inserted at this point. Last spacer dimension will include 5.55 (0.22") for combined bearing strap and spacer.</p> <p>N. Thread extension: 3.2mm (1/8" min) x M2,5 any length desired.</p> <p>P. Specify maximum overall length if important.</p> <p>Q. Shaft extension at rear: nominal 1/8" to 1/4". any length as desired if specified.</p> <p>T. Length of locating pin 0.05 to 0.30 (0.002" to 0.012") below mounting face of bush (Sealed type). unsealed type 4.8 (0.187")</p> |
|--|--|

Revised June 1999.

© NSF Controls Limited.