

成型尺寸	公差
5mm 以下	±0.2
5~20mm	±0.3
20~40mm	±0.4
40~60mm	±0.5
60~100mm	±0.8
100mm 以上	±1.0

REVISIONS			
REV	DESCRIPTION	DATE	BY

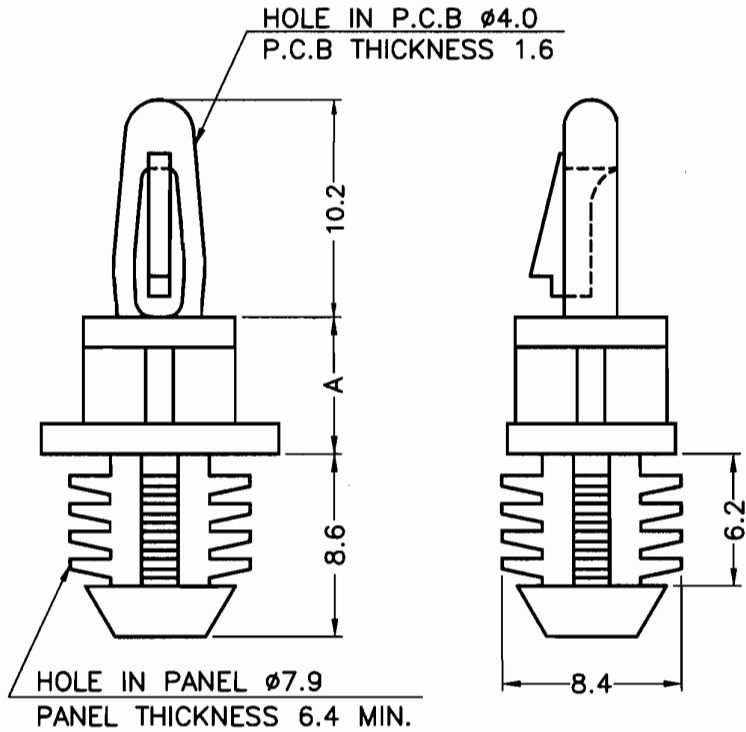

PART NO.	A
WBH-5	4.8
WBH-6	6.4
WBH-9	9.5
WBH-11	11.1
WBH-12	12.7
WBH-16	15.9
WBH-19	19.1
WBH-22	22.2
WBH-25	25.4

QMF22 Component - Plastics
 E I DUPONT DE NEMOURS & CO INC
 ENGINEERING POLYMERS CHESTNUT RUN PLAZA PO BOX 80713 WILMINGTON DE 19880

Wednesday, September 15, 2004 E41938

Material Designation: 101(+XFI), 101R(+XFI), 101L(+XFI), E101(+XFI), E101L(PI), 132P(+XFI), 135P(+XFI)
 Product Description: Polyamide 66 (PA66), designated "Zytel" furnished as pellets.

Color	Min. Thick. (mm)	Flame Class	HWI	HAI	RTI Elec	RTI Imp	RTI Str	IEC GWIT	IEC GWFI
ALL	0.71	V-2	4	0	130	75	85	725	960
	1.5	V-2	3	0	130	75	85	750	960
	3	V-2	2	0	130	75	85	800	960
	6	V-2	2	0	130	75	85	800	960

CTI: 0 HVTR: 0 D495: 6 IEC Ball Pressure (Cb) -
 Dielectric Strength @V/mm: 13 Volume Resistivity (10¹⁵ohm-cm): 14 Dimensional Stability(M) -
 ISO Tensile Strength (MPa): 180 Flexural Strength (MPa): 180 Heat Deflection (Cb) -
 ISO Tensile Impact (kJ/m²): 180 Izod Impact (kJ/m²): 180 Charpy Impact (kJ/m²): 180

(+) Virgin and regrind up to 50% by weight inclusive, have the same basic material characteristics.
 (PI) Suitable for outdoor use with respect to exposure to Ultraviolet Light, Water Exposure and Immersion in accordance with UL 746C.

NOTE (1) Material designations that are color pigmented may be followed by suffix letters and numbers. (2) Material designations may be prefixed by "ZYT" or "MIN" or "ZEN" or "DEL" or "CRA" or "RYN".

Report Date: 7/29/1996 Underwriters Laboratories Inc®

UL94 small-scale test data does not pertain to building materials, furnishings and related contents. UL 94 small-scale test data is intended solely for determining the flammability of plastic materials used in components and parts of end-product devices and appliances, where the acceptability of the combination is determined by UL.

康揚企業股份有限公司
 KANG YANG HARDWARE ENTERPRISE CO., LTD.
東莞康揚塑膠五金電子廠
 DONG GUAN KANG YANG PLASTIC HARDWARE COMPANY
康哲電腦配件(吳江)有限公司
 KANG CHEE COMPUTER COMPONENTS(WUJIANG) CO.,LTD.

TITLE	PC板間隔柱	產品規格圖面	
MATERIAL	NYLON 66 UL94V-2	DATE	1999.11.05
FINISH		DRAWN	Linda
COLOR	NATURAL	CHECK	高建和
UNLESS OTHERWISE SPECIFIED TOLERANCE	SEE ABOVE	APPROVED	Kang

PART NUMBER	SEE ABOVE	DRAWING NUMBER	WBH-
SIZE	A4	SCALE	NONE
UNIT	mm	REV	A