

CIRCUIT BOARD HARDWARE

A

Part No.	"A" mm	"B" mm
TCEHCBS-4-01	6.4	5.2
TCEHCBS-6-01	9.5	7.9
TCEHCBS-8-01	12.7	
TCEHCBS-10-01	15.9	
TCEHCBS-12-01	19.1	
TCEHCBS-14-01	22.2	

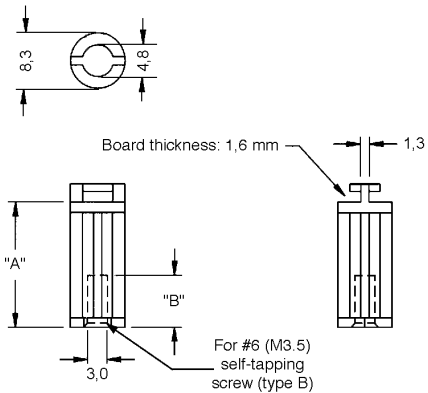
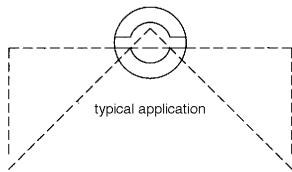

TCEHCBS

SCREW MOUNT CORNER / EDGE HOLDING
CIRCUIT BOARD SUPPORT

Material: Nylon 6/6 - natural; UL 94 V-2, RMS-01
or
Nylon 6/6 - natural; UL 94 V-0, RMS-19
Std. Pk.: 1.000 pcs.

Note:

TCEHCBS	6	01
Part	Length	Material Code

www.richco-int.com 
40