



ALL RIGHTS RESERVED. NO PORTION OF THIS PUBLICATION, WHETHER IN WHOLE OR IN PART, CAN BE REPRODUCED WITHOUT THE EXPRESS WRITTEN CONSENT OF SPC TECHNOLOGY.

SPC-F005.DWG

REVISIONS

DOC. NO. SPC-F005 * Effective: 7/8/02 * DCP No: 1398

DCP #	REV	DESCRIPTION	DRAWN	DATE	CHECKD	DATE	APPRVD	DATE
811	C	Renamed - was SPCS-*	JWM	8/24/01	JC	9/14/01	JC	9/14/01
1865	D	RoHS ADDED	DCM	10/17/05	JWM	10/18/05	JWM	10/18/05

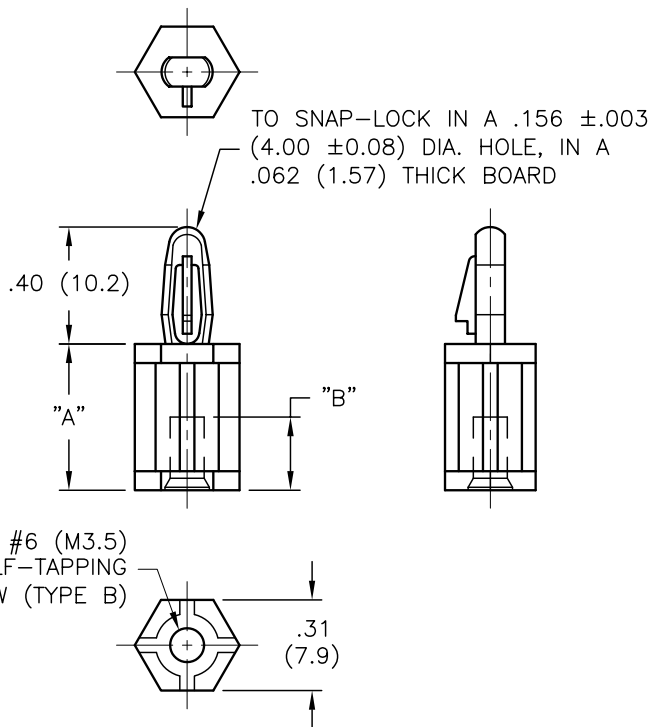

PART NO.	DIM "A"	DIM "B"
SPCS-4	1/4 (6.4)	13/64 (5.2)
SPCS-6	3/8 (9.5)	5/16 (7.9)
SPCS-8	1/2 (12.7)	
SPCS-12	3/4 (19.1)	
SPCS-14	7/8 (22.2)	

NOTES:

1. MATERIAL: NYLON 6/6
2. COLOR: NATURAL
3. FLAMMABILITY RATING: UL94V-2

DISCLAIMER:
ALL STATEMENTS AND TECHNICAL INFORMATION CONTAINED HEREIN ARE BASED UPON INFORMATION AND/OR TESTS WE BELIEVE TO BE ACCURATE AND RELIABLE. SINCE THE CONDITIONS OF USE ARE BEYOND OUR CONTROL, THE USER SHALL DETERMINE THE SUITABILITY OF THE PRODUCT FOR THE INTENDED USE AND ASSUME ALL RISK AND LIABILITY WHATSOEVER IN CONNECTION THEREWITH.

TOLERANCES:

Unless Otherwise Specified
Fractional Tolerance = $\pm 1/64$

DRAWN BY:	DATE:
JC	9/23/91
CHECKED BY:	DATE:
JC	9/23/01
APPROVED BY:	DATE:
JC	9/23/01

DRAWING TITLE:

Screw-Mount Circuit Board Support

SIZE	DWG. NO.	ELECTRONIC FILE	REV
A	TA-393	TA-393.dwg	D
SCALE: NTS	U.O.M.: INCHES [mm]	SHEET: 1 OF 1	