

REVISIONS		REVISED DATE	APPR
SYM	DESCRIPTION		

FULL SECTION

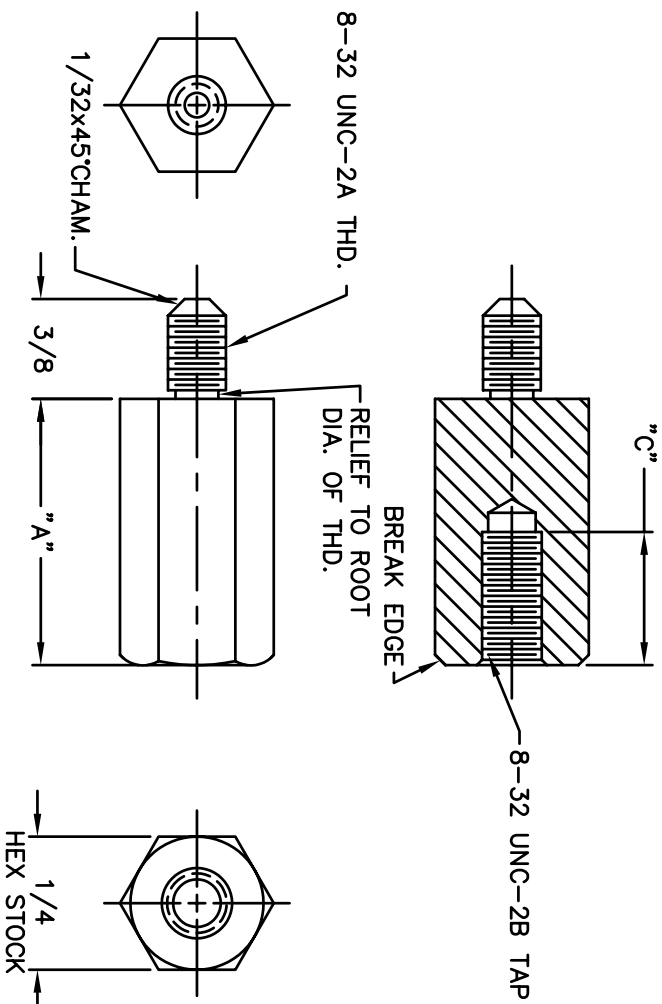

STANDOFF		
PART NO.	LENGTH	"C" NO. THDS
8280	.250	3-4
8281	.375	6-7
8282	.500	10-11
8283	.625	12-13
8284	.750	12-13
8285	.875	12-13
8286	1.000	12-13
8287	1.125	12-13
8288	1.250	12-13
8289	1.375	12-13
8290	1.500	12-13
8291	1.625	12-13
8292	1.750	12-13
8293	2.000	12-13
8294	2.500	12-13
8295	3.000	12-13

MATERIAL: BRASS-ALLOY 360-1/2 HARD		FINISH: NICKEL	
DIMENSIONAL TOLERANCES UNLESS OTHERWISE SPECIFIED		TITLE: 8280-8295	
XX	XXX	XXXX	BRASS HEX
---	---	---	MALE/FEMALE STANDOFF
FRACTIONS	ANGLES	SCALE	
---	---	4X	
HEAT TREAT:	---	DRAWN: T. LORD	DATE: 01/7/03
PLT SCALE: 1=1	---	CHECKED: T. LORD	DATE: 01/7/03
		APPROVED: T.LORD	DATE: 01/7/03
ABBATRON Electronic Connectors and Hardware 13680 S. MOSERTOWN RD MEADVILLE, PA 16335		SIZE: B	DRAWING NUMBER: SD: 8280-8295
			ISSUED: F