

REVISIONS			DOC. NO. SPC-F004 * Effective: 7/8/02 * DCP No: 1398						
DCP #	REV	DESCRIPTION	DRAWN	DATE	CHECKD	DATE	APPRVD	DATE	
564	C	REVISED & ADDED MORE PARTS	HYO	4/3/00	JC	6/5/00	JC	6/5/00	
1892	D	Update To RoHS Compliant	EO	3/14/06	HO	3/15/06	HO	3/15/06	

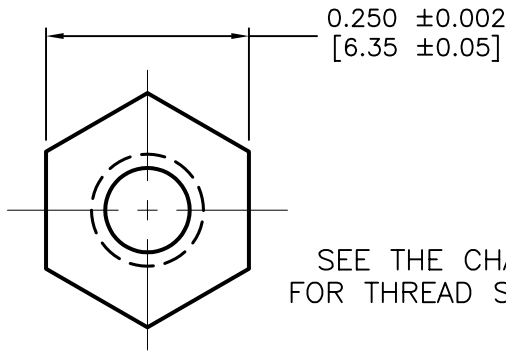

SEE THE CHART FOR THREAD SIZE

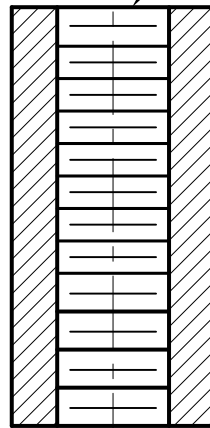
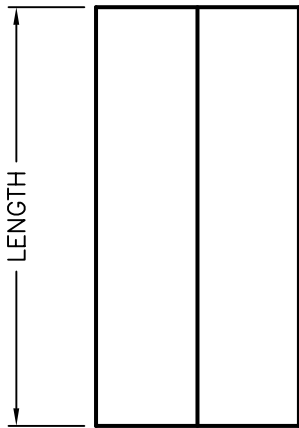

SPC Type No.	THREAD SIZE	LENGTH (INCHES)
HTB-4-250-A	4-40	0.250
HTB-4-375-A		0.375
HTB-4-500-A		0.500
2747		0.625
HTB-4-750-A		0.750
2748		0.875
HTB-4-1000-A		1.000
2749		1.500
2750		2.000
HTB-6-250-A		6-32
HTB-6-375-A	0.375	
HTB-6-500-A	0.500	
2744	0.625	
HTB-6-750-A	0.750	
2751	0.875	
HTB-6-1000-A	1.000	
2745	1.500	
2746	2.000	
HTB-8-250-A	8-32	0.250
HTB-8-375-A		0.375
HTB-8-500-A		0.500
2752		0.625
HTB-8-750-A		0.750
2753		0.875
HTB-8-1000-A		1.000
2754	1.500	
2755	2.000	

NOTES:

1. MATERIAL: BRASS, ASTM-B16
2. FINISH: ZINC, PLATED PER QQ-Z-325B
3. SPACERS OVER 1.00 LONG ARE TAPPED 0.375 DEEP EACH END

TOLERANCES: UNLESS OTHERWISE SPECIFIED DECIMALS .XXX ± 0.005 [0.15]	DRAWN BY:	DATE:	DRAWING TITLE:			
	J.P.	4/12/93	HEX STANDOFF, THREADED, BRASS			
	CHECKED BY:	DATE:	SIZE	DWG. NO.	ELECTRONIC FILE	REV
	J.C.	4/13/93	A	TA-246	TA-246.DWG	D
APPROVED BY:	DATE:	SCALE: NTS		U.O.M.: INCHES [mm]	SHEET: 1 OF 1	
K.D.	4/13/93					

ALL RIGHTS RESERVED. NO PORTION OF THIS PUBLICATION, WHETHER IN WHOLE OR IN PART CAN BE REPRODUCED WITHOUT THE EXPRESS WRITTEN CONSENT OF SPC TECHNOLOGY. DISCLAIMER: ALL STATEMENTS AND TECHNICAL INFORMATION CONTAINED HEREIN ARE BASED UPON INFORMATION AND/OR TESTS WE BELIEVE TO BE ACCURATE AND RELIABLE. SINCE CONDITIONS OF USE ARE BEYOND OUR CONTROL, THE USER SHALL DETERMINE THE SUITABILITY OF THE PRODUCT FOR THE INTENDED USE AND ASSUME ALL RISK AND LIABILITY WHATSOEVER IN CONNECTION THEREWITH.