

A	B	C	D	E	F	
PART NUMBER	'T' DIM	MOUNTING HOLE DIA.	'C' DIM	'D' DIM	'E' DIM	FIG No.
MMB-125-XX	2.0-2.5 (0.080-0.100)	3.10-3.22 (0.123-0.127)	1.0 (0.040)	6.9 (0.270)	8.4 (0.330)	1
MMB-136-XX	2.9-4.0 (0.120-0.160)	3.32-3.58 (0.131-0.141)	1.7 (0.070)	10.3 (0.410)	11.1 (0.440)	
MMB-187-XX	2.5-4.0 (0.100-0.160)	4.61-4.88 (0.182-0.192)	2.2 (0.090)	12.7 (0.500)	10.9 (0.430)	
MMB-210-XX	2.5-4.0 (0.100-0.160)	5.0-5.4 (0.197-0.213)	3.0 (0.118)	14 (0.551)	14 (0.551)	2
MMB-250-XX	2.5-5.6 (0.100-0.220)	6.27-6.42 (0.247-0.253)	2.2 (0.090)	12.7 (0.500)	16.3 (0.640)	1

REV.	MODIFICATION.	DATE	DRN
01	NEW DWG, ECN 05-049	13/04/05	NJB
02	ECN05-038	21/07/05	OW
03	ECR05-095	31/08/05	OW

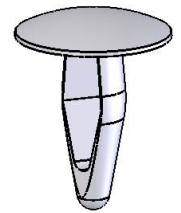
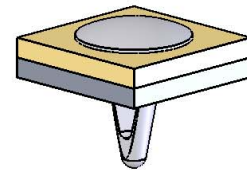

ISOMETRIC VIEWS

NOTES

- 1a) METRIC PRIMARY UNITS:mm
- 1b) IMPERIAL SECONDARY UNITS: [inches]
- 2) FLAME RETARDANT NYLON (RMS-19), & ACETAL (RMS-14) AVAILABLE BY SPECIAL ORDER.

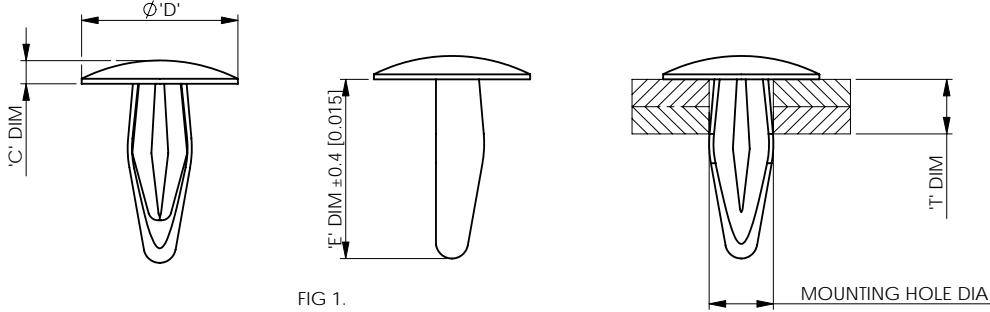

FIG 1.

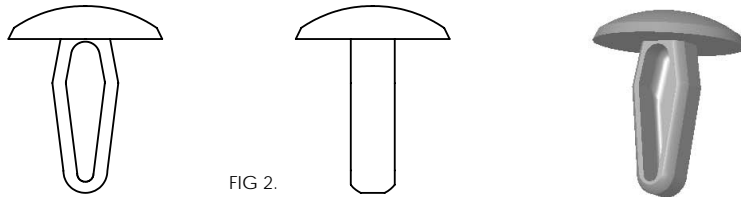

FIG 2.

INFORMATION CONTAINED IN THIS DOCUMENT IS CONFIDENTIAL TO RICHCO INTERNATIONAL Co. Ltd. AND MAY NOT BE DISCLOSED OR REPRODUCED IN WHOLE OR PART WITHOUT THEIR WRITTEN CONSENT.



GENERAL TOLERANCES ±0.25 (0.010) UNLESS OTHERWISE STATED
 1 DECIMAL PLACE ±
 2 DECIMAL PLACES ±
 ANGULAR ±1°



MMB-XXX-14	ACETAL (RMS-14)	NATURAL
MMB-XXX-19	NYLON 6/6 FR (RMS-19)	NATURAL OR BLACK
MMB-XXX-01	NYLON 6/6 (RMS-01)	NATURAL OR BLACK
PART NUMBER	MATERIAL	COLOUR

MATERIAL: SEE TABLE		COLOUR: SEE TABLE	
DESCRIPTION: MINI MOUNTING BUTTON		PART No: MMB-XXX-YY	
DRG No: 05-043	NPR No: 2003-321	SHEET SIZE A4	
DRN NJB	DATE 13/04/05	CHKD OW	DATE 13/04/05
SCALE NTS		SHEET No. 1 OF 1	

FORM No. 0145/03