

| PART # | ASSEMBLED THICKNESS "T" | "A" REF. | "B" ±.010 (±0.25) | "C" ±.010 (±0.25) |
|------------|-------------------------|------------|-------------------|-------------------|
| BR1-226-01 | .235-.297(6.0-7.5) | .226(5.7) | .750(19.1) | .093(2.4) |
| BR1-344-01 | .346-.502(8.8-12.8) | .344(8.7) | | |
| BR1-488-01 | .500-.812(12.7-20.6) | .488(12.4) | | |
| BR1-768-01 | .781-1.375(19.8-34.9) | .768(19.5) | | |
| BR2-226-01 | .235-.297(6.0-7.5) | .226(5.7) | .406(10.3) | .062(1.6) |
| BR2-344-01 | .346-.502(8.8-12.8) | .344(8.7) | | |
| BR2-488-01 | .500-.812(12.7-20.6) | .488(12.4) | | |
| BR2-768-01 | .781-1.375(19.8-34.9) | .768(19.5) | | |

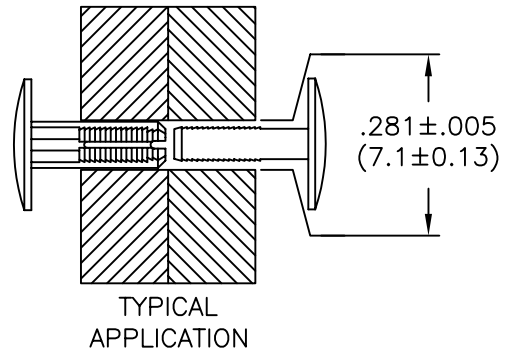
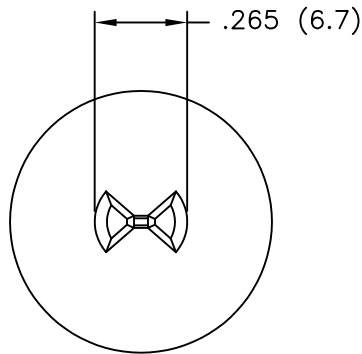
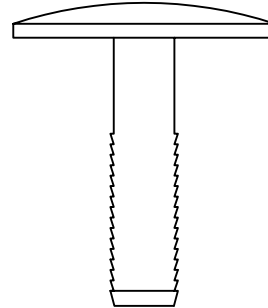
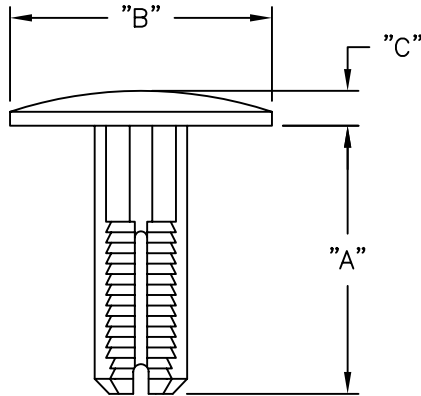

NOTES:

1. MOUNTING HOLE DIA. $.281 \pm .005$ (7.1 ± 0.13).
2. MATERIAL: NYLON 6/6 UL 94 V-2 (RMS-01).
COLOR: NATURAL.
NYLON 6/6 UL 94 V-0 (RMS-19)
AVAILABLE BY SPECIAL ORDER ONLY.
3. AVAILABLE IN CLEAR PROPIONATE (RMS-12) UPON REQUEST.

| | | |
|-----|---------------------------|----------------|
| D | SEE ECN #1265 FOR CHANGES | SK 12.12.06 |
| C | SEE ECN #715 FOR CHANGES | SM 10.09.03 |
| B | CHANGED FILE NUMBER | SM 05.24.01 |
| A | CHANGED DIMENSIONS | MH 09.04.97 |
| REV | DESCRIPTION | ENGR DATE |

TITLE:

BARBED RIVET

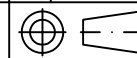

DWG IN
IN(MM)



FINAL

| | | | | | |
|---|---|--|-------------|---------------------|------------------|
| TOLERANCES UNLESS NOTED .XX=±.020 .XXX=±.015 FRAC=±1/64 ANG=±1° | FILE # BR MAT'L: SEE NOTES RE: RICHCO, INC. | DWN: M.H. DT: 09-04-97 | APP: DT: | PART # SEE TABLE | PRINT TYPE CA |
| | | RICHCO INC. PO BOX 804238, CHICAGO, 60680 (773) 539-4060 | | | |