

DCP #	REV	DESCRIPTION	DRAWN	DATE	CHECKD	DATE	APPRVD	DATE
1864		Released	JN	03/27/08	JN	03/27/08	JN	03/27/08

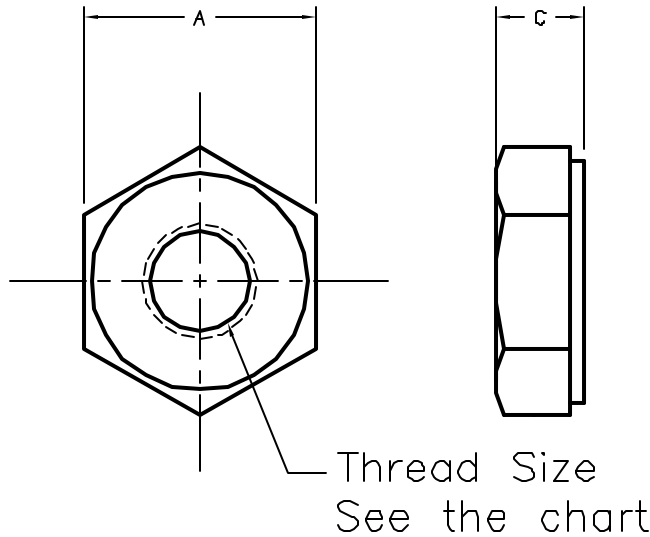

RoHS  
Compliant



SPC Type No.	Nut Type	Thread	A	B
SPC13378	Hex Nuts	2-56	.180±.01	.07±.01
SPC13379		4-40	.250±.01	.100±.01
SPC13380		10-32	.365±.01	.135±.01
SPC13410	Lock Nuts	2-56	.180±.01	.140±.01
SPC13411		4-40	.250±.01	.180±.01
SPC13412		6-32	.305±.01	.200±.01
SPC13413		8-32	.335±.01	.230±.01
SPC13414		10-32	.365±.01	.250±.01

SPC-F004.DWG

<p>TOLERANCES: UNLESS OTHERWISE SPECIFIED, DIMENSIONS ARE FOR REFERENCE PURPOSES ONLY.</p>	DRAWN BY:	DATE:	DRAWING TITLE:			
	Jason Nash	03/27/08	Hex Nuts and Lock Nuts			
	CHECKED BY:	DATE:	SIZE	DWG. NO.	ELECTRONIC FILE	REV
	Jason Nash	03/27/08	A	TA-855	TA-855.dwg	A
	APPROVED BY:	DATE:	SCALE:	U.O.M.:	SHEET:	
Jason Nash	03/27/08	NTS	INCHES [mm]	1 OF 1		

ALL RIGHTS RESERVED. NO PORTION OF THIS PUBLICATION, WHETHER IN WHOLE OR IN PART CAN BE REPRODUCED WITHOUT THE EXPRESS WRITTEN CONSENT OF SPC TECHNOLOGY. DISCLAIMER: ALL STATEMENTS AND TECHNICAL INFORMATION CONTAINED HEREIN ARE BASED UPON INFORMATION AND/OR TESTS WE BELIEVE TO BE ACCURATE AND RELIABLE. SINCE CONDITIONS OF USE ARE BEYOND OUR CONTROL, THE USER SHALL DETERMINE THE SUITABILITY OF THE PRODUCT FOR THE INTENDED USE AND ASSUME ALL RISK AND LIABILITY WHATSOEVER IN CONNECTION THEREWITH.