

# DATA SHEET

## **RM14/I**

## **RM cores and accessories**

Product specification  
Supersedes data of January 1999  
File under Ferrite Ceramics, MA01

1999 Dec 23

RM cores and accessories

RM14/I

CORE SETS

Effective core parameters

SYMBOL	PARAMETER	VALUE	UNIT
$\Sigma(l/A)$	core factor (C1)	0.353	mm <sup>-1</sup>
$V_e$	effective volume	13900	mm <sup>3</sup>
$l_e$	effective length	70.0	mm
$A_e$	effective area	198	mm <sup>2</sup>
$A_{min}$	minimum area	168	mm <sup>2</sup>
$m$	mass of set	≈74	g

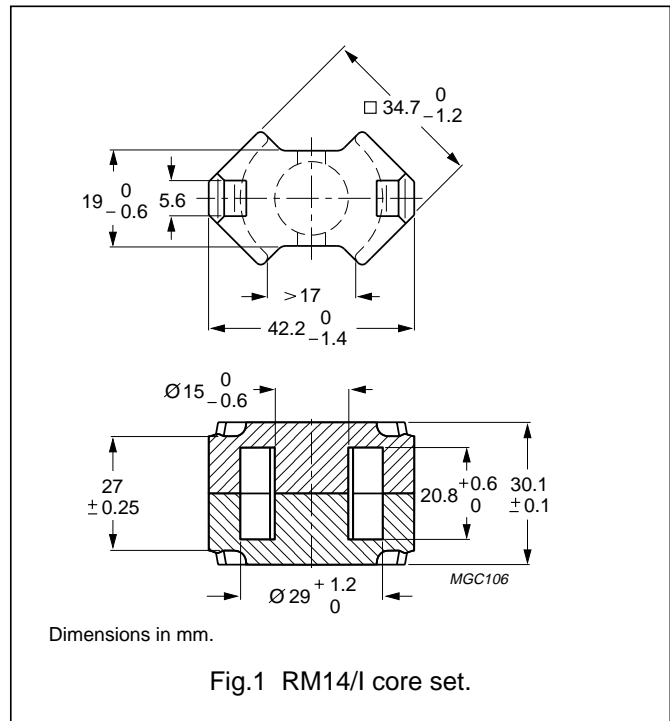

Core sets for general purpose transformers and power applications

Clamping force for  $A_L$  measurements, 80 ±20 N.

GRADE	$A_L$ (nH)	$\mu_e$	AIR GAP (μm)	TYPE NUMBER
3C90	250 ±3%	≈70	≈950	RM14/I-3C90-A250
	315 ±3%	≈88	≈700	RM14/I-3C90-A315
	400 ±3%	112	≈550	RM14/I-3C90-A400
	630 ±5%	≈177	≈250	RM14/I-3C90-A630
	1000 ±5%	≈281	≈150	RM14/I-3C90-A1000
	7100 ±25%	≈1990	≈0	RM14/I-3C90
3C94 <small>des</small>	250 ±3%	≈70	≈950	RM14/I-3C94-A250
	315 ±3%	≈88	≈700	RM14/I-3C94-A315
	400 ±3%	112	≈550	RM14/I-3C94-A400
	630 ±5%	≈177	≈250	RM14/I-3C94-A630
	1000 ±5%	≈281	≈150	RM14/I-3C94-A1000
	7100 ±25%	≈1990	≈0	RM14/I-3C94
3C96 <small>prot</small>	6200 ±25%	≈1740	≈0	RM14/I-3C96
3F3	250 ±3%	≈70	≈950	RM14/I-3F3-A250
	315 ±3%	≈88	≈700	RM14/I-3F3-A315
	400 ±3%	112	≈550	RM14/I-3F3-A400
	630 ±5%	≈177	≈250	RM14/I-3F3-A630
	1000 ±5%	≈281	≈150	RM14/I-3F3-A1000
	5700 ±25%	≈1600	≈0	RM14/I-3F3

## RM cores and accessories

RM14/I

## Properties of core sets under power conditions

GRADE	B (mT) at	CORE LOSS (W) at			
	H = 250 A/m; f = 25 kHz; T = 100 °C	f = 25 kHz; B̂ = 200 mT; T = 100 °C	f = 100 kHz; B̂ = 100 mT; T = 100 °C	f = 100 kHz; B̂ = 200 mT; T = 100 °C	f = 400 kHz; B̂ = 50 mT; T = 100 °C
3C90	≥315	≤1.67	≤1.76	–	–
3C94	≥315	–	≤1.55	≈6.0	≈3.5
3C96	≥315	–	≈1.2	≈4.5	≈2.5
3F3	≥315	–	≤1.55	–	≤2.65

RM cores and accessories

RM14/I

COIL FORMERS

General data

PARAMETER	SPECIFICATION
Coil former material	phenolformaldehyde (PF), glass reinforced, flame retardant in accordance with "UL 94V-0", UL file number E167521(M)
Pin material	copper-tin alloy (CuSn), tin-lead alloy (SnPb) plated
Maximum operating temperature	180 °C, "IEC 60085" class H
Resistance to soldering heat	"IEC 60068-2-20", Part 2, Test Tb, method 1B, 350 °C, 3.5 s
Solderability	"IEC 60068-2-20", Part 2, Test Ta, method 1

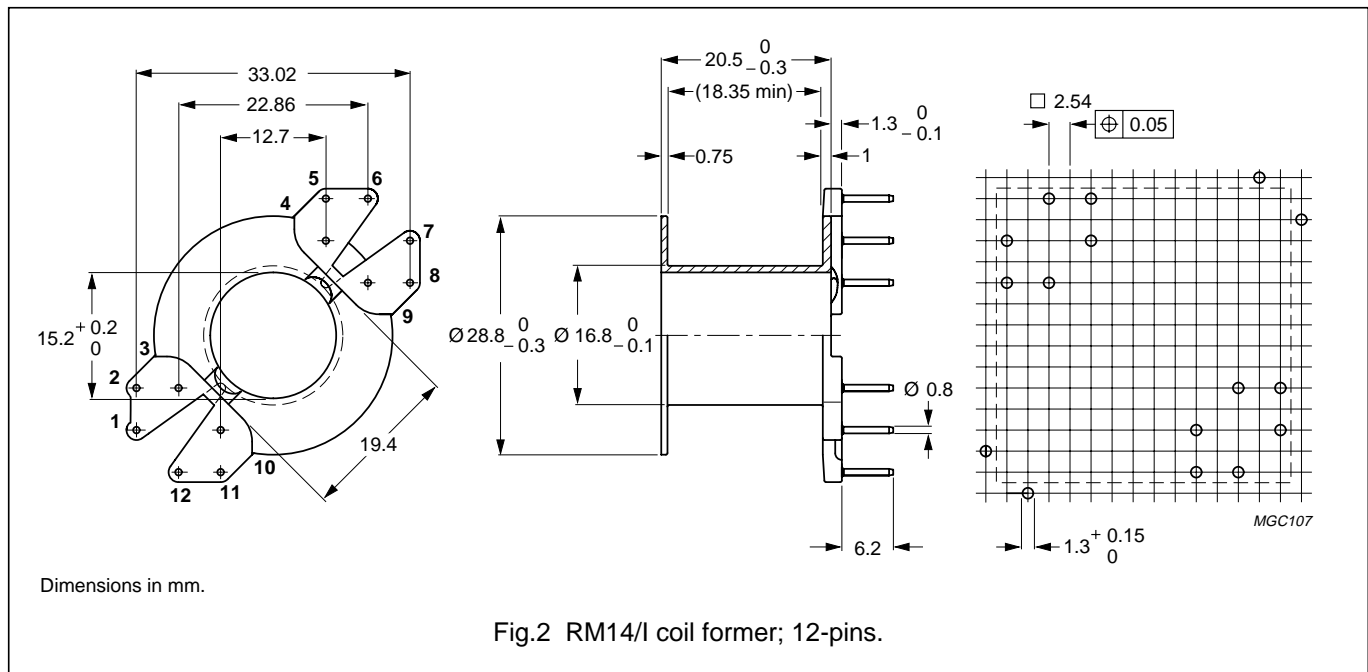

Winding data for 12-pins RM14/I coil former

NUMBER OF SECTIONS	NUMBER OF PINS	PIN POSITIONS USED	AVERAGE LENGTH OF TURN (mm)	WINDING AREA (mm <sup>2</sup> )	WINDING WIDTH (mm)	TYPE NUMBER
1	10	1, 2, 3, 4, 6, 7, 9, 10, 11, 12	71	112	18.4	CSV-RM14-1S-10P
1	12	all	71	112	18.4	CSV-RM14-1S-12P

RM cores and accessories

RM14/I

General data

PARAMETER	SPECIFICATION
Coil former material	polybutyleneterephthalate (PBT), glass-reinforced, flame retardant in accordance with "UL 94V-0", UL file number E45329(R)
Pin material	copper-tin alloy (CuSn), tin-lead alloy (SnPb) plated
Maximum operating temperature	155 °C, "IEC 60085" class F
Resistance to soldering heat	"IEC 60068-2-20", Part 2, Test Tb, method 1B, 350 °C, 3.5 s
Solderability	"IEC 60068-2-20", Part 2, Test Ta, method 1

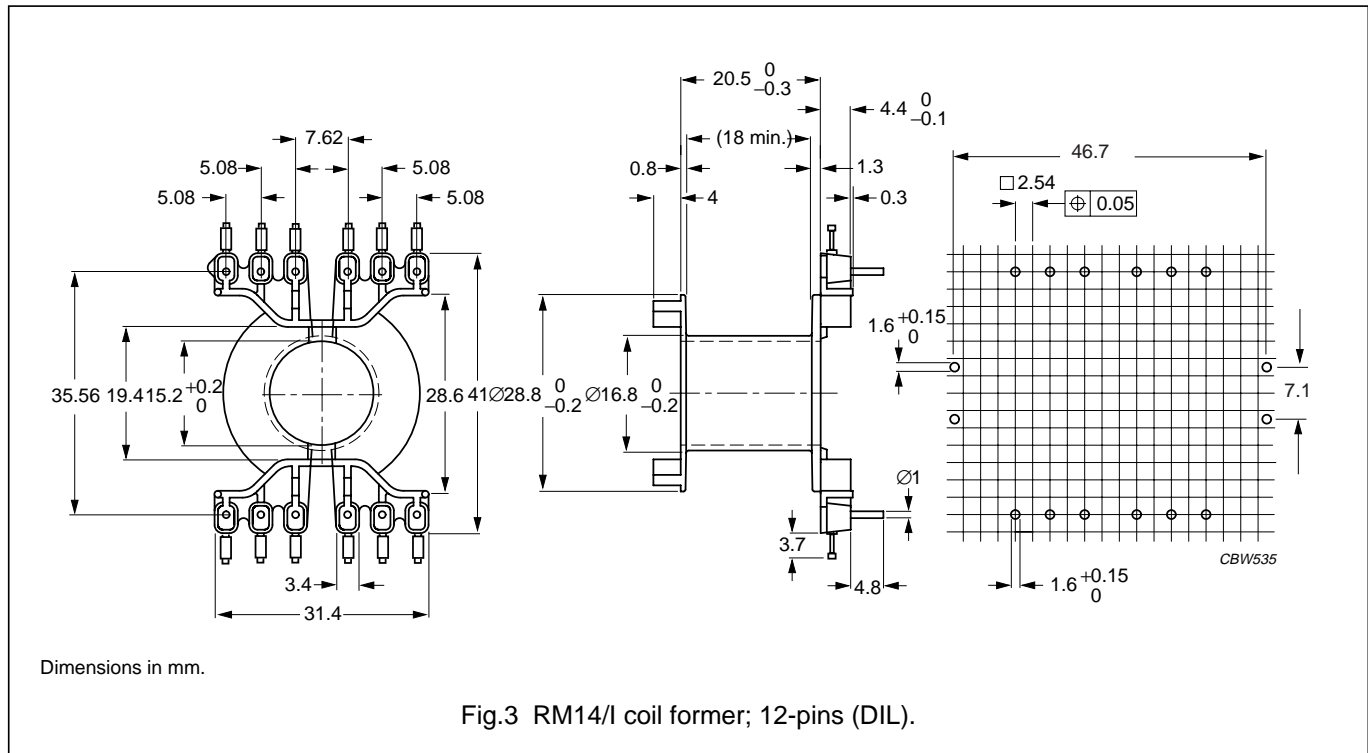

Winding data for 12-pins RM14/I coil former (DIL)

NUMBER OF SECTIONS	AVERAGE LENGTH OF TURN (mm)	WINDING AREA (mm <sup>2</sup> )	WINDING WIDTH (mm)	TYPE NUMBER
1	71	111	18.0	CPV-RM14/I-1S-12PD

RM cores and accessories

RM14/I

**MOUNTING PARTS**

**General data mounting clip with earth pin**

ITEM	SPECIFICATION
Clamping force	≈40 N
Clip material	stainless steel
Clip plating	tin-lead alloy (SnPb)
Solderability	"IEC 60068-2-20", Part 2, Test Ta, method 1
Type number	CLI/P-RM14/I

