

Wrenches

Klein's line of wrenches are forged from the finest steel and are designed to deliver great strength and long working life. Regardless of the job type, Klein has a wrench that will help the professional complete the task at hand.

For Professionals... Since 1857®

Wrenches



Adjustable Wrenches

Features:

Precision-machined jaws are individually chosen and assembled by hand for smooth operation.

Available in high-capacity.

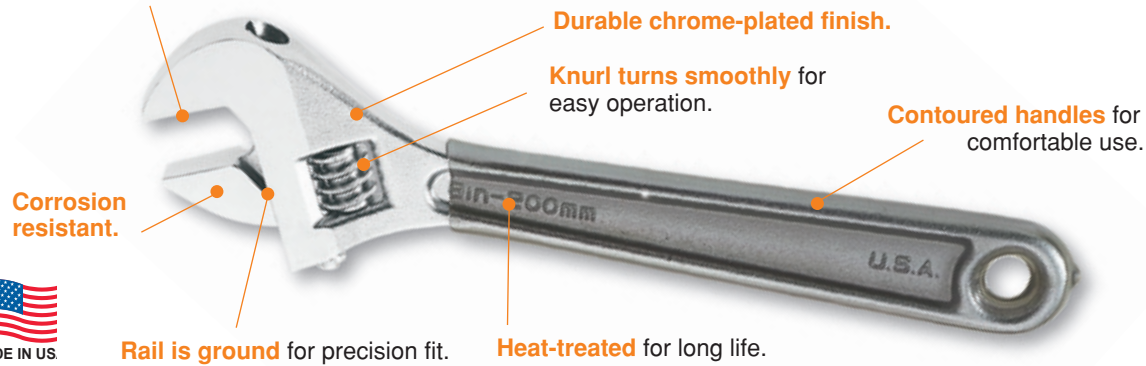

Adjustable Wrenches – Standard Capacity

Additional Features:

- Forged heat-treated alloy steel for maximum strength and light weight.
- High polish chrome finish.



506-8

Cat. No.	Handle Type	Handle Finish	Length	Capacity	Weight (lbs.)
506-4	dovetail	plain	4-1/4" (108 mm)	1/2" (12 mm)	.11
506-6	dovetail	plain	6-1/4" (158 mm)	3/4" (19 mm)	.25
506-8	dovetail	plain	8-1/4" (209 mm)	15/16" (23 mm)	.51
506-10	dovetail	plain	10-1/4" (260 mm)	1-1/8" (28 mm)	.86
506-12	dovetail	plain	12-1/4" (311 mm)	1-5/16" (33 mm)	1.32
506-15	tapered	plain	15-7/8" (403 mm)	1-11/16" (42 mm)	2.92
500-18	tapered	plain	18-1/4" (463 mm)	2-1/16" (52 mm)	4.67
500-24	tapered	plain	24" (610 mm)	2-1/2" (63 mm)	7.76

Adjustable Wrenches – Standard Capacity, Plastic-Dipped Handles

Additional Features:

- Plastic-dipped handles for added comfort.
- Forged heat-treated alloy steel for maximum strength and light weight.
- High polish chrome finish.



D506-8

Cat. No.	Handle Type	Handle Finish	Length	Capacity	Weight (lbs.)
D506-4	dovetail	plastic-dipped	4-1/2" (114 mm)	1/2" (12 mm)	.13
D506-6	dovetail	plastic-dipped	6-3/8" (162 mm)	3/4" (19 mm)	.27
D506-8	dovetail	plastic-dipped	8-3/8" (213 mm)	15/16" (23 mm)	.62
D506-10	dovetail	plastic-dipped	10-3/8" (264 mm)	1-1/8" (28 mm)	1.00
D506-12	dovetail	plastic-dipped	12-3/8" (315 mm)	1-5/16" (33 mm)	1.44
D506-15	tapered	plastic-dipped	15-1/8" (384 mm)	1-11/16" (42 mm)	3.21
D500-18	tapered	plastic-dipped	18-3/8" (467 mm)	2-1/16" (52 mm)	5.02
D500-24	tapered	plastic-dipped	24-1/4" (616 mm)	2-1/2" (63 mm)	8.26
HD506-4	dovetail	heavy-duty, plastic-dipped	4-1/2" (114 mm)	1/2" (12 mm)	.13
HD506-10	dovetail	heavy-duty, plastic-dipped	10-3/8" (264 mm)	1-1/8" (28 mm)	1.00
HD506-12	dovetail	heavy-duty, plastic-dipped	12-3/8" (315 mm)	1-5/16" (33 mm)	1.54

All dimensions are in inches and (millimeters).

▲WARNING: Always wear approved eye protection.

▲WARNING: Do NOT push or hammer wrench.

▲WARNING: NOT insulated. Plastic-dipped or slip-on plastic handles are NOT intended for protection against electrical shock.

▲WARNING: Do NOT extend handle length.



Adjustable Wrenches – Extra Capacity

Additional Features:

- Extra capacity allows use of a smaller size wrench to handle bigger jobs, especially in confined spaces.
- Forged heat-treated alloy steel for maximum strength and light weight.
- High polish chrome finish.



D507-8

Cat. No.	Handle Finish	Length	Capacity	Weight (lbs.)
507-6	plain	6-1/4" (158 mm)	15/16" (23 mm)	.25
507-8	plain	8-1/4" (209 mm)	1-1/8" (28 mm)	.51
507-10	plain	10-1/4" (260 mm)	1-5/16" (33 mm)	.86
507-12	plain	12-1/4" (311 mm)	1-1/2" (38 mm)	1.32
D507-6	plastic-dipped	6-3/8" (162 mm)	15/16" (23 mm)	.27
D507-8	plastic-dipped	8-3/8" (213 mm)	1-1/8" (28 mm)	.62
D507-10	plastic-dipped	10-3/8" (264 mm)	1-5/16" (33 mm)	1.00
D507-12	plastic-dipped	12-3/8" (315 mm)	1-1/2" (38 mm)	1.54
HD507-6	heavy-duty, plastic-dipped	6-3/8" (162 mm)	15/16" (23 mm)	.27
HD507-8	heavy-duty, plastic-dipped	8-3/8" (213 mm)	1-1/8" (28 mm)	.54
HD507-10	heavy-duty, plastic-dipped	10-3/8" (264 mm)	1-5/16" (33 mm)	1.00
HD507-12	heavy-duty, plastic-dipped	12-3/8" (315 mm)	1-1/2" (38 mm)	1.54

Adjustable Wrenches – Standard Capacity, Black Finish

Additional Features:

- Forged and heat-treated alloy steel for maximum strength and light weight.
- Industrial black finish for corrosion resistance.



D508-8

Cat. No.	Handle Finish	Length	Capacity	Weight (lbs.)
508-4	plain	4-1/4" (108 mm)	1/2" (12 mm)	.11
508-6	plain	6-1/4" (158 mm)	3/4" (19 mm)	.25
508-8	plain	8-1/4" (209 mm)	15/16" (23 mm)	.51
508-10	plain	10-1/4" (260 mm)	1-1/8" (28 mm)	.86
508-12	plain	12-1/4" (311 mm)	1-5/16" (33 mm)	1.32
508-15	plain	14-7/8" (378 mm)	1-11/16" (42 mm)	2.92
D508-4	plastic-dipped	4-1/2" (114 mm)	1/2" (12 mm)	.13
D508-6	plastic-dipped	6-3/8" (162 mm)	3/4" (19 mm)	.27
D508-8	plastic-dipped	8-3/8" (213 mm)	15/16" (23 mm)	.62
D508-10	plastic-dipped	10-3/8" (264 mm)	1-1/8" (28 mm)	1.00
D508-12	plastic-dipped	12-3/8" (315 mm)	1-5/16" (33 mm)	1.54
D508-15	plastic-dipped	15-1/8" (384 mm)	1-11/16" (42 mm)	3.21

Adjustable-Head Construction Wrench

- Versatile wrench fits nuts and bolts to 1-1/2" (38 mm).
- Eliminates the need to carry several fixed-size wrenches.
- Forged from select alloy steel with continuous-taper handle.
- Industrial black finish for corrosion resistance.



3239

Cat. No.	Max. Size Capacity	Length	Weight (lbs.)
3239	1-1/2" (38 mm)	16" (406 mm)	2.36

All dimensions are in inches and (millimeters).

▲WARNING: Always wear approved eye protection.

▲WARNING: Do NOT push or hammer wrench.

▲WARNING: NOT insulated. Plastic-dipped or slip-on plastic handles are NOT intended for protection against electrical shock.

▲WARNING: Do NOT extend handle length.



Combination Wrenches

Features:

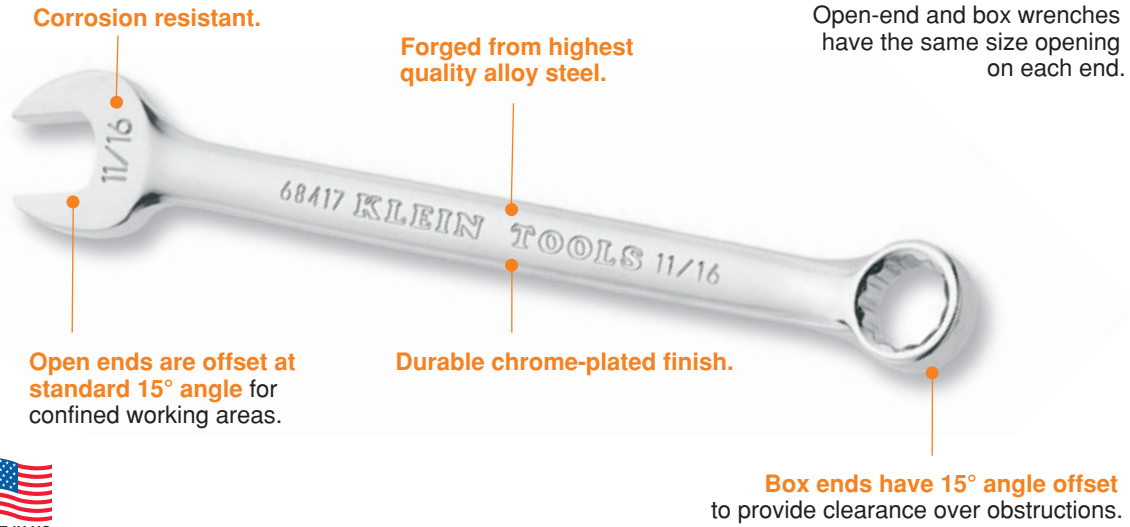

7-Piece Combination Wrench Set

Cat. No.	Set Contains	Weight (lbs.)
68400		1.23

Cat. No.	Size	Length	Box End Point
68410	1/4"	5-1/8"	12
68411	5/16"	4-3/8"	12
68412	3/8"	6-1/8"	12
68413	7/16"	6-3/8"	12
68414	1/2"	7-1/8"	12
68415	9/16"	7-1/2"	12
68416	5/8"	8-1/8"	12

Includes pouch with marked pockets for each wrench



68400

9-Piece Combination Wrench Set

Cat. No.	Set Contains	Weight (lbs.)
68402		2.07

Cat. No.	Size	Length	Box End Point
68410	1/4"	5-1/8"	12
68411	5/16"	4-3/8"	12
68412	3/8"	6-1/8"	12
68413	7/16"	6-3/8"	12
68414	1/2"	7-1/8"	12
68415	9/16"	7-1/2"	12
68416	5/8"	8-1/8"	12
68417	11/16"	9"	12
68418	3/4"	9-1/8"	12

Includes pouch with marked pockets for each wrench



68402

All dimensions are in inches.

▲WARNING: Always wear approved eye protection.

▲WARNING: Do NOT push or hammer wrench.

▲WARNING: Do NOT extend handle length.

12-Piece Combination Wrench Set

Cat. No.	Set Contains	Weight (lbs.)	
68404		4.13	
Cat. No.	Size	Length	Box End Point
68410	1/4"	5-1/8"	12
68411	5/16"	4-3/8"	12
68412	3/8"	6-1/8"	12
68413	7/16"	6-3/8"	12
68414	1/2"	7-1/8"	12
68415	9/16"	7-1/2"	12
68416	5/8"	8-1/8"	12
68417	11/16"	9"	12
68418	3/4"	9-1/8"	12
68419	13/16"	10-9/16"	12
68420	7/8"	11-1/2"	12
68421	15/16"	12-1/2"	12

Includes pouch with marked pockets for each wrench



68404

14-Piece Combination Wrench Set

Cat. No.	Set Contains	Weight (lbs.)	
68406		9.75	
Cat. No.	Size	Length	Box End Point
68412	3/8"	6-1/8"	12
68413	7/16"	6-3/8"	12
68414	1/2"	7-1/8"	12
68415	9/16"	7-1/2"	12
68416	5/8"	8-1/8"	12
68417	11/16"	9"	12
68418	3/4"	9-1/8"	12
68419	13/16"	10-9/16"	12
68420	7/8"	11-1/2"	12
68421	15/16"	12-1/2"	12
68422	1"	13-1/2"	12
68423	1-1/16"	14-5/8"	12
68424	1-1/8"	15-9/16"	12
68425	1-1/4"	16-7/8"	12

Includes pouch with marked pockets for each wrench



68406

Combination Wrenches

Cat. No.	Size	Length	Box End Point	Weight (lbs.)
68410	1/4"	5-1/8"	12	.05
68411	5/16"	4-3/8"	12	.05
68412	3/8"	6-1/8"	12	.10
68413	7/16"	6-5/8"	12	.14
68414	1/2"	7-1/8"	12	.18
68415	9/16"	7-1/2"	12	.23
68416	5/8"	8-1/2"	12	.28
68417	11/16"	9"	12	.37
68418	3/4"	9-7/8"	12	.46



68417

Cat. No.	Size	Length	Box End Point	Weight (lbs.)
68419	13/16"	10-5/8"	12	.53
68420	7/8"	11-1/2"	12	.67
68421	15/16"	12-1/2"	12	.79
68422	1"	13-1/4"	12	.93
68423	1-1/16"	14-1/4"	12	1.18
68424	1-1/8"	15-1/2"	12	1.52
68425	1-1/4"	16-3/4"	12	1.88

All dimensions are in inches.

▲WARNING: Always wear approved eye protection.

▲WARNING: Do NOT push or hammer wrench.

▲WARNING: Do NOT extend handle length.



Combination Wrenches – Metric

7-Piece Combination Wrench Set – Metric

Cat. No.	Set Contains	Weight (lbs.)
68500		1.21

Cat. No.	Size	Box End Point	Length
68507	7 mm	12	130 mm
68509	9 mm	12	155 mm
68510	10 mm	12	165 mm
68511	11 mm	12	165 mm
68513	13 mm	12	181 mm
68514	14 mm	12	191 mm
68515	15 mm	12	191 mm

Includes pouch with marked pockets for each wrench



68500

11-Piece Combination Wrench Set – Metric

Cat. No.	Set Contains	Weight (lbs.)
68502		2.35

Cat. No.	Size	Box End Point	Length
68507	7 mm	12	130 mm
68508	8 mm	12	137 mm
68509	9 mm	12	155 mm
68510	10 mm	12	165 mm
68511	11 mm	12	165 mm
68512	12 mm	12	181 mm
68513	13 mm	12	181 mm
68514	14 mm	12	191 mm
68515	15 mm	12	191 mm
68517	17 mm	12	229 mm
68519	19 mm	12	248 mm

Includes pouch with marked pockets for each wrench



68502

Combination Wrenches – Metric

Cat. No.	Size	Length	Box End Point	Weight (lbs.)
68507	7 mm	130 mm	12	.05
68508	8 mm	137 mm	12	.08
68509	9 mm	155 mm	12	.10
68510	10 mm	165 mm	12	.13
68511	11 mm	165 mm	12	.13
68512	12 mm	181 mm	12	.18



68512

Cat. No.	Size	Length	Box End Point	Weight (lbs.)
68513	13 mm	181 mm	12	.16
68514	14 mm	191 mm	12	.22
68515	15 mm	191 mm	12	.22
68517	17 mm	229 mm	12	.39
68519	19 mm	248 mm	12	.42



All dimensions are in inches or millimeters.

▲WARNING: Always wear approved eye protection.

▲WARNING: Do NOT push or hammer wrench.

▲WARNING: Do NOT extend handle length.

Open-End Wrenches

Features:

Corrosion resistant.

Forged from highest quality alloy-steel.

Different size opening on each end of wrench.

Ends are offset at 15° angle for clearance over obstructions.

Durable chrome-plated finish.



5-Piece Open-End Wrench Set

Cat. No.	Set Contains	Weight (lbs.)
68450		1.08

Cat. No.	Small Size	Large Size	Length
68460	1/4"	5/16"	4-3/4"
68461	3/8"	7/16"	6"
68462	1/2"	9/16"	7"
68463	9/16"	5/8"	7-1/2"
68464	11/16"	3/4"	9"

Includes pouch with marked pockets for each wrench



68450

7-Piece Open-End Wrench Set

Cat. No.	Set Contains	Weight (lbs.)
68452		2.46

Cat. No.	Small Size	Large Size	Length
68460	1/4"	5/16"	4-3/4"
68461	3/8"	7/16"	6"
68462	1/2"	9/16"	7"
68463	9/16"	5/8"	7-1/2"
68464	11/16"	3/4"	9"
68465	13/16"	7/8"	10"
68466	15/16"	1"	11"

Includes pouch with marked pockets for each wrench



68452

Open-End Wrenches

Cat. No.	Small Size	Large Size	Length	Weight (lbs.)
68460	1/4"	5/16"	4-3/4"	.04
68461	3/8"	7/16"	6"	.10
68462	1/2"	9/16"	7"	.17
68463	9/16"	5/8"	7-1/2"	.20
68464	11/16"	3/4"	9"	.36
68465	13/16"	7/8"	10"	.55
68466	15/16"	1"	11"	.80



68463

All dimensions are in inches or millimeters.

▲WARNING: Always wear approved eye protection.

▲WARNING: Do NOT push or hammer wrench.

▲WARNING: Do NOT extend handle length.

Wrenches



Socket Wrench Sets

8-Piece 1/2-Inch Drive Deep-Socket Set



65514

Set consists of the following pieces:

- Eight 12-point deep sockets: 1/2", 9/16", 5/8", 11/16", 3/4", 13/16", 7/8", and 15/16".
- Hinged metal box.

Cat. No.	Description	Weight (lbs.)
65514	complete 8-piece 1/2" drive, deep-socket set plus metal box	4.53

16-Piece 1/2-Inch Drive Socket Wrench Set



65512

Set consists of the following pieces:

- Thirteen 12-point sockets: 7/16", 1/2", 9/16", 5/8", 11/16", 3/4", 13/16", 7/8", 15/16", 1", 1-1/16", 1-1/8", and 1-1/4".
- One extension: 5" long.
- One flex handle: 17" long.
- One ratchet.
- Hinged metal box.

Cat. No.	Description	Weight (lbs.)
65512	complete 16-piece 1/2" drive set plus metal box	9.63

12-Piece 1/2-Inch Drive Socket Wrench Set



65510

Set consists of the following pieces:

- Nine 12-point sockets: 7/16", 1/2", 9/16", 5/8", 11/16", 3/4", 13/16", 7/8", and 15/16".
- One extension: 5" long.
- One spark plug socket: 5/8".
- One ratchet.
- Hinged metal box.

Cat. No.	Description	Weight (lbs.)
65510	complete 12-piece 1/2" drive set plus metal box	5.37

8-Piece 3/8-Inch Drive Deep-Socket Set



65502

Set consists of the following pieces:

- Eight 6-point deep sockets: 3/8", 7/16", 1/2", 9/16", 5/8", 11/16", 3/4" and 13/16".
- Hinged metal box.

Cat. No.	Description	Weight (lbs.)
65502	8-piece deep-socket 3/8" drive set plus metal box	2.66

All dimensions are in inches and (millimeters).

⚠WARNING: Always wear approved eye protection.



9-Piece 3/8-Inch Drive "D" Socket Wrench Set



Special tool selection for telephone work on cable enclosures and pole hardware.

Set consists of the following pieces:

- Four 6-point deep sockets: 3/8", 7/16", 1/2", and 9/16".
- One 3/8"-drive reversible ratchet: 7-7/8" long.
- Two extensions: 3" and 5" long.
- One 9/16" combination wrench: 6-5/8" long.
- One 3/16" hex nut driver.
- Hinged metal box.

Cat. No.	Description	Weight (lbs.)
65503	complete 9-piece "D" wrench kit plus metal box	3.60

12-Piece 3/8-Inch Drive Socket Wrench Set



Set consists of the following pieces:

- Four 6-point sockets: 3/8", 7/16", 1/2", and 9/16".
- Four 12-point sockets: 5/8", 11/16", 3/4", and 13/16".
- One spark plug socket: 5/8".
- Two extensions: 1-3/4" and 6" long.
- One ratchet.
- Hinged metal box.

Cat. No.	Description	Weight (lbs.)
65504	complete 12-piece 3/8" drive set plus metal box	3.62

13-Piece 3/8-Inch Drive Socket Set – Metric



65506

Set consists of the following pieces:

- Thirteen 6-point sockets: 7, 8, 9, 10, 11, 12, 13, 14, 15, 16, 17, 18, and 19 mm.
- Handy, flip-lock tray.

Cat. No.	Description	Weight (lbs.)
65506	13 sockets plus flip-lock tray	1.33

20-Piece 3/8-Inch Drive Socket Wrench Set



65508

Set consists of the following pieces:

- Four 6-point sockets: 3/8", 7/16", 1/2", and 9/16".
- Five 12-point sockets: 5/8", 11/16", 3/4", 13/16", and 7/8".
- Eight 6-point deep sockets: 3/8", 7/16", 1/2", 9/16", 5/8", 11/16", 3/4", and 13/16".
- Two extensions: 1-3/4", and 3" long.
- One ratchet.
- Hinged metal box.

Cat. No.	Description	Weight (lbs.)
65508	complete 20-piece 3/8" drive set plus metal box	5.40

All dimensions are in inches and (millimeters).

▲WARNING: Always wear approved eye protection.



Socket Wrench Sets

13-Piece 1/4-Inch Drive Socket Wrench Set

Set consists of the following pieces:

- Nine 6-point sockets: 3/16", 7/32", 1/4", 9/32", 5/16", 11/32", 3/8", 7/16", and 1/2".
- One spinner handle.
- Two extensions: 2" and 6" long.
- One ratchet.
- Hinged metal box.



65500

Cat. No.	Description	Weight (lbs.)
65500	complete 13-piece 1/4" drive set plus metal box	2.07

Socket Wrenches

1/4-Inch Drive – Standard 6-Point Sockets

Cat. No.	Size	Weight (lbs.)
65600	3/16"	.02
65601	7/32"	.02
65602	1/4"	.02
65603	9/32"	.02
65604	5/16"	.02
65605	11/32"	.03
65606	3/8"	.04
65607	7/16"	.04
65608	1/2"	.05



65604

1/4-Inch Drive – Deep 6-Point Sockets

Cat. No.	Size	Weight (lbs.)
65610	1/4"	.06
65611	9/32"	.06
65612	5/16"	.05
65613	11/32"	.07
65614	3/8"	.08
65615	7/16"	.09
65616	1/2"	.11



65615

1/4-Inch Drivers and Extensions

Cat. No.	Description	Weight (lbs.)
65620	4-3/4" ratchet	.32
65621	spinner handle	.19
65622	2" extension	.05
65623	6" extension	.14



65622



65620



65623



65621

3/8-Inch Drive – Standard 12-Point Sockets

Cat. No.	Size	Weight (lbs.)
65704	5/8"	.08
65705	11/16"	.11
65706	3/4"	.12
65707	13/16"	.15
65708	7/8"	.19



65706

3/8-Inch Drive – Standard 6-Point Sockets

Cat. No.	Size	Weight (lbs.)
65700	3/8"	.05
65701	7/16"	.05
65702	1/2"	.06
65703	9/16"	.06



65702



3/8-Inch Drive – Metric 6-Point Sockets

Cat. No.	Size	Weight (lbs.)
65907	7 mm	.04
65908	8 mm	.04
65909	9 mm	.05
65910	10 mm	.05
65911	11 mm	.05
65912	12 mm	.06
65913	13 mm	.07
65914	14 mm	.08
65915	15 mm	.10
65916	16 mm	.09
65917	17 mm	.10
65918	18 mm	.11
65919	19 mm	.14



3/8-Inch Drive – Deep 6-Point Sockets

Cat. No.	Size	Weight (lbs.)
65710	3/8"	.09
65711	7/16"	.10
65712	1/2"	.13
65713	9/16"	.15
65714	5/8"	.22
65715	11/16"	.27
65716	3/4"	.28
65717	13/16"	.34



3/8-Inch Drivers and Extensions

Cat. No.	Description	Weight (lbs.)
65720	7-1/2" ratchet	.73
65721	1-3/4" extension	.09
65722	3" extension	.15
65723	6" extension	.30
65724	5/8" spark plug socket	.21

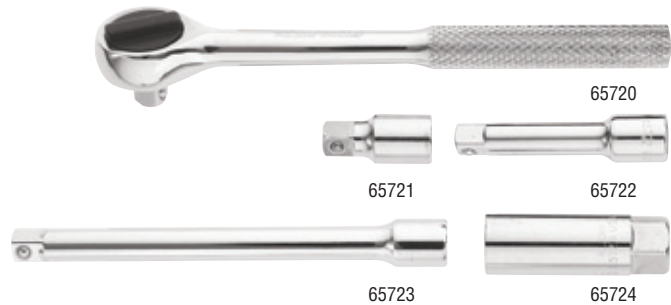

1/2-Inch Drive – Standard 12-Point Sockets

Cat. No.	Size	Weight (lbs.)
65800	7/16"	.12
65801	1/2"	.12
65802	9/16"	.12
65803	5/8"	.12
65804	11/16"	.16
65805	3/4"	.18
65806	13/16"	.19
65807	7/8"	.21
65808	15/16"	.27
65809	1"	.31
65810	1-1/16"	.36
65811	1-1/8"	.41
65812	1-1/4"	.55



1/2-Inch Drive – Deep 12-Point Sockets

Cat. No.	Size	Weight (lbs.)
65825	1/2"	.30
65826	9/16"	.31
65827	5/8"	.24
65828	11/16"	.32
65829	3/4"	.36
65830	13/16"	.41
65831	7/8"	.41
65832	15/16"	.55



1/2-Inch Drivers and Extensions

Cat. No.	Description	Weight (lbs.)
65820	10-1/2" ratchet	1.30
65821	5" extension	.45
65822	17" flex handle	1.83
65823	5/8" spark plug socket	.18

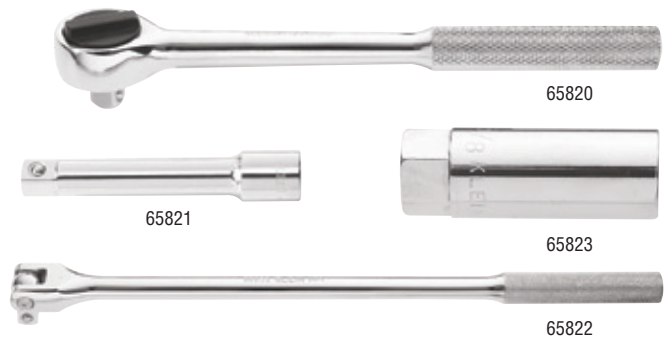

All dimensions are in inches and (millimeters).

▲WARNING: Always wear approved eye protection.



Ratcheting Box Wrenches

Features:

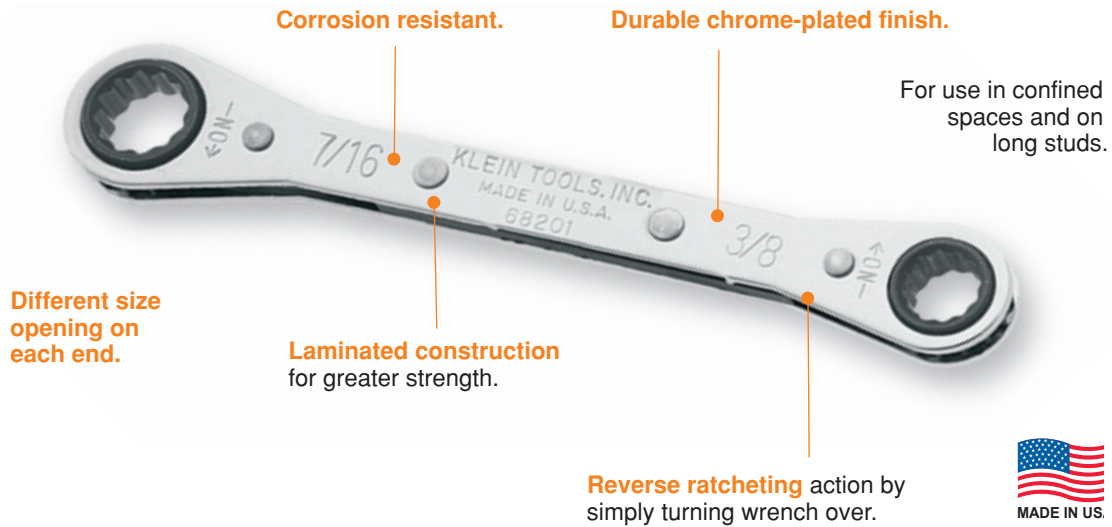

5-Piece Ratcheting Box Wrench Set

Additional Features:

- Five ratcheting box wrenches packed in a vinyl 8-1/2"W x 10"H (216 mm x 254 mm) roll-up pouch with individual pockets.
- Wrenches flip over to reverse ratchet.

Cat. No.	Set Contains	Weight (lbs.)	
68221		1.45	
Cat. No.	Point	Size	Length
68200	12	1/4" x 5/16"	4-3/8" (112 mm)
68201	12	3/8" x 7/16"	5-1/2" (140 mm)
68202	12	1/2" x 9/16"	6-7/8" (175 mm)
68203	12	5/8" x 11/16"	8-1/4" (216 mm)
68204	12	5/8" x 3/4"	8-1/4" (216 mm)



7-Piece Ratcheting Box Wrench Set

Additional Feature:

- Set of the ratcheting box wrenches in vinyl roll-up pouch.

Cat. No.	Set Contains	Weight (lbs.)	
68222		2.65	
Cat. No.	Point	Size	Length
68200	12	1/4" x 5/16"	4-3/8" (112 mm)
68201	12	3/8" x 7/16"	5-1/2" (140 mm)
68202	12	1/2" x 9/16"	6-7/8" (175 mm)
68203	12	5/8" x 11/16"	8-1/4" (216 mm)
68204	12	5/8" x 3/4"	8-1/4" (216 mm)
68205	12	11/16" x 3/4"	9-1/4" (235 mm)
68206	12	13/16" x 7/8"	9-1/4" (235 mm)



All dimensions are in inches and (millimeters).

▲WARNING: Always wear approved eye protection.

▲WARNING: Do NOT push or hammer wrench.

▲WARNING: Never use on or near live electrical circuits.

▲WARNING: Do NOT extend handle length.



Ratcheting Box Wrenches

Ratcheting Box Wrenches

Cat. No.	Point	Size	Length	Weight (lbs.)
68200	12	1/4" x 5/16"	4-3/8" (112 mm)	.13
68201	12	3/8" x 7/16"	5-1/2" (140 mm)	.18
68202	12	1/2" x 9/16"	6-7/8" (175 mm)	.29
68203	12	5/8" x 11/16"	8-1/4" (216 mm)	.43
68204	12	5/8" x 3/4"	8-1/4" (216 mm)	.42
68205	12	11/16" x 3/4"	9-1/4" (235 mm)	.52
68206	12	13/16" x 7/8"	9-1/4" (235 mm)	.69



68201

Ratcheting Offset Box Wrenches

3-Piece Fully Reversible Ratcheting Offset Box Wrench Set

- Set of three offset and fully reversible ratcheting box wrenches.
- Different size single-hex openings on each end.
- Includes heavy-duty vinyl pouch.

Cat. No.	Set Contains	Weight (lbs.)
68244		.61

Cat. No.	Point	Size	Length
68234	6	1/4" x 5/16"	4-3/8" (112 mm)
68236	6	3/8" x 7/16"	5-1/2" (140 mm)
68238	6	1/2" x 9/16"	6-3/4" (171 mm)



68244

5-Piece Fully Reversible Ratcheting Offset Box Wrench Set

- Set of the offset reversible ratchet box wrenches in vinyl roll-up pouch.
- Two grommet holes for hanging.

Cat. No.	Set Contains	Weight (lbs.)
68245		1.57

Cat. No.	Point	Size	Length
68234	6	1/4" x 5/16"	4-3/8" (112 mm)
68236	6	3/8" x 7/16"	5-1/2" (140 mm)
68238	6	1/2" x 9/16"	6-3/4" (171 mm)
68240	12	5/8" x 11/16"	8-1/8" (206 mm)
68242	12	3/4" x 7/8"	9-1/8" (232 mm)



68245

Fully Reversible Ratcheting Offset Box Wrenches

- Both ends are offset 25° for more convenient use in confined spaces.
- Quick-flip reversing lever for instant ratchet reversal.
- Laminated construction for greater strength.
- Chrome-plated for rust resistance.
- Different size openings at each end.

Cat. No.	Point	Size	Length	Weight (lbs.)
68234	6	1/4" x 5/16"	4-3/8" (112 mm)	.13
68236	6	3/8" x 7/16"	5-1/2" (140 mm)	.18
68238	6	1/2" x 9/16"	6-3/4" (171 mm)	.30
68240	12	5/8" x 11/16"	8-1/8" (206 mm)	.46
68242	12	3/4" x 7/8"	9-1/8" (232 mm)	.50



68236

All dimensions are in inches and (millimeters).

▲WARNING: Always wear approved eye protection.

▲WARNING: Do NOT push or hammer wrench.

▲WARNING: Never use on or near live electrical circuits.

▲WARNING: Do NOT extend handle length.



Ratcheting Offset Box Wrenches

Ratcheting Refrigeration Wrenches

- Fully reversible ratchet wrenches designed for refrigeration packing gland nuts and valve stem sockets.
- Wrenches are compact in size, with clearly marked sockets for four nut sizes.
- Also designed for beam-clamp installation.
- Quick-flip reversing lever permits instant ratchet reversal.
- Wrenches are ruggedly built and have polished chrome finish with smooth edges for comfort.



68310

Cat. No.	Socket Sizes	Length	Weight (lbs.)
68309	3/16" and 1/4" sq. x 1/2" and 9/16" hex	6-13/16" (173 mm)	.43
68310	3/16" and 5/16" sq. x 1/4" and 3/8" sq.	5-1/2" (140 mm)	.20
68310-24	24 pack of Cat. No. 68310	5-1/2" (140 mm)	4.70

Specialty Wrenches

Can Wrench

- Two tools in one; saves space in your pouch.
- One end opens telephone box fasteners, the other end tightens nuts on binding-post terminals.
- The 7/16" socket has a black finish and the 3/8" socket has a silver finish.
- Sockets are 1-1/4" (32 mm) deep to fit over long binding posts and are thin-walled for easy access into tight areas.
- Socket ends are color-coded for quick identification of socket sizes.



68005

- Hex-socket design enables using a wrench to obtain extra torque.
- High-impact, break-resistant handle for long and dependable service.
- Sockets are heat-treated, alloy steel.

Cat. No.	Description	Length	Handle Dia.	Weight (lbs.)
68005	3/8" and 7/16" hex nut	7" (178 mm)	1" (25 mm)	.35

⚠WARNING: NOT insulated. Will NOT protect against electrical shock.

Bell System Type

- Similar to standard lineman's wrench, but with end openings sized to NEMA hardware specifications.
- Silver painted finish.



3146B

Cat. No.	Description	Length	Weight (lbs.)
3146B	Large end has 1-1/16" and 1-3/16" openings. Small end has 11/16" and 7/8" openings.	13" (330 mm)	1.76

Ratcheting Lineman's Wrenches

- Bolt-through design allows bolts to pass through the socket.
- 3/4" and 1" x 1-1/8" combination square socket for most common utility hardware.
- Bright yellow socket for easy visibility.
- Works on most common utility pole hardware, such as lag bolts, "C" clamps and suspension bolts.



KT151T



KT155T

Cat. No.	Description	Length	Weight (lbs.)
KT151T	Ratcheting Lineman's Wrench	13"	2.12
KT155T	5-in-1 Lineman's Wrench	9-3/8"	1.42

- KT155T also offers two popular wrench sizes: 9/16" and 3/4".

Lineman's Box Wrenches

- "See-through handle" (Klein Klear-Vu™ technology) shows metal ends are not connected.
- 12-point 9/16" and 3/4" sockets.
- Reverse ratcheting action by simply turning wrench over.
- Textured grooves in handle prevent slipping (Cat. No. KT223-INS).

NEW!



KT223-INS



KT203

Cat. No.	Description	Socket Size	Length	Weight (lbs.)
KT223-INS	Insulating Lineman's Box Wrench	9/16" x 3/4"	8-1/4" (216 mm)	.62
KT203	Lineman's Box Wrench	9/16" x 3/4"	8-1/8" (206 mm)	.55

- Solid, one piece design. (Cat. No. KT203).
- Chrome plated finish resists corrosion.

All dimensions are in inches and (millimeters).

⚠WARNING: Always wear approved eye protection.

⚠WARNING: Never use on or near live electrical circuits.

⚠WARNING: Do NOT push or hammer wrench.

⚠WARNING: Do NOT extend handle length.



Lineman's Wrenches

- Forged from special bar steel and heat-treated for long life.
- Each end has two different size openings.
- Hole is provided at larger end for turning-in standard pole steps.
- Wrench is suited for use on heavy three-bolt guy clamps on which clearance is limited.
- Dark blue painted finish (small end is painted silver on Cat. No. 3146A).



3146

Cat. No.	Description	Length	Weight (lbs.)
3146	For 5/8" hardware. Large end has 29/32" and 1-3/32" openings. Small end has 5/8" and 13/16" openings.	13" (330 mm)	1.85
3146A	For 3/4" hardware. Large end has 1-1/16" and 1-5/16" openings. Small end has 5/8" and 7/8" openings.	13" (330 mm)	1.70

Construction Wrenches

Adjustable-Head Construction Wrench

- Versatile wrench fits nuts and bolts to 1-1/2" (38 mm).
- Eliminates the need for carrying several fixed-size wrenches.
- Forged from select alloy steel with continuous-taper handle for aligning bolt and/or rivet holes.
- Industrial black finish for corrosion resistance.



3239

Cat. No.	Max. Size Capacity	Length	Weight (lbs.)
3239	1-1/2" (38 mm)	16" (406 mm)	2.36

1/2"-Drive Ratcheting Construction Wrench

- Accepts 1/2" square-drive hex socket.
- Reversible ratchet.
- Eliminates the need for carrying several fixed-size wrenches.
- Forged from select alloy steel with continuous-taper handle for aligning bolt and/or rivet holes.
- Industrial black finish for corrosion resistance.



3238

Cat. No.	Overall Length	Weight (lbs.)
3238	15" (381 mm)	2.10

Erection Wrenches

- Forged from select alloy steel to withstand high-leverage and heavy loads.
- Extra-heavy-duty head area gives maximum strength and durability.
- Continuous taper of handle makes lining-up bolt holes easy and works on a range of bolt-hole sizes without binding.
- Extra-large hub area works on larger diameter holes better than other wrenches.
- Catalog number, bolt size and nominal opening size are stamped on every wrench for easy identification.
- American Bridge design.



3231

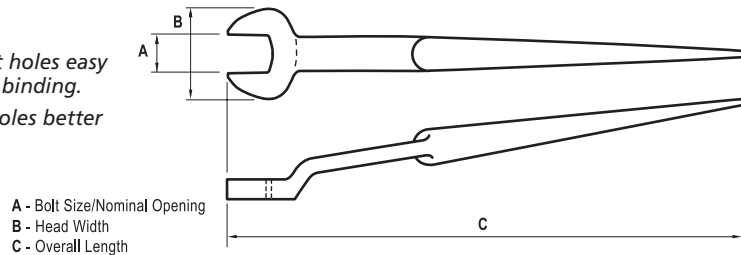

Cat. No.	Nut Type	Bolt Size	Nom. Opening	Head Width	Taper Diameter	Overall Length	Weight (lbs.)
3210	U.S. heavy	1/2"	7/8"	2-1/4"	7/8" to 3/16"	14-3/4"	1.36
3211	U.S. heavy	5/8"	1-1/16"	2-1/4"	7/8" to 3/16"	14-3/4"	1.31
3212	U.S. heavy	3/4"	1-1/4"	2-1/2"	1" to 1/4"	16-5/8"	1.98
3213	U.S. heavy	7/8"	1-7/16"	3"	1-1/8" to 9/32"	17-3/8"	2.72
3214	U.S. heavy	1"	1-5/8"	3-5/8"	1-1/8" to 1/4"	18"	3.36
3219	U.S. regular	1/2"	3/4"	2-1/4"	7/8" to 8/16"	14-3/4"	1.36
3220	U.S. regular	1/2"	13/16"	2-1/4"	7/8" to 3/16"	14-3/4"	1.35

Cat. No.	Nut Type	Bolt Size	Nom. Opening	Head Width	Taper Diameter	Overall Length	Weight (lbs.)
3221	U.S. regular	5/8"	1"	2-1/4"	7/8" to 3/16"	14-3/4"	1.31
3222	U.S. regular	3/4"	1-1/8"	2-1/2"	1" to 1/4"	16-5/8"	2.00
3223	U.S. regular	7/8"	1-5/16"	3"	1-1/8" to 9/32"	17-3/8"	2.87
3224	U.S. regular	1"	1-1/2"	3-5/8"	1-1/8" to 1/4"	18"	3.37
3231	utility	5/8"	15/16"	2-1/4"	7/8" to 3/16"	14-3/4"	1.31
3232	utility	3/4"	1-1/16"	2-1/2"	1" to 1/4"	16-5/8"	2.00

All dimensions are in inches and (millimeters).

▲WARNING: Always wear approved eye protection.

▲WARNING: Do NOT push or hammer wrench.

▲WARNING: Do NOT extend handle length.



Strap Wrenches

Grip-It® Strap Wrenches

- Completely adjustable strap wrench.
- Works in the tightest quarters.
- Urethane-covered, high-strength belting attached to lightweight, I-beam handle.
- Patented, cam-action design permits uniform, high-torque application.
- Under normal conditions, will not scratch, damage or deform polished pipe and fittings, plastic pipe and fittings, oil and water filters, glass pipe, PVC conduit, or polished shafts.
- Also works on alternator belts, flywheels, and propeller assemblies.



S12H

Cat. No.	Handle Length	Diameter Capacity, O.D.	Weight (lbs.)
S6H	6" (152 mm)	1-1/2" – 5" (38 mm – 127 mm)	.20
S12H	12" (305 mm)	1-1/2" – 5" (38 mm – 127 mm)	.80
S18H	18" (457 mm)	1-1/8" – 8" (28 mm – 228 mm)	2.95

Torque Wrenches

Micro-Adjustable Torque-Sensing Wrenches with Square-Drive Ratchet Head

- Automatically limits desired torque.
- "Torque by feel." Pull and click—it's torqued to micrometer accuracy.
- Ratchet head allows speedy torquing and operation in confined working areas.
- Torques to the right.



57005

Cat. No.	Drive Size	Range	Length	Weight (lbs.)
57000	3/8"	15 – 75 ft-lb (20.4 – 101.7 Nm)	14-1/8" (359 mm)	2.00
57005	3/8"	30 – 150 in-lb (3.4 – 16.9 Nm)	10-5/8" (270 mm)	1.20
57010	1/2"	50 – 250 ft-lb (67.8 – 339.0 Nm)	24-1/4" (616 mm)	3.65

Master Electrician's Torque Tool Kit

- Two micrometer-adjustable torque wrenches.
- Nine hex-wrench bits.
- Two 7/16" hex-wrench extensions.
- One 7/16" female hex-wrench adaptor (Coupler).
- One hex-to-square adapter for wrenches and one adaptor for screwdrivers.
- One adjustable torque screwdriver.
- Seven screwdriver bits; five slotted, two Phillips.
- Hinged metal box.
- Additional torque screwdrivers available in screwdriver section.



57060

Cat. No.	Description	Weight (lbs.)
57060	master electrician's torque tool kit	9.55

All dimensions are in inches and (millimeters).

▲WARNING: Always wear approved eye protection.

▲WARNING: Do NOT push or hammer wrench.

▲WARNING: Do NOT extend handle length.

