

MICRO compound table KT 70

Made of solid aluminium with surface treatment and fitted with adjustable dovetail gibs and three T-slots of the MICROMOT standard (12 x 6 x 5mm). Adjustable ruler eases workpiece positioning. Both handwheels have zero-resettable dials with graduations indicating 1 revolution = 1.0mm and 1 division = 0.05mm. The clamps and securing bolts for the MB 140/S and TBM are included.

General details:

Table size 200 x 70mm. X travel 134mm and Y travel 46mm, maximum height 43mm.

No 27 100

Step clamps made of steel

The step clamps set is supplied with the KT 70, but can also be ordered separately. Set consists of 2 ea. stepped blocks and clamps, T-slot nuts of the MICROMOT standard (11.5 x 11 x 4mm), bolts. This set also fits the mill/lathe systems PD 230/E and PD 400.

No 24 256

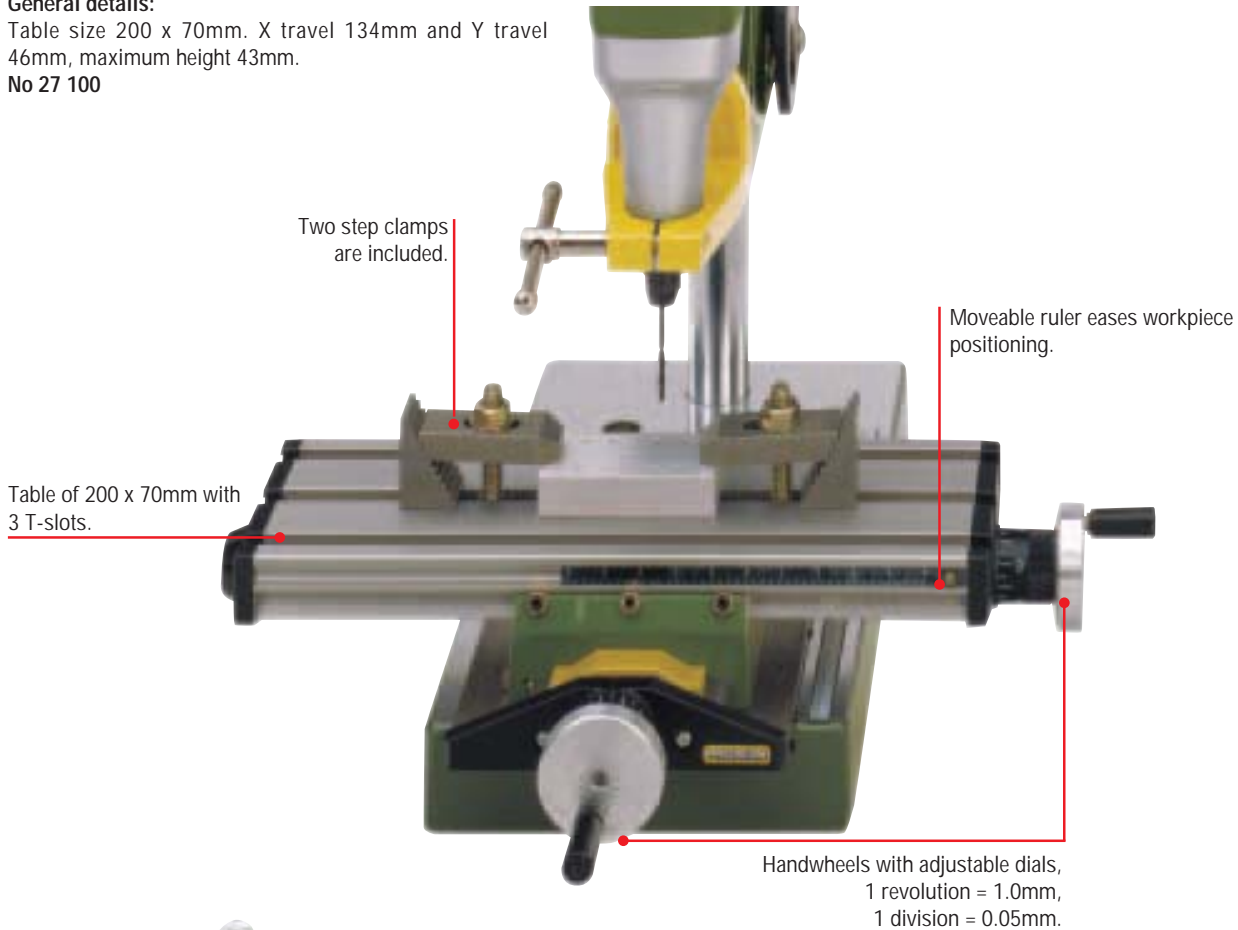

Table of 200 x 70mm with 3 T-slots.

Two step clamps are included.

Moveable ruler eases workpiece positioning.

Handwheels with adjustable dials,
1 revolution = 1.0mm,
1 division = 0.05mm.



Precision vise FMZ *With integral clamp.*

Easily clamps to workbenches and tables of up to 60mm. Alternatively, use 2 standard screws to secure to the work surface. Zinc die-casting with ball and socket: rotates in all directions (even downwards). 75mm jaws with protective covers (for delicate workpieces). Jaws also with vertical and horizontal V-slots for clamping round workpieces. Maximum clamping width 70mm and weight 1.6kg.

No 28 608

Precision vise FMS 75

As detailed above, but without clamp. A strong suction cup facilitates instantaneous fixing to any smooth, flat surface.

No 28 602

