

Vision-Lite® Professional Magnifier

Exclusive “Patented” Dimmable Fluorescent Illuminated Magnifier



71600



71600-BG

- ESD Safe
- **RoHS Compliant**
- Dimmable from 100% Down To 25% with fingertip control
- Exclusive **Full Spectrum** Lighting for **Lead-Free** Soldering
- The Largest and Clearest 7.5” x 6.2” Crown White Optical Glass
- **NEW, FREE** 10 Diopter Add-on Lens to Boost Magnification Power
- Ergonomic Design for Maximum Comfort, Safety and Productivity
- Rigid Assembly and Inspection Standards
- Exclusive 10 year Lifetime Warranty
- Optional **Anti-Reflective** Coating to Reduce Overhead Glare (add “-AR” to part number)
- 120 Volt UL / cUL
- 230 Volt Available (CE)
- Many mounting styles to choose from (table clamp, screw down, and weighted base *shown above*)



O.C. White Co.
4226 Church St.
Thorndike, MA
01079

Contact Information
Sales: 413-289-1751
Tech: (888) OCWHITE
Fax: 413-289-1754
Email: info@ocwhite.com



Technical Specifications

Power Requirement	120 volt (230 volt Available)
Color	Black, Black & Gold, Shadow White (Light Grey), or “Lead-Free” Green
RoHS Compliant	Yes
ESD Safe	Yes
Magnification	3 Diopter (1.75x); 4 Diopter Available (2x)
Warranty Period	10 Year Lifetime Mechanical; 1 Year Electrical
Approvals	UL / cUL & CE
Arm Reach	25” Overall Reach
Bulb Type	35 watt Fluorescent “U” Bulb with Rare Tri-Earth Phosphors
Color Temperature	5500° Kelvin Full Spectrum
Light Intensity	Fully Variable between 25 to 100%
Replacement Bulb	Only use OC White p/n 13392 “Full Spectrum Vision-Lite® Bulb”
Other Bulbs Available	13393 “Blacklight Blue” (UV) Bulb for Vision-Lite® 13395 “Yellow” (Photo Resist) Bulb for Vision-Lite®
Rated Service Life	“U” Bulb rated for 10,000 hours before replacement
Mounting	Weighted Base Assembly

Mechanical Specs

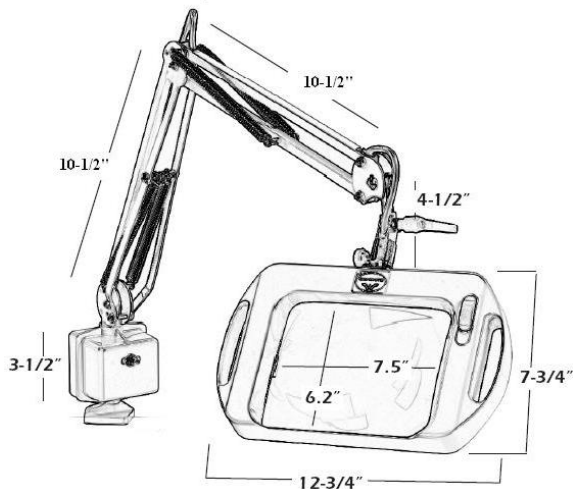

13226 Bulb Shield for Vision-Lite®

O.C. White Co.
4226 Church St.
Thorndike, MA
01079

Contact Information
Sales: 413-289-1751
Tech: (888) OCWHITE
Fax: 413-289-1754
Email: info@ocwhite.com

