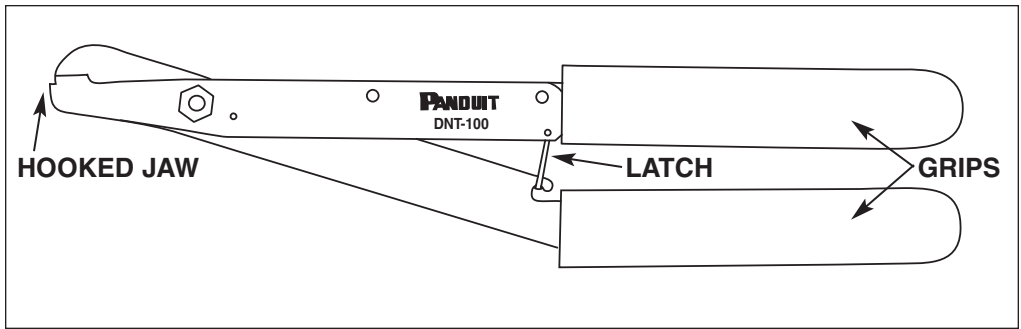

# DNT-100

## OPERATION INSTRUCTIONS

© Panduit Corp. 2005

# WIRE DUCT NOTCHING TOOL

**Part No. DNT-100****PANDUCT Plastic Wiring Duct**

### STEP 1

- Determine number of fingers (section) to be removed from duct.
- Insert hooked jaw (as shown) into the slot adjacent to the first finger to be removed.
- Seat hooked jaw into score line at base of duct.

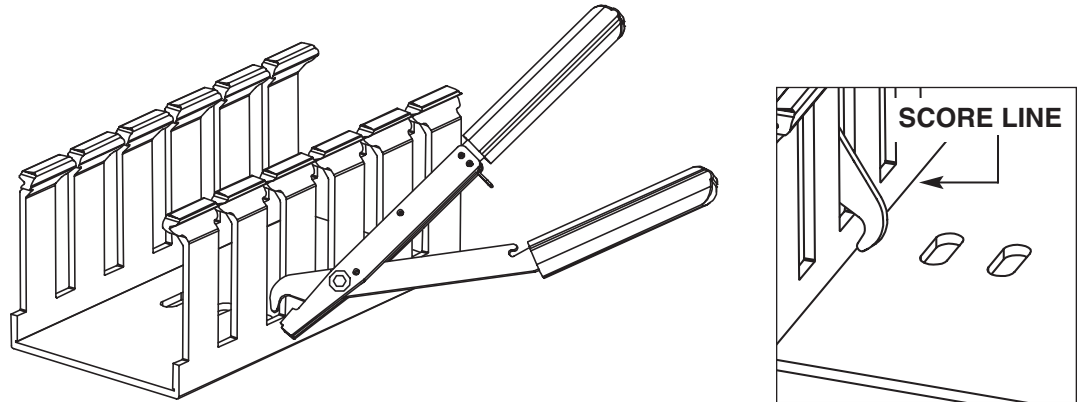

### STEP 2

- Close jaws to cut a slot next to the finger. Repeat at other side of section to be removed.  
(continued on Page 2)

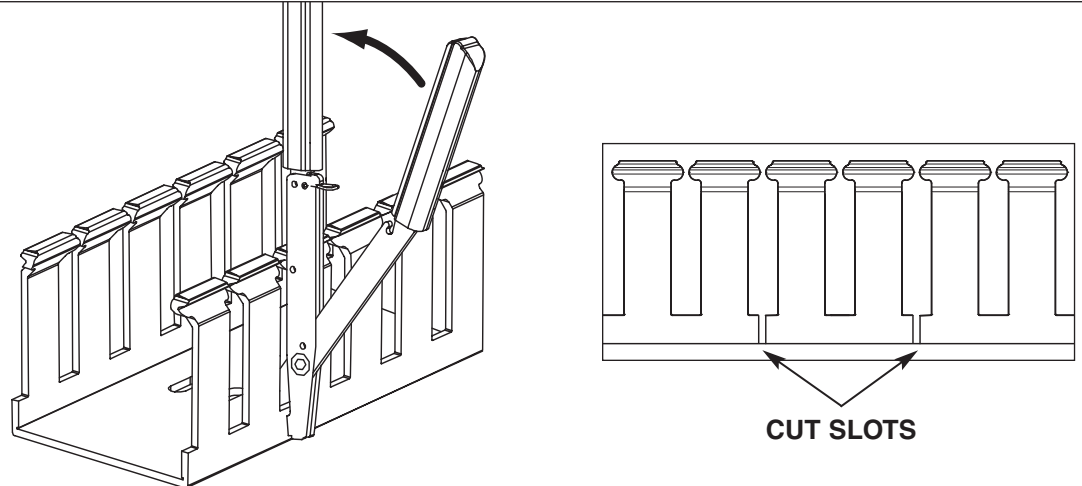

**TOOL MAINTENANCE:** This tool requires no special maintenance.

**NOTE:** This precision tool has been engineered and designed for use with *PANDUCT* Plastic Wiring Duct. It is not intended for use with other products or materials.

## STEP 3 - REMOVING SECTION

- 3.a. Bend section outward
- 3.b. Push down and fold at score line
- 3.c. Bend back inward
- 3.d. Bend back outward
- 3.e. Snap off at score line

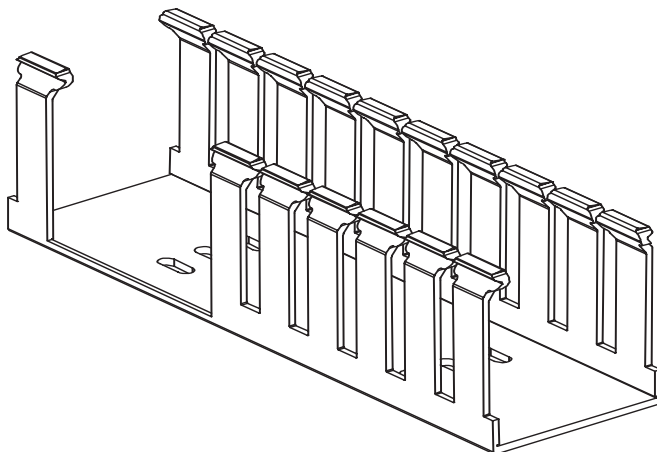
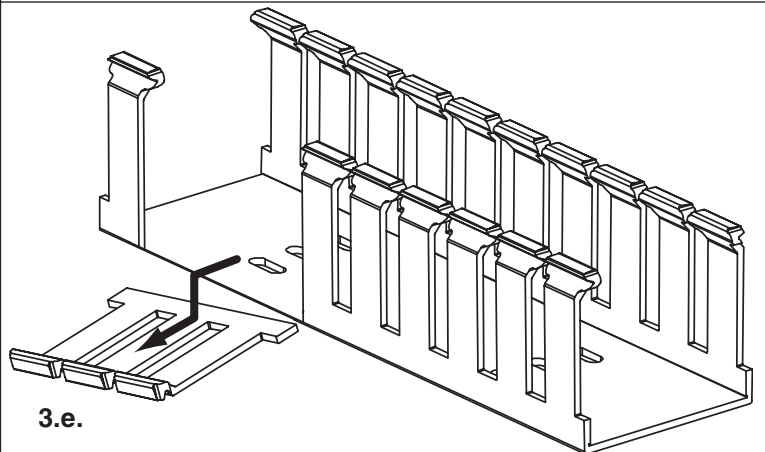
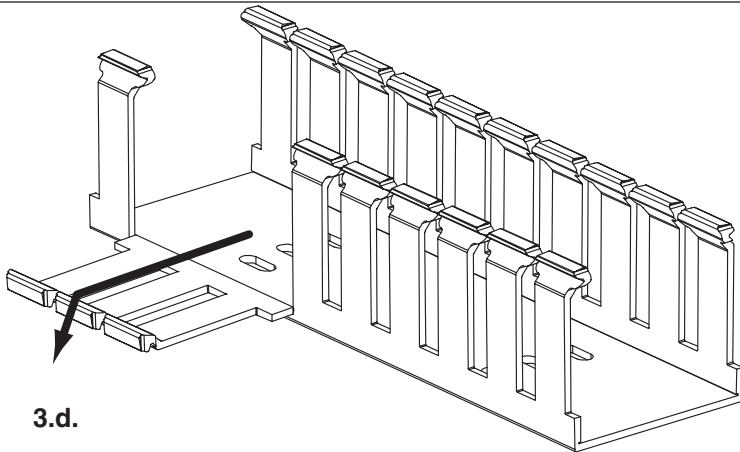
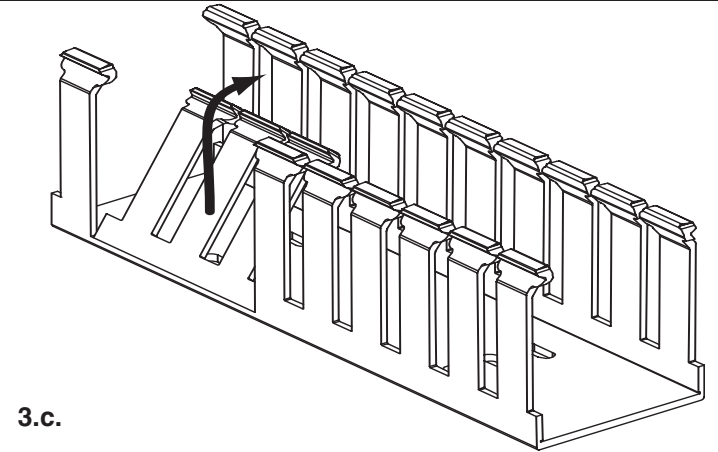
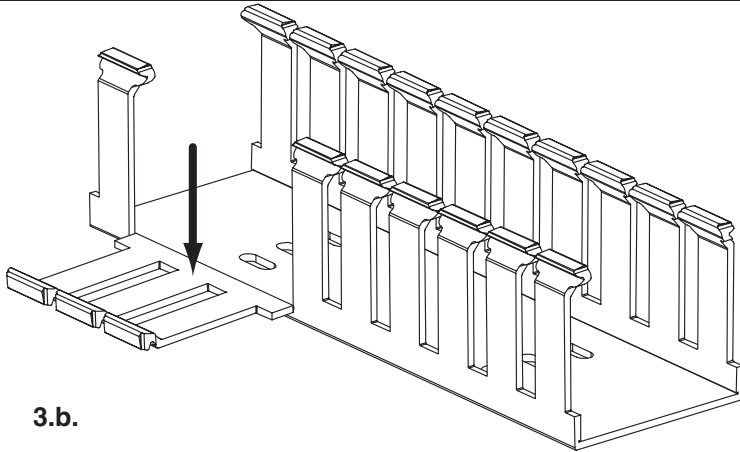
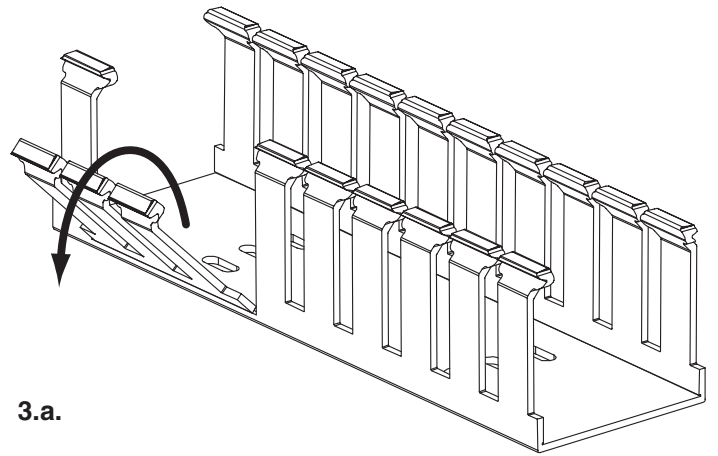

Leaves a smooth consistent edge.