

## 100 watt + 100 watt dual BTL class-D audio amplifier

### Features

- 100 W + 100 W output power at THD = 10% with  $R_L = 6 \Omega$  and  $V_{CC} = 36 V$
- 80 W + 80 W output power at THD = 10% with  $R_L = 8 \Omega$  and  $V_{CC} = 34 V$
- Wide range single supply operation (14 - 39 V)
- High efficiency ( $\eta = 90\%$ )
- Four selectable, fixed gain settings of nominally 25.6 dB, 31.6 dB, 35.1 dB and 37.6 dB
- Differential inputs minimize common-mode noise
- Standby and mute features
- Short-circuit protection
- Thermal overload protection
- Externally synchronizable

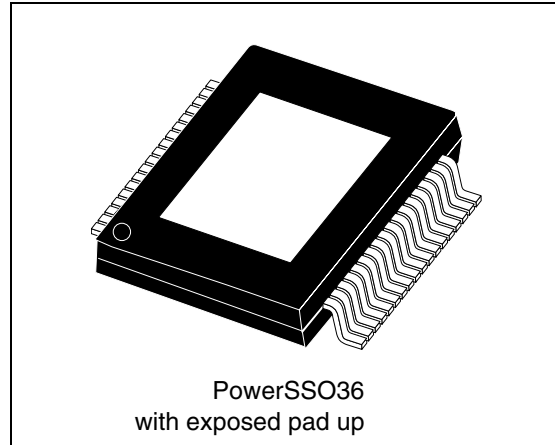

### Description

The TDA7498 is a dual BTL class-D audio amplifier with single power supply designed for home systems and active speaker applications.

It comes in a 36-pin PowerSSO package with exposed pad up (EPU) to facilitate mounting a separate heatsink.

**Table 1. Device summary**

Order code	Operating temp. range	Package	Packaging
TDA7498	-40 to 85 °C	PowerSSO36 (EPU)	Tube
TDA7498TR	-40 to 85 °C	PowerSSO36 (EPU)	Tape and reel

# Contents

<b>1</b>	<b>Device block diagram</b> .....	<b>5</b>
<b>2</b>	<b>Pin description</b> .....	<b>6</b>
2.1	Pin-out .....	6
2.2	Pin list .....	7
<b>3</b>	<b>Electrical specifications</b> .....	<b>8</b>
3.1	Absolute maximum ratings .....	8
3.2	Thermal data .....	8
3.3	Recommended operating conditions .....	8
3.4	Electrical specifications .....	8
<b>4</b>	<b>Characterization</b> .....	<b>11</b>
4.1	Test circuit .....	11
4.2	Characterization curves .....	13
4.2.1	For $R_L = 6 \Omega$ .....	13
4.2.2	For $R_L = 8 \Omega$ .....	16
<b>5</b>	<b>Applications information</b> .....	<b>19</b>
5.1	Applications circuit .....	19
5.2	Mode selection .....	20
5.3	Gain setting .....	21
5.4	Input resistance and capacitance .....	22
5.5	Internal and external clocks .....	23
5.5.1	Master mode (internal clock) .....	23
5.5.2	Slave mode (external clock) .....	23
5.6	Output low-pass filter .....	24
5.7	Protection function .....	25
5.8	Diagnostic output .....	25
<b>6</b>	<b>Package mechanical data</b> .....	<b>26</b>
<b>7</b>	<b>Revision history</b> .....	<b>28</b>

## List of Figures

Figure 1.	Internal block diagram (showing one channel only)	5
Figure 2.	Pin connection (top view, PCB view)	6
Figure 3.	Test circuit for characterizations	11
Figure 4.	Test board	12
Figure 5.	Output power (THD = 10%) vs. supply voltage	13
Figure 6.	THD vs. output power	13
Figure 7.	THD vs. frequency (1 W)	14
Figure 8.	THD vs. frequency (100 mW)	14
Figure 9.	Frequency response	14
Figure 10.	FFT performance (0 dBFS)	15
Figure 11.	FFT performance (-60 dBFS)	15
Figure 12.	Output power (THD = 10%) vs. supply voltage	16
Figure 13.	THD vs. output power	16
Figure 14.	THD vs. frequency (1 W)	17
Figure 15.	THD vs. frequency (100 mW)	17
Figure 16.	Frequency response	17
Figure 17.	FFT performance (0 dB)	18
Figure 18.	FFT performance (-60 dB)	18
Figure 19.	Applications circuit for 6-Ω speakers	19
Figure 20.	Applications circuit for 8-Ω speakers	20
Figure 21.	Standby and mute circuits	21
Figure 22.	Turn on/off sequence for minimizing speaker “pop”	21
Figure 23.	Input circuit and frequency response	22
Figure 24.	Master and slave connection	23
Figure 25.	Typical LC filter for a 8-Ω speaker	24
Figure 26.	Typical LC filter for a 6-Ω speaker	24
Figure 27.	Behavior of pin DIAG for various protection conditions	25
Figure 28.	PowerSSO36 EPU outline drawing	27

## List of Tables

Table 1.	Device summary . . . . .	1
Table 2.	Pin description list . . . . .	7
Table 3.	Absolute maximum ratings . . . . .	8
Table 4.	Thermal data . . . . .	8
Table 5.	Recommended operating conditions . . . . .	8
Table 6.	Electrical specifications . . . . .	8
Table 7.	Mode settings . . . . .	20
Table 8.	Gain settings . . . . .	21
Table 9.	How to set up SYNCLK . . . . .	23
Table 10.	PowerSSO36 EPU dimensions . . . . .	26
Table 11.	Document revision history . . . . .	28

# 1 Device block diagram

Figure 1 shows the block diagram of one of the two identical channels of the TDA7498.

Figure 1. Internal block diagram (showing one channel only)

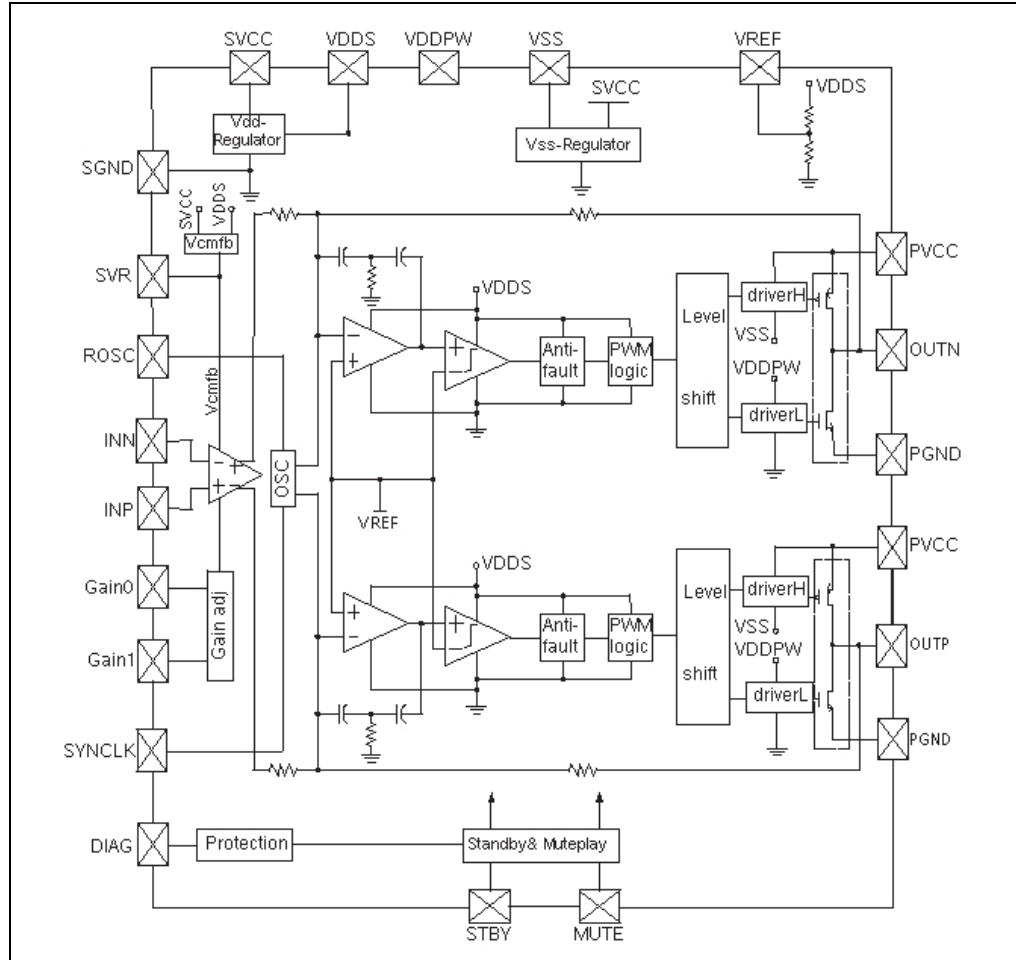

## 2 Pin description

### 2.1 Pin-out

Figure 2. Pin connection (top view, PCB view)

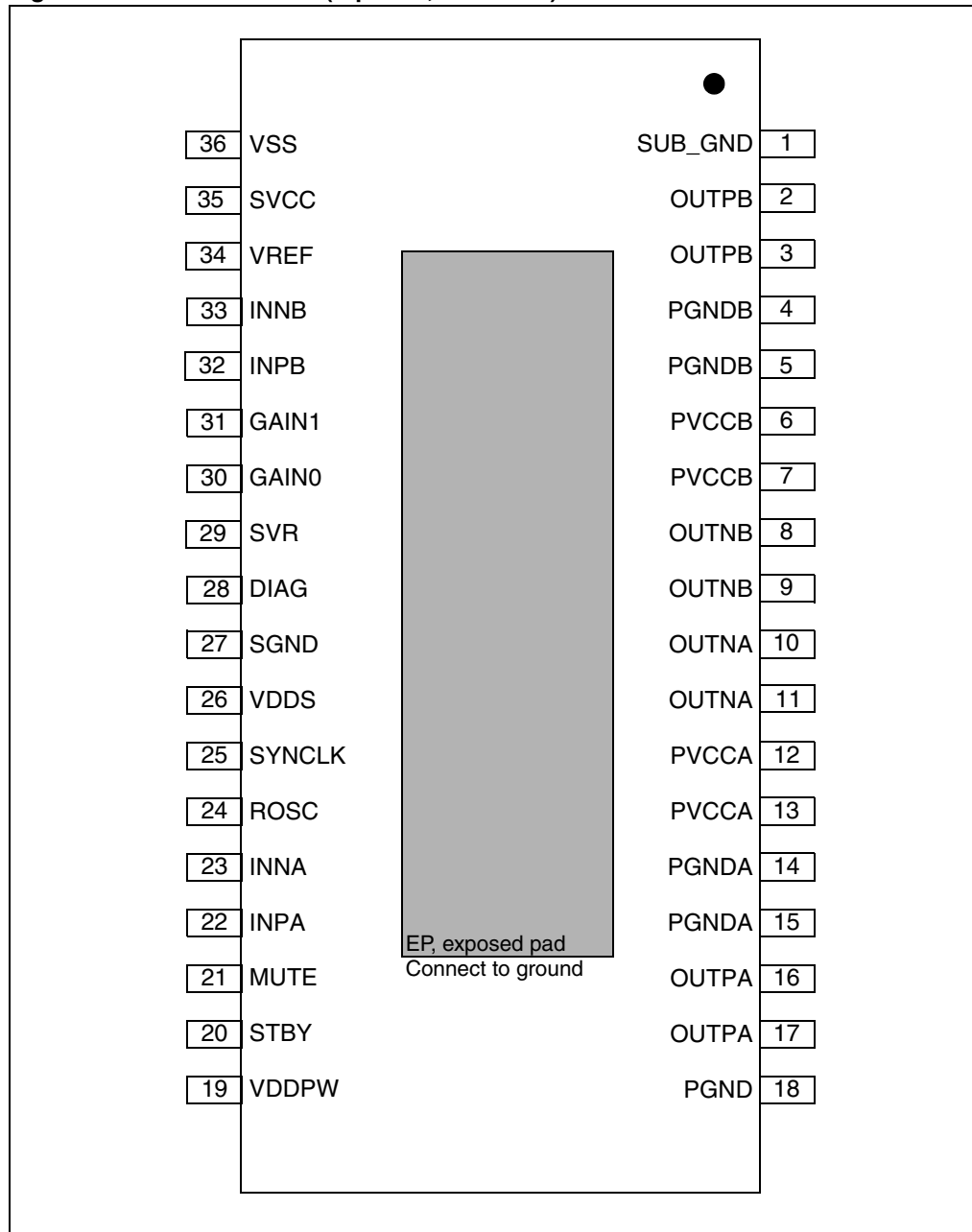

## 2.2 Pin list

**Table 2. Pin description list**

Number	Name	Type	Description
1	SUB_GND	PWR	Connect to the frame
2,3	OUTPB	O	Positive PWM for right channel
4,5	PGNDB	PWR	Power stage ground for right channel
6,7	PVCCB	PWR	Power supply for right channel
8,9	OUTNB	O	Negative PWM output for right channel
10,11	OUTNA	O	Negative PWM output for right channel
12,13	PVCCA	PWR	Power supply for left channel
14,15	PGNDA	PWR	Power stage ground for left channel
16,17	OUTPA	O	Positive PWM output for left channel
18	PGND	PWR	Power stage ground
19	VDDPW	O	3.3-V (nominal) regulator output referred to ground for power stage
20	STBY	I	Standby mode control
21	MUTE	I	Mute mode control
22	INPA	I	Positive differential input of left channel
23	INNA	I	Negative differential input of left channel
24	ROSC	O	Master oscillator frequency-setting pin
25	SYNCLK	I/O	Clock in/out for external oscillator
26	VDDS	O	3.3-V (nominal) regulator output referred to ground for signal blocks
27	SGND	PWR	Signal ground
28	DIAG	O	Open-drain diagnostic output
29	SVR	O	Supply voltage rejection
30	GAIN0	I	Gain setting input 1
31	GAIN1	I	Gain setting input 2
32	INPB	I	Positive differential input of right channel
33	INNB	I	Negative differential input of right channel
34	VREF	O	Half VDDS (nominal) referred to ground
35	SVCC	PWR	Signal power supply
36	VSS	O	3.3-V (nominal) regulator output referred to power supply
-	EP	-	Exposed pad for heatsink, to be connected to ground

### 3 Electrical specifications

#### 3.1 Absolute maximum ratings

Table 3. Absolute maximum ratings

Symbol	Parameter	Value	Unit
$V_{CC}$	DC supply voltage for pins PVCCA, PVCCB, SVCC	44	V
$V_I$	Voltage limits for input pins STBY, MUTE, INNA, INPA, INNB, INPB, GAIN0, GAIN1	-0.3 to 3.6	V
$T_j$	Operating junction temperature	-40 to 150	°C
$T_{stg}$	Storage temperature	-40 to 150	°C

#### 3.2 Thermal data

Table 4. Thermal data

Symbol	Parameter	Min	Typ	Max	Unit
$R_{th\ j-case}$	Thermal resistance, junction to case	-	2	3	°C/W

#### 3.3 Recommended operating conditions

Table 5. Recommended operating conditions

Symbol	Parameter	Min	Typ	Max	Unit
$V_{CC}$	Supply voltage for pins PVCCA, PVCCB, SVCC	14	-	39	V
$T_{amb}$	Ambient operating temperature	-40	-	85	°C

#### 3.4 Electrical specifications

Unless otherwise stated, the values in the table below are specified for the conditions:  
 $V_{CC} = 36\text{ V}$ ,  $R_L = 6\ \Omega$ ,  $R_{OSC} = R_3 = 39\text{ k}\Omega$ ,  $C_8 = 100\text{ nF}$ ,  $f = 1\text{ kHz}$ ,  $G_V = 25.6\text{ dB}$   
 $T_{amb} = 25\text{ °C}$ .

Table 6. Electrical specifications

Symbol	Parameter	Condition	Min	Typ	Max	Unit
$I_q$	Total quiescent current	No LC filter, no load	-	40	60	mA
$I_{qSTBY}$	Quiescent current in standby	-	-	1	10	$\mu\text{A}$
$V_{OS}$	Output offset voltage	Play mode	-100	-	100	mV
		Mute mode	-60	-	60	
$I_{OCP}$	Overcurrent protection threshold	$R_L = 0\ \Omega$	5.5	7	-	A



Table 6. Electrical specifications (continued)

Symbol	Parameter	Condition	Min	Typ	Max	Unit
$T_j$	Junction temperature at thermal shutdown	-	-	150	-	°C
$R_i$	Input resistance	Differential input	48	60	-	k $\Omega$
$V_{OVP}$	Overvoltage protection threshold	-	42	43	-	V
$V_{UVP}$	Undervoltage protection threshold	-	-	-	8	V
$R_{dsON}$	Power transistor on resistance	High side	-	0.2	-	$\Omega$
		Low side	-	0.2	-	
$P_o$	Output power	THD = 10%	-	100	-	W
		THD = 1%	-	78	-	
$P_o$	Output power	$R_L = 8 \Omega$ , THD = 10%	-	80	-	W
$P_D$	Dissipated power	$P_o = 100 \text{ W} + 100 \text{ W}$ , THD = 10%	-	20	-	W
$\eta$	Efficiency	$P_o = 100 \text{ W} + 100 \text{ W}$	-	90	-	%
THD	Total harmonic distortion	$P_o = 1 \text{ W}$	-	0.1	-	%
$G_V$	Closed-loop gain	GAIN0 = L, GAIN1 = L	24.6	25.6	26.6	dB
		GAIN0 = L, GAIN1 = H	30.6	31.6	32.6	
		GAIN0 = H, GAIN1 = L	34.1	35.1	36.1	
		GAIN0 = H, GAIN1 = H	36.6	37.6	38.6	
$\Delta G_V$	Gain matching	-	-1	-	1	dB
$C_T$	Crosstalk	$f = 1 \text{ kHz}$ , $P_o = 1 \text{ W}$	50	70	-	dB
eN	Total input noise	A Curve, $G_V = 20 \text{ dB}$	-	15	-	$\mu\text{V}$
		$f = 22 \text{ Hz to } 22 \text{ kHz}$	-	25	50	
SVRR	Supply voltage rejection ratio	$f_r = 100 \text{ Hz}$ , $V_r = 0.5 \text{ V}_{pp}$ , $C_{SVR} = 10 \mu\text{F}$	-	70	-	dB
$T_r, T_f$	Rise and fall times	-	-	50	-	ns
$f_{SW}$	Switching frequency	Internal oscillator	290	310	330	kHz
$f_{SWR}$	Output switching frequency range	With internal oscillator <sup>(1)</sup>	250	-	400	kHz
		With external oscillator <sup>(2)</sup>	250	-	400	
$V_{inH}$	Digital input high (H)	-	2.3	-	-	V
$V_{inL}$	Digital input low (L)		-	-	0.8	

**Table 6. Electrical specifications (continued)**

Symbol	Parameter	Condition	Min	Typ	Max	Unit
V <sub>STBY</sub>	Pin STBY voltage high (H)	-	2.7	-	-	V
	Pin STBY voltage low (L)		-	-	0.5	
V <sub>MUTE</sub>	Pin MUTE voltage high (H)	-	2.5	-	-	V
	Pin MUTE voltage low (L)		-	-	0.8	
A <sub>MUTE</sub>	Mute attenuation	V <sub>MUTE</sub> = L, V <sub>STBY</sub> = H	-	70	-	dB

- $f_{SW} = 10^6 / ((16 * R_{OSC} + 182) * 4)$  kHz,  $f_{SYNCLK} = 2 * f_{SW}$  with  $R3 = 39$  k $\Omega$  (see [Figure 19](#)).
- $f_{SW} = f_{SYNCLK} / 2$  with the external oscillator.

# 4 Characterization

## 4.1 Test circuit

Figure 3 shows the test circuit with which the characterization curves, shown in the next sections, were measured. Figure 4 shows the PCB layout.

Figure 3. Test circuit for characterizations

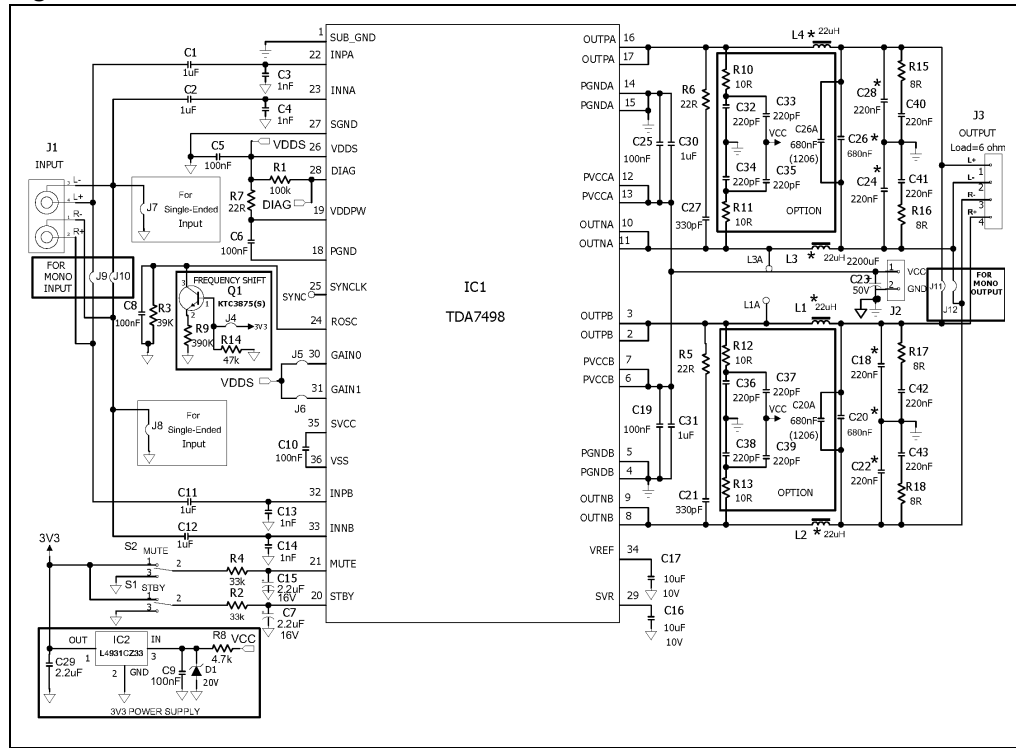
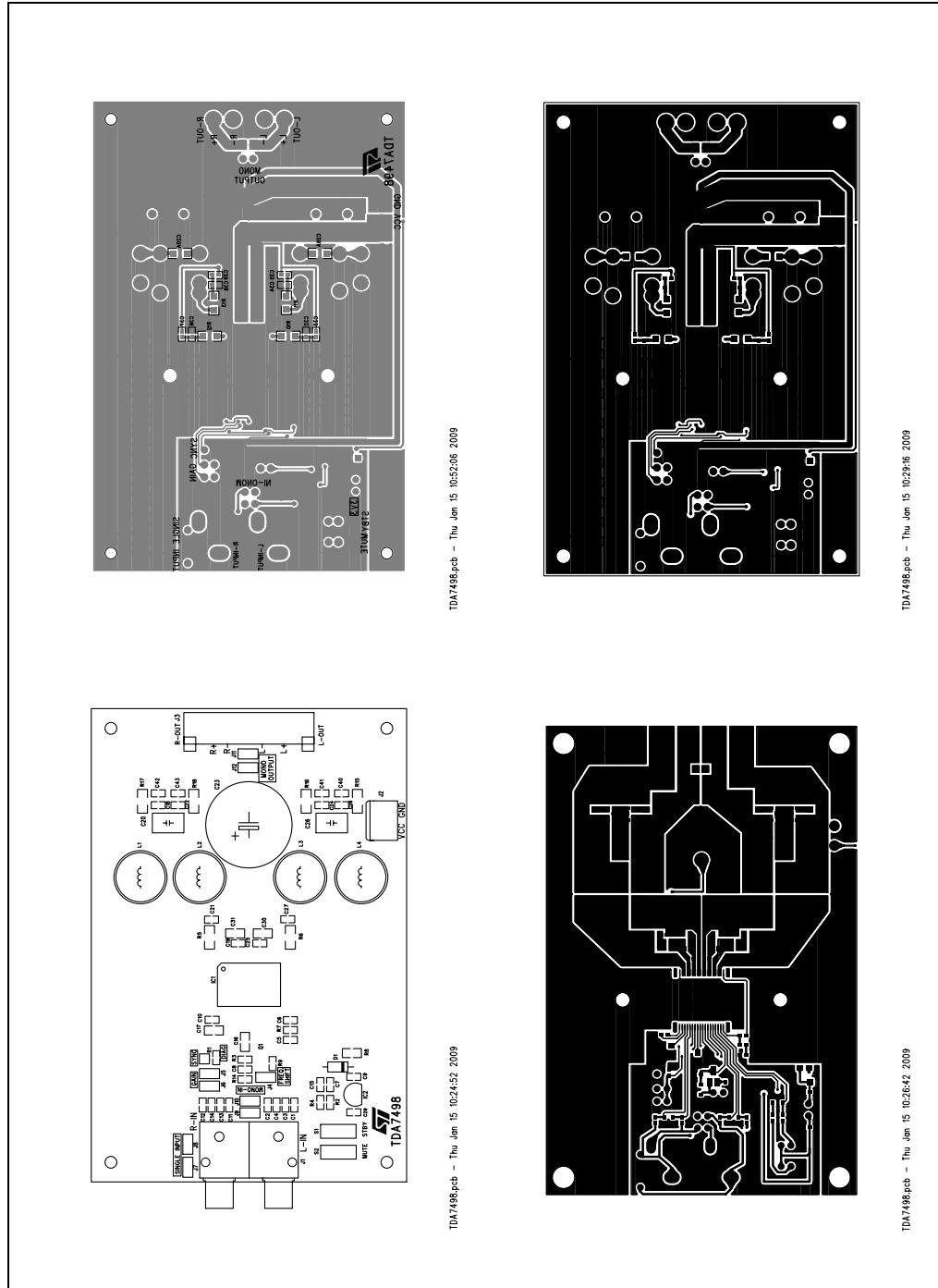

Figure 4. Test board



## 4.2 Characterization curves

Unless otherwise stated the measurements were made under the following conditions:

$V_{CC} = 36\text{ V}$ ,  $f = 1\text{ kHz}$ ,  $G_V = 25.6\text{ dB}$ ,  $R_{OSC} = 39\text{ k}\Omega$ ,  $C_{OSC} = 100\text{ nF}$ ,  $T_{amb} = 25\text{ }^\circ\text{C}$

### 4.2.1 For $R_L = 6\text{ }\Omega$

Figure 5. Output power (THD = 10%) vs. supply voltage

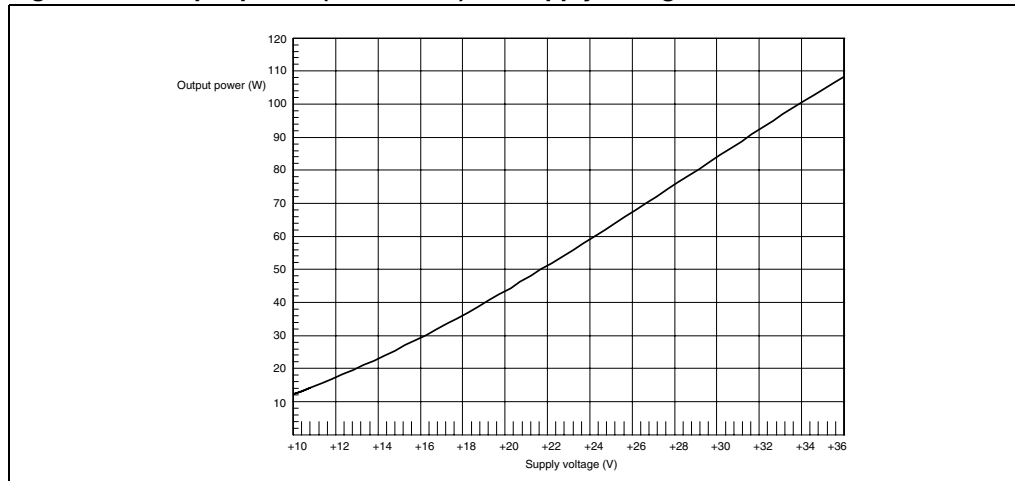

Figure 6. THD vs. output power

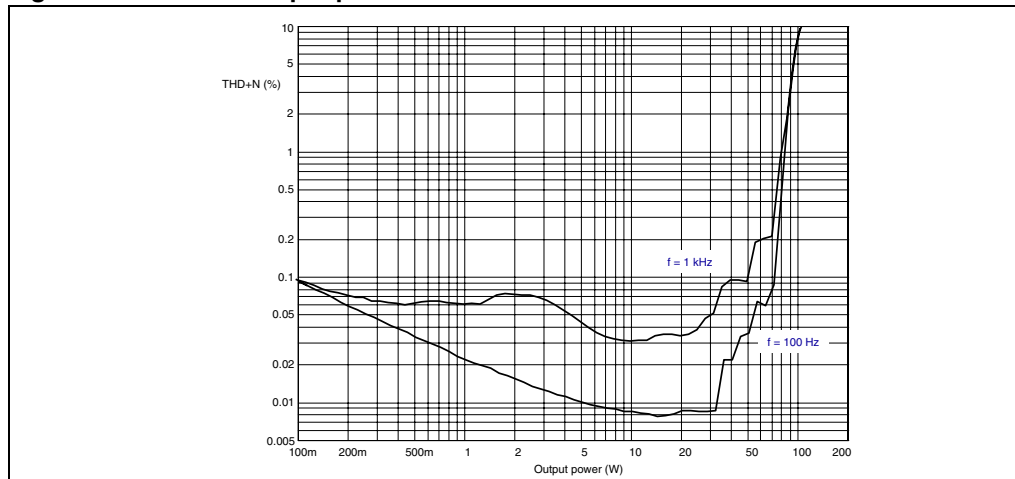

Figure 7. THD vs. frequency (1 W)

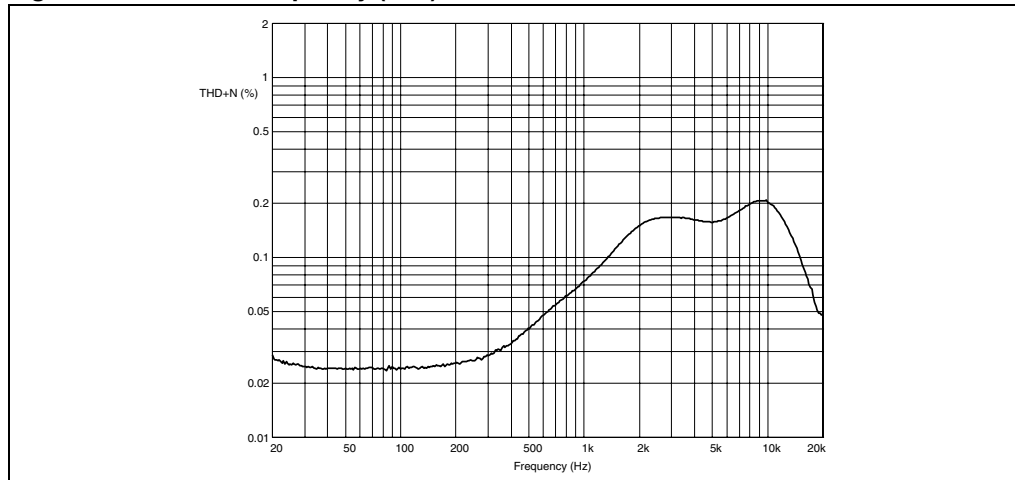

Figure 8. THD vs. frequency (100 mW)

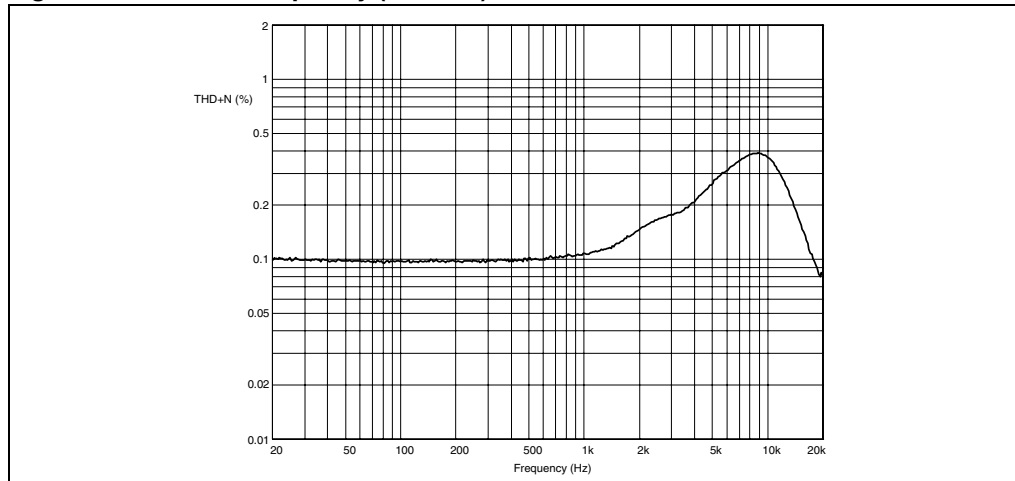

Figure 9. Frequency response

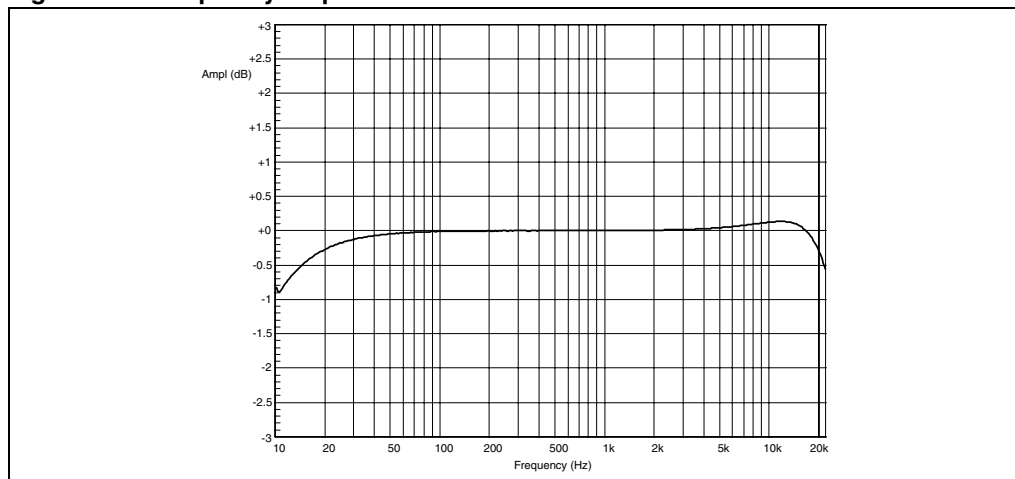

Figure 10. FFT performance (0 dBFS)

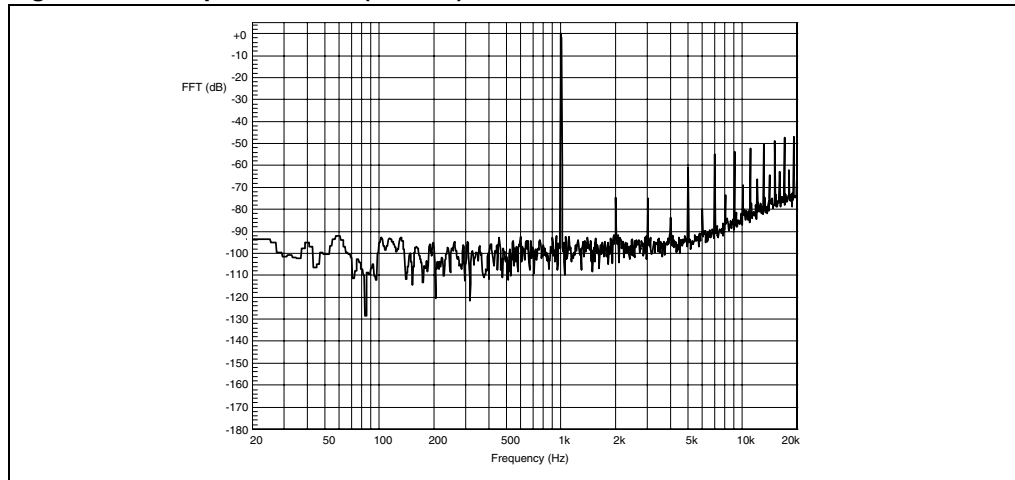
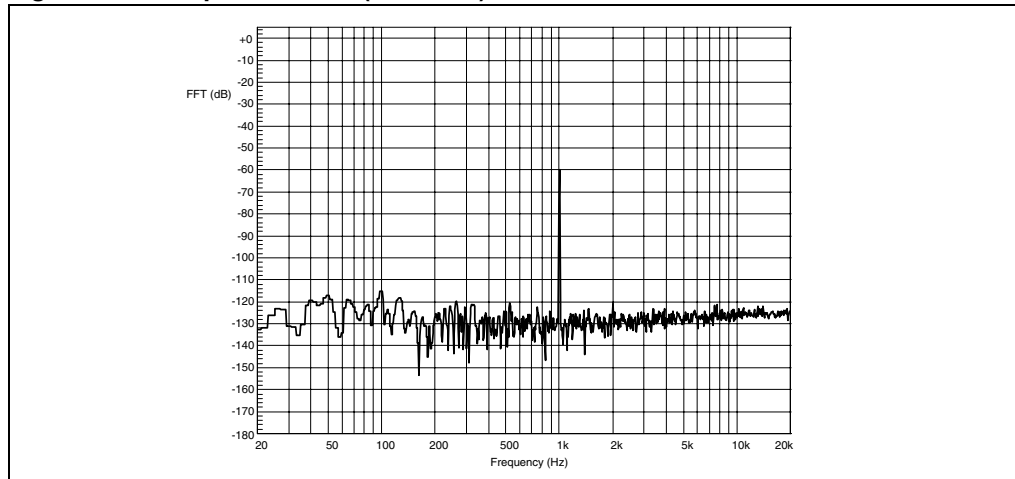

Figure 11. FFT performance (-60 dBFS)



4.2.2 For  $R_L = 8 \Omega$

Figure 12. Output power (THD = 10%) vs. supply voltage

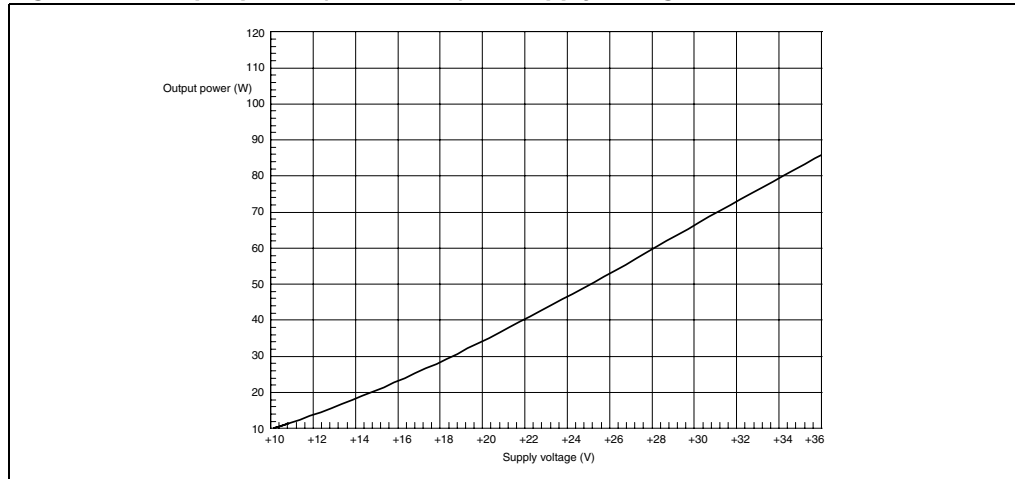

Figure 13. THD vs. output power

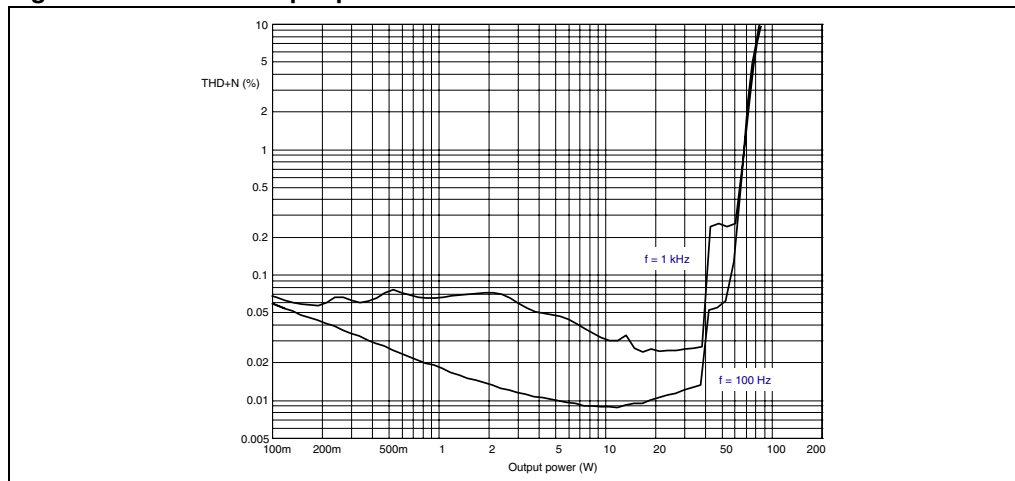



Figure 14. THD vs. frequency (1 W)

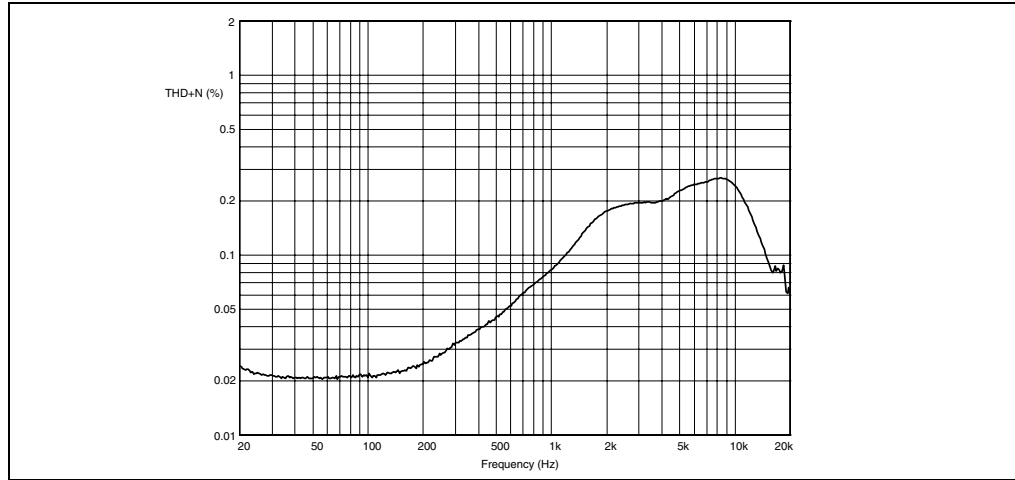

Figure 15. THD vs. frequency (100 mW)

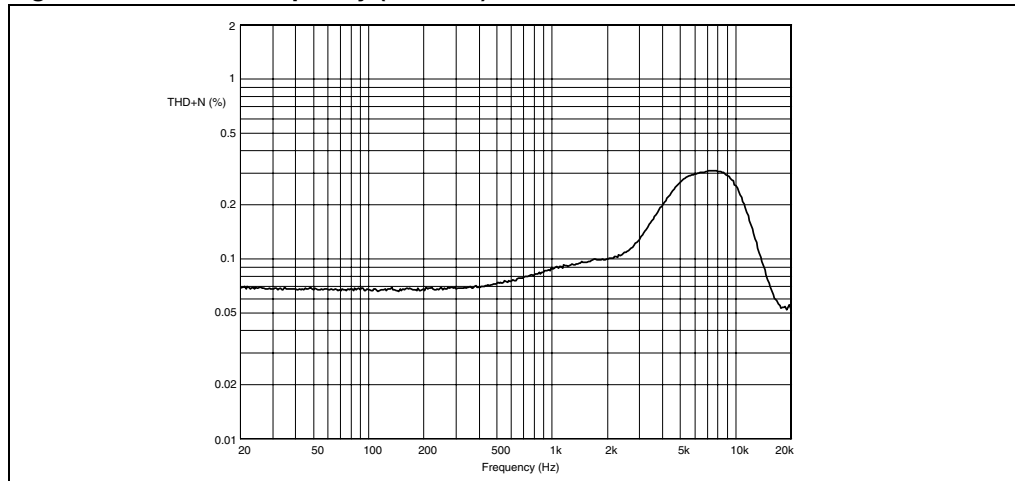

Figure 16. Frequency response

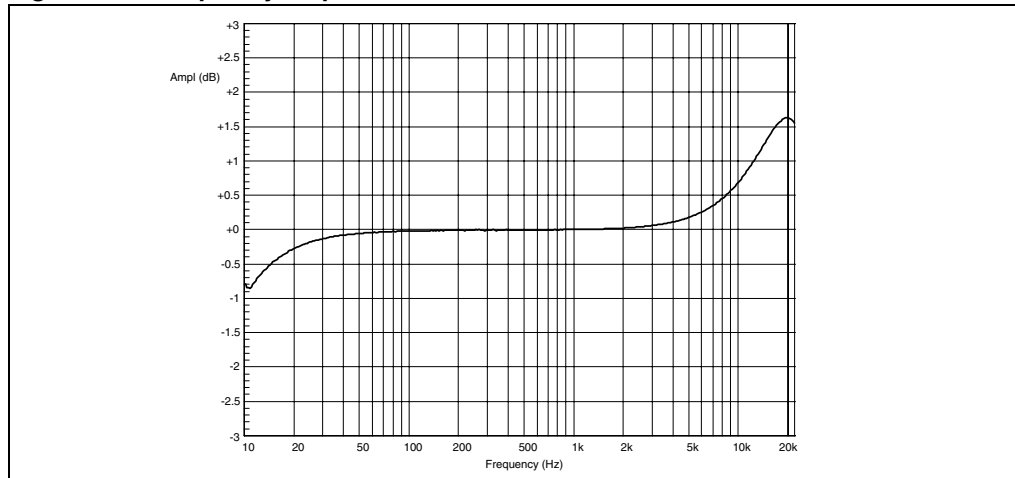

Figure 17. FFT performance (0 dB)

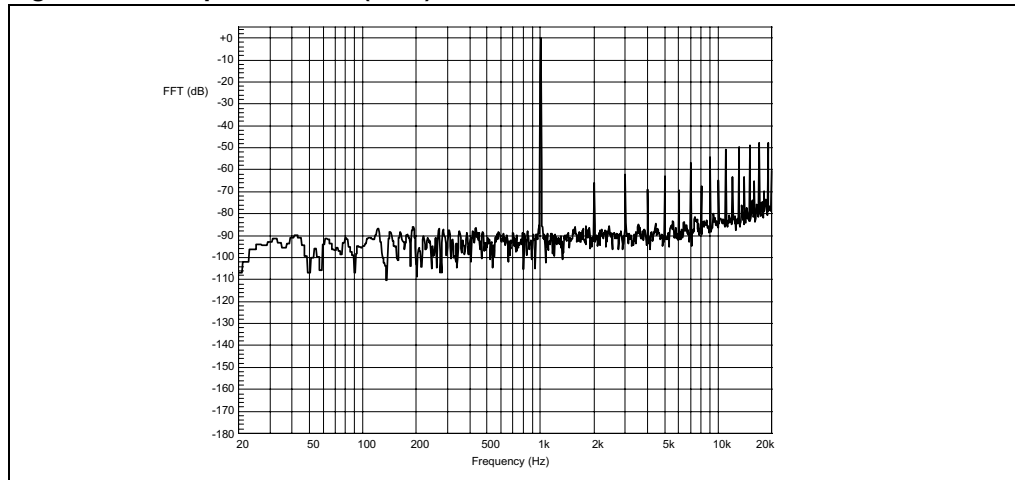
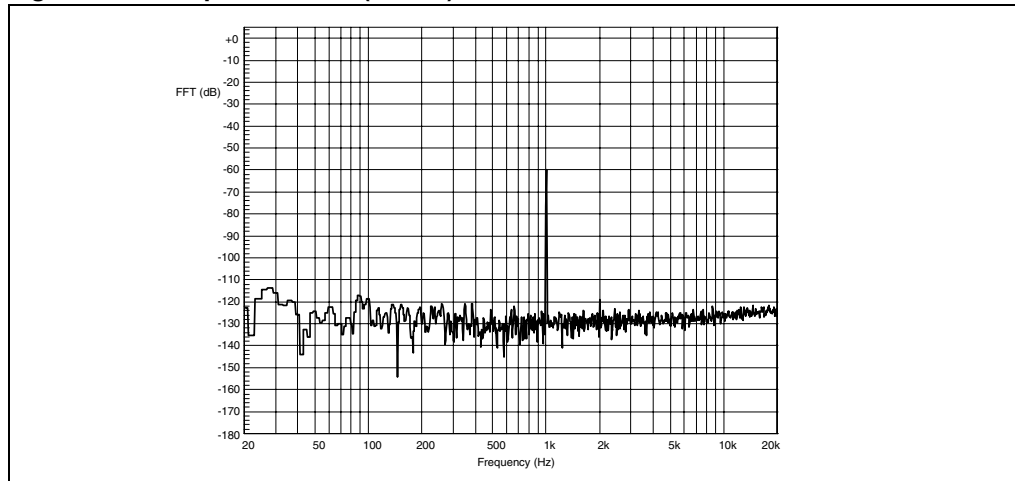

Figure 18. FFT performance (-60 dB)



# 5 Applications information

## 5.1 Applications circuit

Figure 19. Applications circuit for 6-Ω speakers

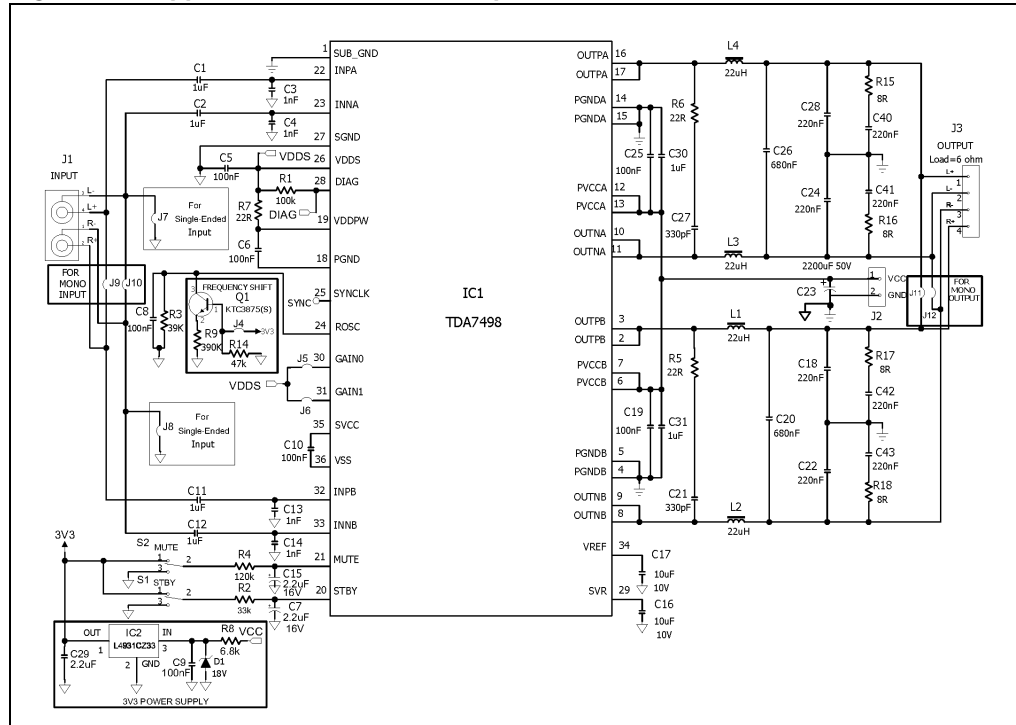
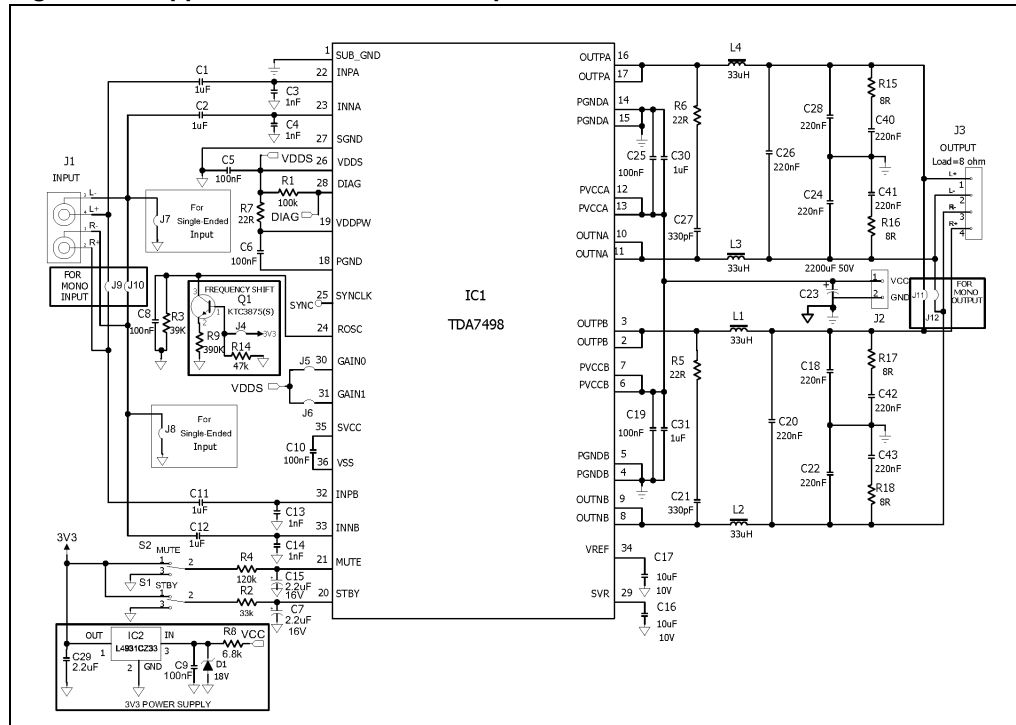

Figure 20. Applications circuit for 8-Ω speakers



## 5.2 Mode selection

The three operating modes of the TDA7498 are set by the two inputs, STBY (pin 20) and MUTE (pin 21).

- Standby mode: all circuits are turned off, very low current consumption.
- Mute mode: inputs are connected to ground and the positive and negative PWM outputs are at 50% duty cycle.
- Play mode: the amplifiers are active.

The protection functions of the TDA7498 are realized by pulling down the voltages of the STBY and MUTE inputs shown in [Figure 21](#). The input current of the corresponding pins must be limited to 200 μA.

Table 7. Mode settings

Mode	STBY	MUTE
Standby	L <sup>(1)</sup>	X (don't care)
Mute	H <sup>(1)</sup>	L
Play	H	H

1. Drive levels defined in [Table 6: Electrical specifications on page 8](#)

Figure 21. Standby and mute circuits

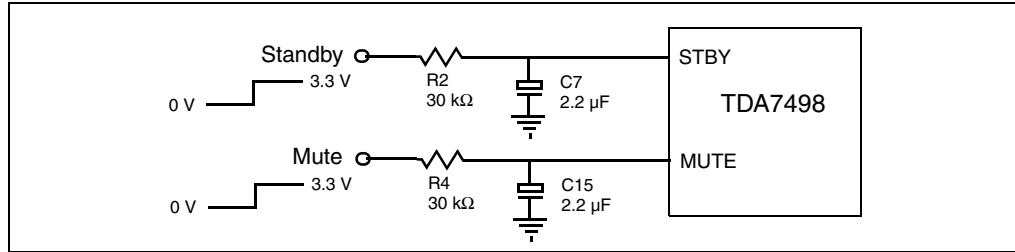
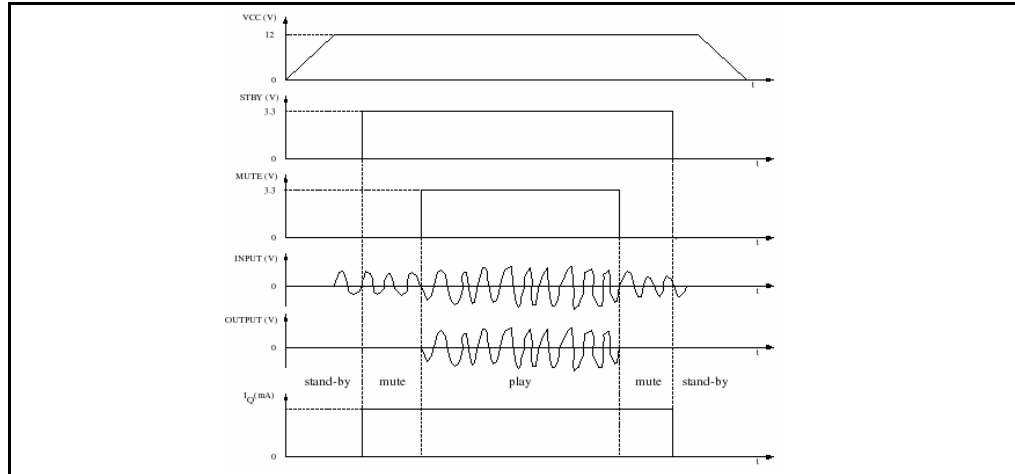

Figure 22. Turn on/off sequence for minimizing speaker “pop”



### 5.3 Gain setting

The gain of the TDA7498 is set by the two inputs, GAIN0 (pin 30) and GAIN1 (pin31). Internally, the gain is set by changing the feedback resistors of the amplifier.

Table 8. Gain settings

GAIN0	GAIN1	Nominal gain, $G_v$ (dB)
L	L	25.6
L	H	31.6
H	L	35.6
H	H	37.6

## 5.4 Input resistance and capacitance

The input impedance is set by an internal resistor  $R_i = 60 \text{ k}\Omega$  (typical). An input capacitor ( $C_i$ ) is required to couple the AC input signal.

The equivalent circuit and frequency response of the input components are shown in [Figure 23](#). For  $C_i = 470 \text{ nF}$  the high-pass filter cut-off frequency is below 20 Hz:

$$f_c = 1 / (2 * \pi * R_i * C_i)$$

**Figure 23. Input circuit and frequency response**

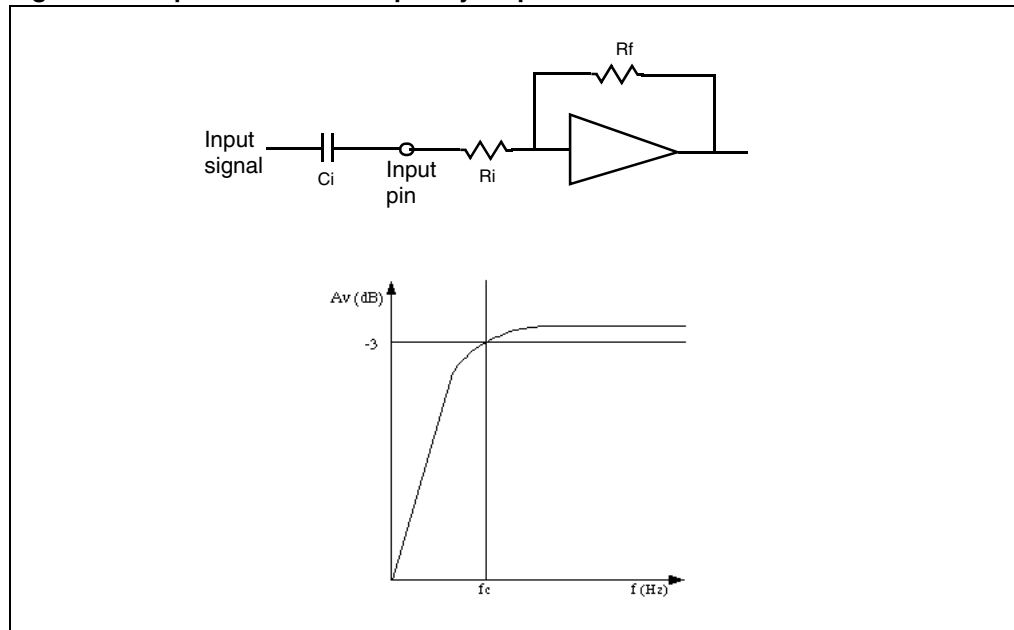

## 5.5 Internal and external clocks

The clock of the class-D amplifier can be generated internally or can be driven by an external source.

If two or more class-D amplifiers are used in the same system, it is recommended that all devices operate at the same clock frequency. This can be implemented by using one TDA7498 as master clock, while the other devices are in slave mode, that is, externally clocked. The clock interconnect is via pin SYNCLK of each device. As explained below, SYNCLK is an output in master mode and an input in slave mode.

### 5.5.1 Master mode (internal clock)

Using the internal oscillator, the output switching frequency,  $f_{SW}$ , is controlled by the resistor,  $R_{OSC}$ , connected to pin ROOSC:

$$f_{SW} = 10^6 / ((R_{OSC} * 16 + 182) * 4) \text{ kHz}$$

where  $R_{OSC}$  is in  $k\Omega$ .

In master mode, pin SYNCLK is used as a clock output pin whose frequency is:

$$f_{SYNCLK} = 2 * f_{SW}$$

For master mode to operate correctly then resistor  $R_{OSC}$  must be less than 60  $k\Omega$  as given below in [Table 9](#).

### 5.5.2 Slave mode (external clock)

In order to accept an external clock input the pin ROOSC must be left open, that is, floating. This forces pin SYNCLK to be internally configured as an input as given in [Table 9](#).

The output switching frequency of the slave devices is:

$$f_{SW} = f_{SYNCLK} / 2$$

**Table 9. How to set up SYNCLK**

Mode	ROOSC	SYNCLK
Master	$R_{OSC} < 60 \text{ k}\Omega$	Output
Slave	Floating (not connected)	Input

**Figure 24. Master and slave connection**

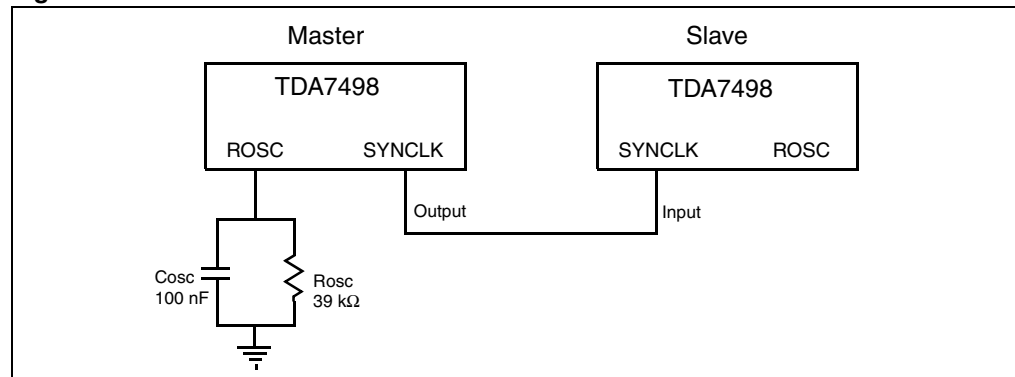

## 5.6 Output low-pass filter

To avoid EMI problems, it may be necessary to use a low-pass filter before the speaker. The cut-off frequency should be larger than 22 kHz and much lower than the output switching frequency. It is necessary to choose the L and C component values depending on the loud-speaker impedance. Some typical values, which give a cut-off frequency of 27 kHz, are shown in [Figure 25](#) and [Figure 26](#) below.

**Figure 25. Typical LC filter for a 8-Ω speaker**

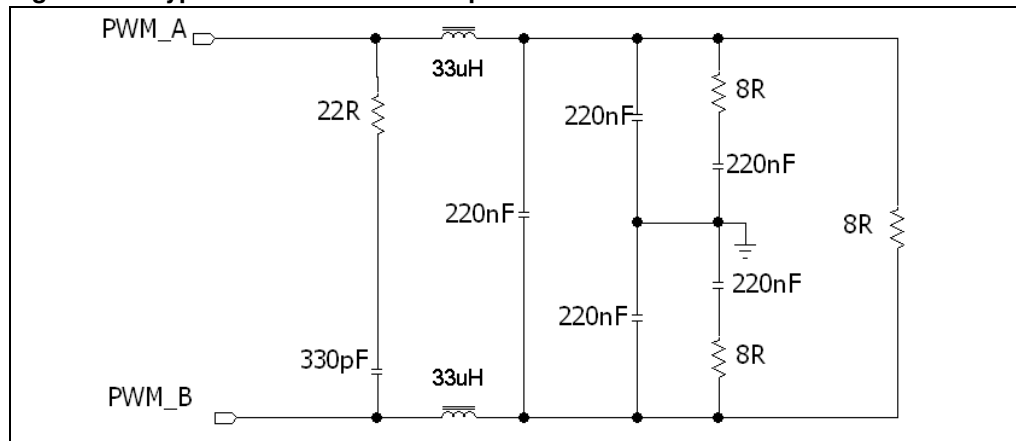

**Figure 26. Typical LC filter for a 6-Ω speaker**

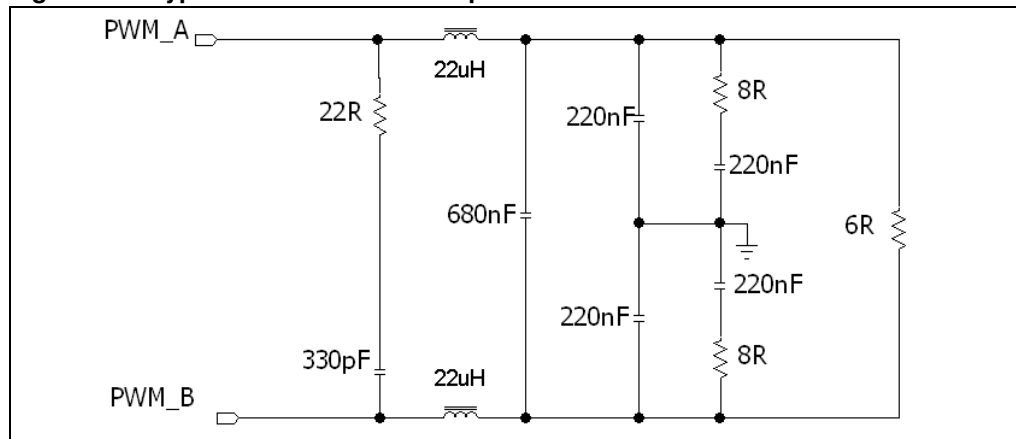



## 5.7 Protection function

The TDA7498 is fully protected against overvoltages, undervoltages, overcurrents and thermal overloads as explained here.

### Overvoltage protection (OVP)

If the supply voltage exceeds the value for  $V_{OVP}$  given in [Table 6: Electrical specifications on page 8](#) the overvoltage protection is activated which forces the outputs to the high-impedance state. When the supply voltage falls back to within the operating range the device restarts.

### Undervoltage protection (UVP)

If the supply voltage drops below the value for  $V_{UVP}$  given in [Table 6: Electrical specifications on page 8](#) the undervoltage protection is activated which forces the outputs to the high-impedance state. When the supply voltage recovers to within the operating range the device restarts.

### Overcurrent protection (OCP)

If the output current exceeds the value for  $I_{OCP}$  given in [Table 6: Electrical specifications on page 8](#) the overcurrent protection is activated which forces the outputs to the high-impedance state. Periodically, the device attempts to restart. If the overcurrent condition is still present then the OCP remains active. The restart time,  $T_{OC}$ , is determined by the R-C components connected to pin STBY.

### Thermal protection (OTP)

If the junction temperature,  $T_j$ , reaches 145 °C (nominally), the device goes to mute mode and the positive and negative PWM outputs are forced to 50% duty cycle. If the junction temperature reaches the value for  $T_j$  given in [Table 6: Electrical specifications on page 8](#) the device shuts down and the output is forced to the high-impedance state. When the device cools sufficiently the device restarts.

## 5.8 Diagnostic output

The output pin DIAG is an open drain transistor. When any protection is activated it switches to the high-impedance state. The pin can be connected to a power supply (< 39 V) by a pull-up resistor whose value is limited by the maximum sinking current (200  $\mu$ A) of the pin.

**Figure 27. Behavior of pin DIAG for various protection conditions**

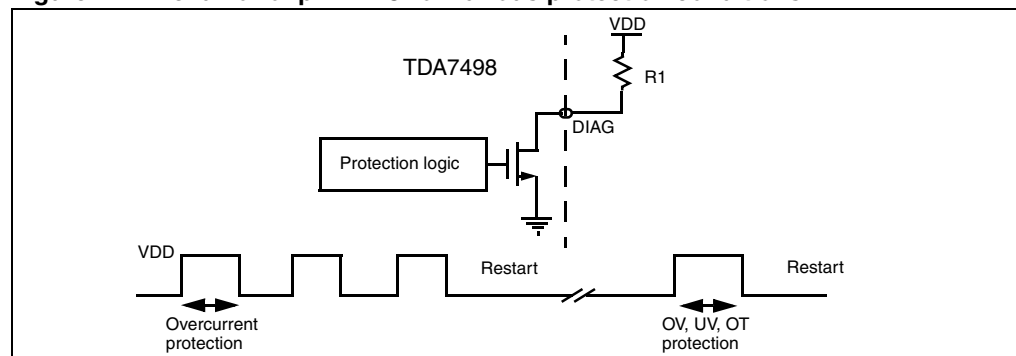

## 6 Package mechanical data

The TDA7498 comes in a 36-pin PowerSSO package with exposed pad up.

[Figure 28](#) shows the package outline and [Table 10](#) gives the dimensions.

**Table 10. PowerSSO36 EPU dimensions**

Symbol	Dimensions in mm			Dimensions in inches		
	Min	Typ	Max	Min	Typ	Max
A	2.15	-	2.45	0.085	-	0.096
A2	2.15	-	2.35	0.085	-	0.093
a1	0	-	0.10	0	-	0.004
b	0.18	-	0.36	0.007	-	0.014
c	0.23	-	0.32	0.009	-	0.013
D	10.10	-	10.50	0.398	-	0.413
E	7.40	-	7.60	0.291	-	0.299
e	-	0.5	-	-	0.020	-
e3	-	8.5	-	-	0.335	-
F	-	2.3	-	-	0.091	-
G	-	-	0.10	-	-	0.004
H	10.10	-	10.50	0.398	-	0.413
h	-	-	0.40	-	-	0.016
k	0	-	8 degrees	-	-	8 degrees
L	0.60	-	1.00	0.024	-	0.039
M	-	4.30	-	-	0.169	-
N	-	-	10 degrees	-	-	10 degrees
O	-	1.20	-	-	0.047	-
Q	-	0.80	-	-	0.031	-
S	-	2.90	-	-	0.114	-
T	-	3.65	-	-	0.144	-
U	-	1.00	-	-	0.039	-
X	4.10	-	4.70	0.161	-	0.185
Y	4.90	-	7.10	0.193	-	0.280

In order to meet environmental requirements, ST offers these devices in different grades of ECOPACK<sup>®</sup> packages, depending on their level of environmental compliance. ECOPACK<sup>®</sup> specifications, grade definitions and product status are available at: [www.st.com](http://www.st.com). ECOPACK<sup>®</sup> is an ST trademark.

Figure 28. PowerSSO36 EPU outline drawing

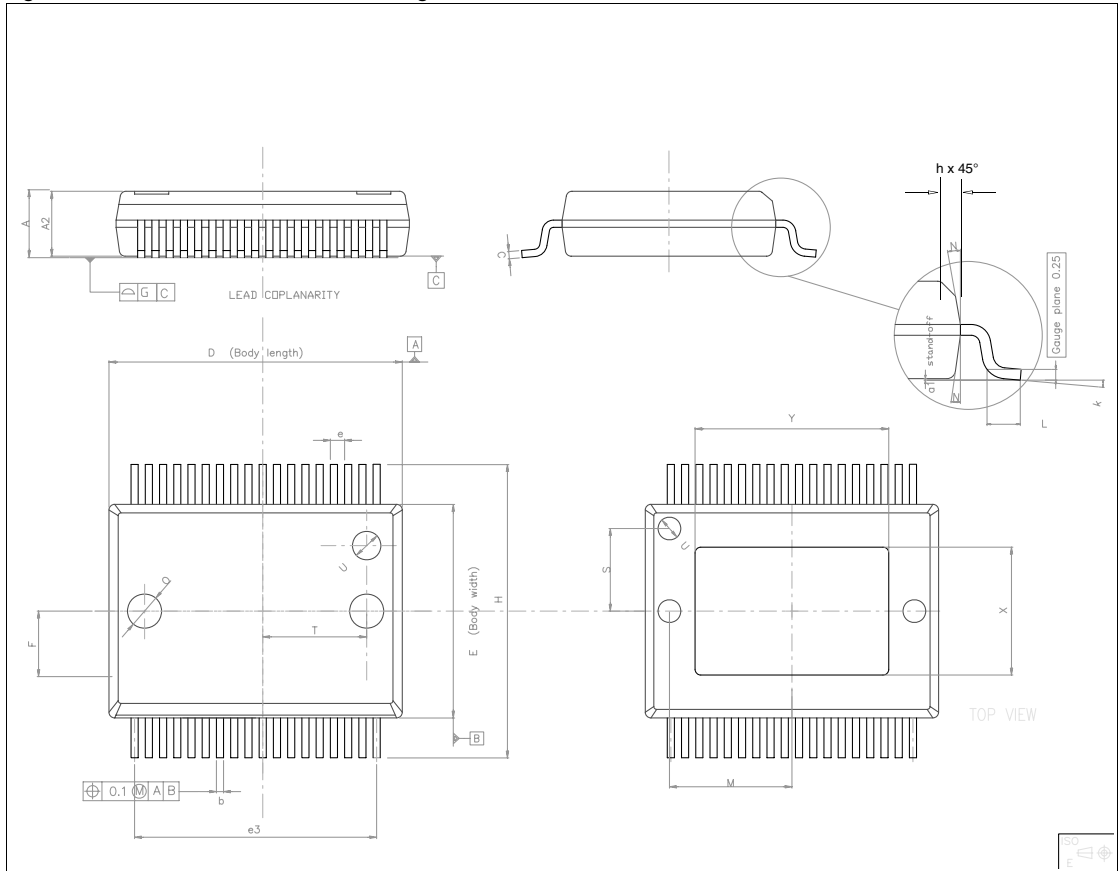

## 7 Revision history

**Table 11. Document revision history**

Date	Revision	Changes
11-Aug-2009	1	Initial release.
27-Aug-2009	2	Updated supply voltage range <i>on page 1</i> Updated package exposed pad dimension Y (Min) in <i>Table 10 on page 26</i> .
23-Oct-2009	3	Updated first feature <i>on page 1</i> Updated order code name in <i>Table 1 on page 1</i> Updated <i>Table 5: Electrical specifications on page 8</i> Updated <i>Section 4.2: Characterization curves on page 13</i> Removed tables for standby, mute and gain after <i>Figure 19 on page 19</i> .
30-Jun-2010	4	Removed datasheet preliminary status, updated features list and updated Device summary table <i>on page 1</i> Added <i>Table 5: Recommended operating conditions on page 8</i> with updated minimum supply voltage

**Please Read Carefully:**

Information in this document is provided solely in connection with ST products. STMicroelectronics NV and its subsidiaries ("ST") reserve the right to make changes, corrections, modifications or improvements, to this document, and the products and services described herein at any time, without notice.

All ST products are sold pursuant to ST's terms and conditions of sale.

Purchasers are solely responsible for the choice, selection and use of the ST products and services described herein, and ST assumes no liability whatsoever relating to the choice, selection or use of the ST products and services described herein.

No license, express or implied, by estoppel or otherwise, to any intellectual property rights is granted under this document. If any part of this document refers to any third party products or services it shall not be deemed a license grant by ST for the use of such third party products or services, or any intellectual property contained therein or considered as a warranty covering the use in any manner whatsoever of such third party products or services or any intellectual property contained therein.

**UNLESS OTHERWISE SET FORTH IN ST'S TERMS AND CONDITIONS OF SALE ST DISCLAIMS ANY EXPRESS OR IMPLIED WARRANTY WITH RESPECT TO THE USE AND/OR SALE OF ST PRODUCTS INCLUDING WITHOUT LIMITATION IMPLIED WARRANTIES OF MERCHANTABILITY, FITNESS FOR A PARTICULAR PURPOSE (AND THEIR EQUIVALENTS UNDER THE LAWS OF ANY JURISDICTION), OR INFRINGEMENT OF ANY PATENT, COPYRIGHT OR OTHER INTELLECTUAL PROPERTY RIGHT.**

**UNLESS EXPRESSLY APPROVED IN WRITING BY AN AUTHORIZED ST REPRESENTATIVE, ST PRODUCTS ARE NOT RECOMMENDED, AUTHORIZED OR WARRANTED FOR USE IN MILITARY, AIR CRAFT, SPACE, LIFE SAVING, OR LIFE SUSTAINING APPLICATIONS, NOR IN PRODUCTS OR SYSTEMS WHERE FAILURE OR MALFUNCTION MAY RESULT IN PERSONAL INJURY, DEATH, OR SEVERE PROPERTY OR ENVIRONMENTAL DAMAGE. ST PRODUCTS WHICH ARE NOT SPECIFIED AS "AUTOMOTIVE GRADE" MAY ONLY BE USED IN AUTOMOTIVE APPLICATIONS AT USER'S OWN RISK.**

Resale of ST products with provisions different from the statements and/or technical features set forth in this document shall immediately void any warranty granted by ST for the ST product or service described herein and shall not create or extend in any manner whatsoever, any liability of ST.

ST and the ST logo are trademarks or registered trademarks of ST in various countries.

Information in this document supersedes and replaces all information previously supplied.

The ST logo is a registered trademark of STMicroelectronics. All other names are the property of their respective owners.

© 2010 STMicroelectronics - All rights reserved

STMicroelectronics group of companies

Australia - Belgium - Brazil - Canada - China - Czech Republic - Finland - France - Germany - Hong Kong - India - Israel - Italy - Japan - Malaysia - Malta - Morocco - Philippines - Singapore - Spain - Sweden - Switzerland - United Kingdom - United States of America

[www.st.com](http://www.st.com)

