

DRAWING MADE IN THIRD ANGLE PROJECTION

THIS DRAWING IS UNPUBLISHED. RELEASED FOR PUBLICATION

© COPYRIGHT 19 BY AMP INCORPORATED, HARRISBURG, PA. ALL INTERNATIONAL RIGHTS RESERVED. AMP PRODUCTS MAY BE COVERED BY U.S. AND FOREIGN PATENTS AND/OR PATENTS PENDING.

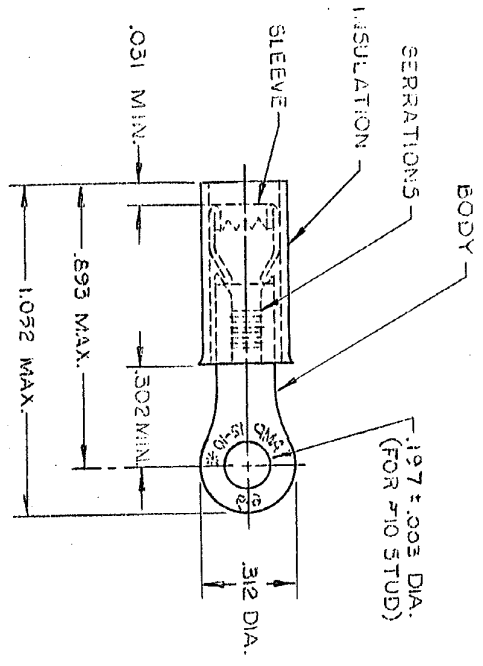

- 1 WIRE INSULATION DIA. = .150 - .230
- 2 TONGUE MATERIAL THK - .040 ± .002
- 3 BODY FINISH = TIN PLATE (MIL-T-10727), .000100 MIN THK.

REVISIONS		DATE	APPROVED
P	ZONE		
F	LTR		
D	REDRAWN - REVISED PER G-1473,	1/3/96	Pjm
E	G-1175 & P85-0133		
F	OBSOLETE 2-1 PER G-2393	3/24/95	mm
G	REV PER G-4732	1/26/94	mm
	REV/0720-0006-93	4-12-93	TD/mk

OBSOLETE

QUANTITY	DESCRIPTION	PART NO
50	LOOSE PC, BOX	8-324918-2
2500	ON TAPE REEL	1-324918-0
4	LOOSE PIECE	324915

UNLESS OTHERWISE SPECIFIED DIMENSIONS ARE IN INCHES TOLERANCES ON: DECIMALS ±.003 ANGLES ±.003	
CONTRACT NO	UT A /RFS 10-3-85
CHK	By [Signature]
APPD	11/21/91 11/21/91 2/3/94
DSGN APPD	
OTHER APPD	
FINISH BODY-	3

NAME	AMP INCORPORATED Harrisburg, Pa.
TERMINAL, RIDG. RING TONGUE WIRE SIZE: 12-10	
SIZE	B
FSGM NO	00779
DRAWING NO	324918
SCALE	NTS
SHEET	1 OF 1

CUSTOMER DRAWING

AMP 1470-17