

- Series 510, 511, & 515 PGA sockets are available in three solder tail lengths: standard, long and low profile.
- Choice of three low force clips to cover all applications.
- Hi-Temp PCT polyester insulator material suitable for all forms of soldering.

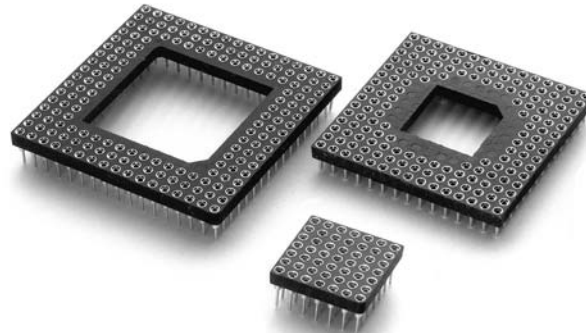

**STANDARD SOLDER TAIL**  
**SERIES 510**

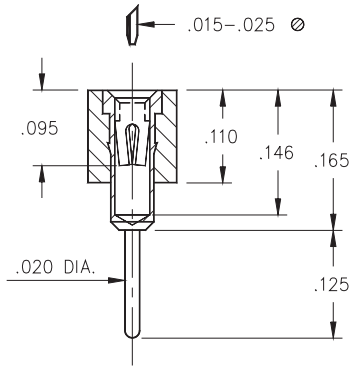

**LONG SOLDER TAIL**  
**SERIES 511**

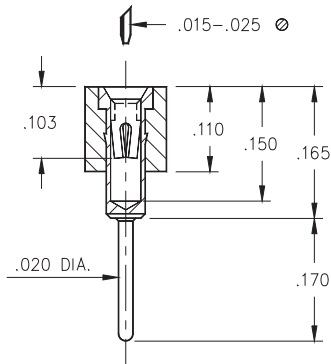

**LOW PROFILE SOLDER TAIL**  
**SERIES 515**

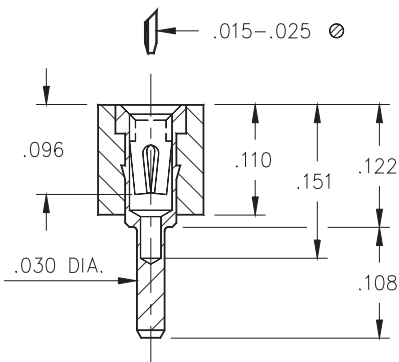

**Ordering Information**

1. Select pin type for PGA socket at left (standard, long, or low profile) to determine series number.
2. Specify 2-digit plating code from chart at bottom of page
3. Locate footprint pattern from pages 107 to 111, the middle 8 digits of the part number will be located under the pattern.
4. Determine the last 2 digits of part number from the Contact Chart below.

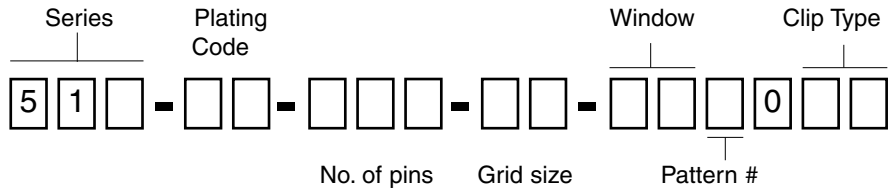

Determined from footprint pattern pages 107 to 111

**EXAMPLE OF COMPLETE PART NUMBER:**

510-93-068-11-061001

This is a 68 pin (11x11 grid) insulator with a .6" square window and fitted with standard solder tail socket pins. Pins are tin plated, inner contacts are Mill-Max #32 and are plated 30μ" gold.

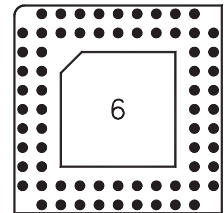

**Clip Type Contact (Clip) Chart**

01	Mill-Max #32 clip, standard low force, recommended for devices with less than 150 pins. See page 208 for details.
02	Mill-Max #35 clip, ultra low force, recommended for devices with more than 150 pins, but less than 250 pins. See page 209 for details.
03	Mill-Max #43 clip, "ultra lite", recommended for devices with more than 250 pins. See page 209 for details.

SPECIFY PLATING CODE XX=	13	91	93	99
Sleeve (Pin)	10μ" Au	200μ" Sn/Pb	200μ" Sn/Pb	200μ" Sn/Pb
Contact (Clip)	30μ" Au	10μ" Au	30μ" Au	200μ" Sn/Pb