

PRODUCT NO.	END CAP	INSULATOR	RECESS	REMARK
10030574-2100LF/2100RLF	10030578-210	NO	NO/YES	
10030574-2101LF/2101RLF	10030578-210	YES	NO/YES	
10030574-0000LF/0000RLF	NO	NO	NO/YES	SEE NOTE 5
10030574-0001LF/0001RLF	NO	YES	NO/YES	SEE NOTE 5
10030574-0010LF/0010RLF	NO	NO	NO/YES	
10030574-0011LF/0011RLF	NO	YES	NO/YES	
10030574-3100LF/3100RLF	10030578-310	NO	NO/YES	
10030574-3101LF/3101RLF	10030578-310	YES	NO/YES	
10030574-1100LF/1100RLF	10030578-110	NO	NO/YES	
10030574-1101LF/1101RLF	10030578-110	YES	NO/YES	

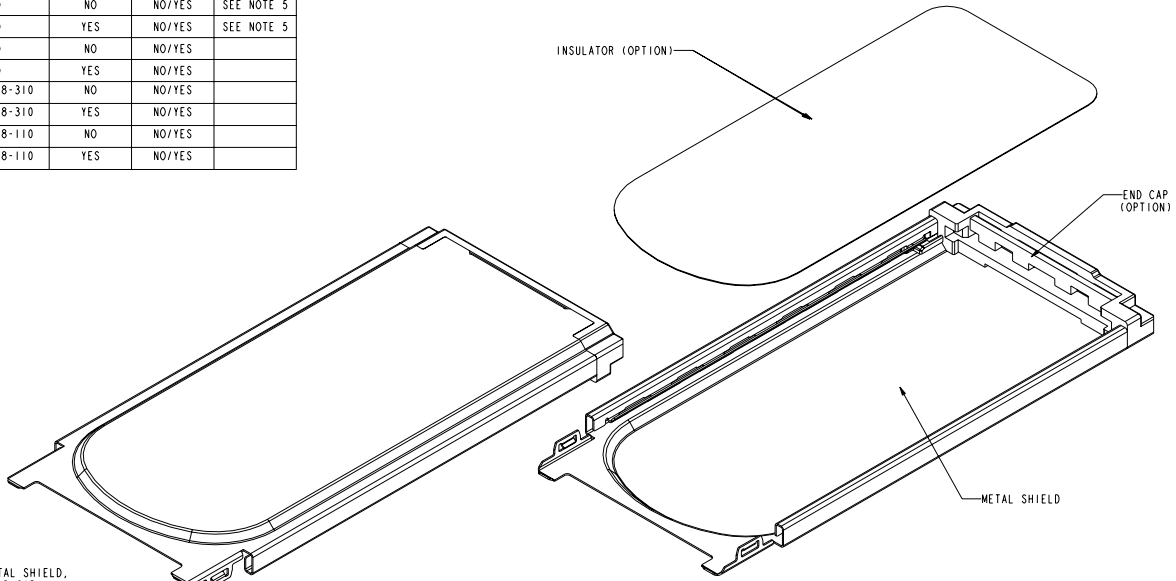

- NOTES:
 1. THIS PRODUCT CONTAINS ONE METAL SHIELD, INSULATOR AND ONE PLASTIC END CAP;
 2. PRODUCT PERFORMANCE REFER TO GS-12-292;
 3. PART NUMBER SCHEME:

10030574- X X X X R L F

- WITH RECESS FEATURE
- INSULATOR: 0: NO, 1: YES
- 0: STANDARD SHIELD
- 1: EXTENDED SHIELD
- PLASTIC COLOR
- 0: W/O END CAP
- 1: BLACK
- OFFSET (END CAP)
- 0: W/O END CAP
- 1: +0.00
- 2: +0.30
- 3: +0.60

4. PACKAGING SPECIFICATION REFER TO GS-14-927;
 5. THE P/N IS TEMPORARY FOR CUSTOMER SPECIAL REQUEST, MATING WITH END CAP IS THE RECOMMENDED PARTS;
 6. THIS PRODUCT IS ROHS COMPLIANT, AND MEETS EUROPEAN UNION DIRECTIVES AND OTHER COUNTRY REGULATIONS AS PER GS-22-008;
 7. DATE CODE FORMATE: WWYY (WEEK YEAR), FOR EXAMPLE, 2207 MEANS WEEK 22 AND YEAR 2007.

rev	ecn no	dr	date
H	N07-0201	MSH	2007-08-28
J	N08-0247	R.B	2008/11/12
-	-	-	-
-	-	-	-

www.fciconnect.com		surface	tolerance std	projection	MM
		ANGULAR	0.x ±0.30	⊕	Scale 1.000
		LINEAR	0.xx ±0.15	⊖	ECN N08-0247
		0° ±2°	0.xxx ±0.08		Product family
					Spec ref
Dr	DAVID TENG	2004-10-04			
Eng	DAVID TENG	2004-10-04			
Chr	PAUL WANG	2004-10-04			
Appr	JOSEPH HSIA	2004-10-04			
FCJ		BOTTOM SHIELD SUB-ASSEMBLY		part no	10030574
		EXPRESSCARD/34 MODULE CARD KIT		Rev.	J
catalog no		10030574	CUSTOMER	sheet 1 of 4	



Copyright FCJ.

REV F - 2004-04-07

PRODUCT NO.
10030574-210XLF

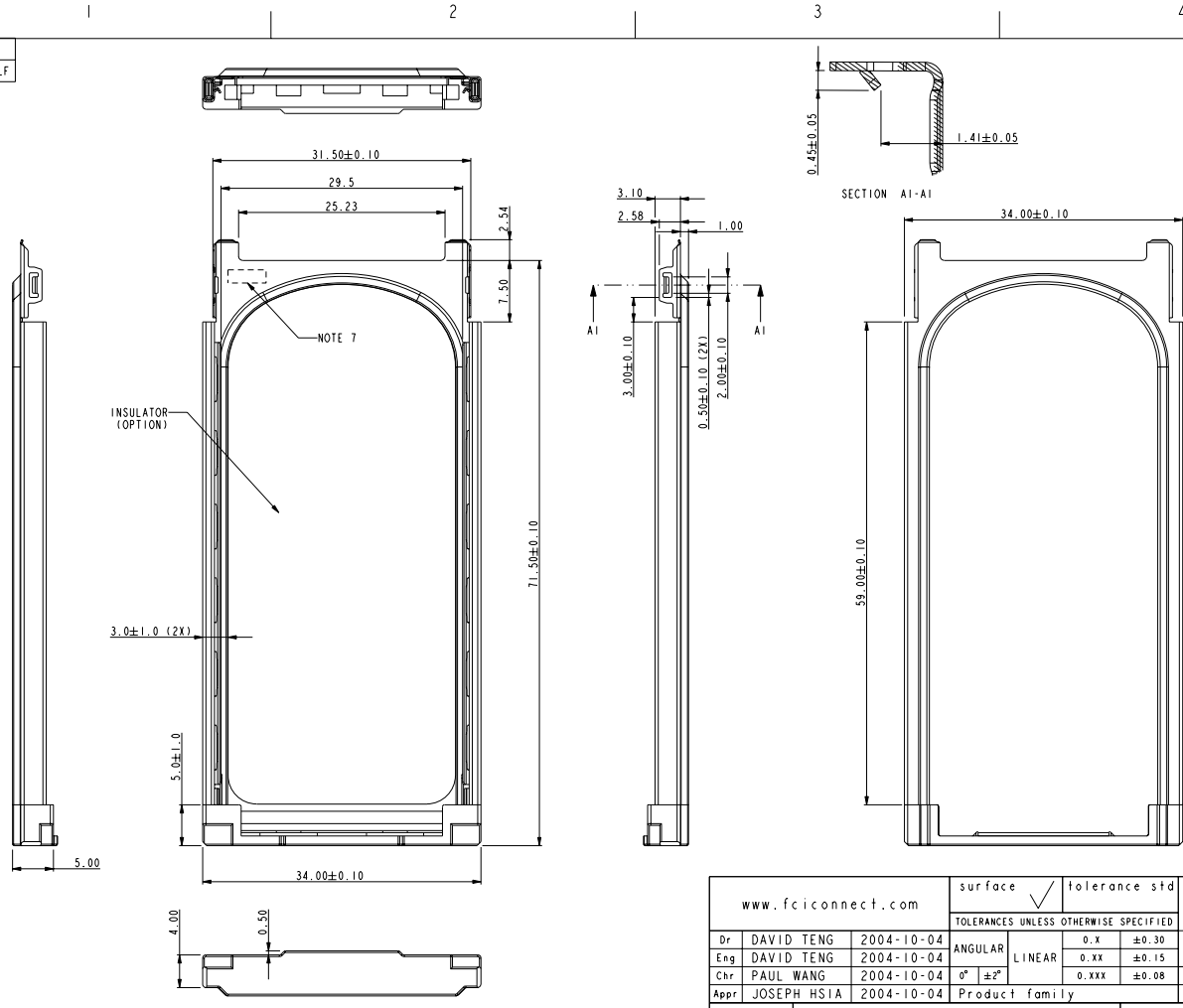

SCALE 1.500

www.fciconnect.com		surface <input checked="" type="checkbox"/>	tolerance std	projection	MM
TOLERANCES UNLESS OTHERWISE SPECIFIED					
Dr	DAVID TENG	2004-10-04	ANGULAR	0.x ±0.30	size A4 Scale 1.000
Eng	DAVID TENG	2004-10-04	LINEAR	0.xx ±0.15	
Chr	PAUL WANG	2004-10-04	0° ±2°	0.xxx ±0.08	ECN N08-0247
Appr	JOSEPH HSIA	2004-10-04	Product family	Spec ref	
FCI		TITLE BOTTOM SHIELD SUB-ASSEMBLY		Rev. J	
EXPRESSCARD/34 MODULE CARD KIT		dwg no 10030574		CUSTOMER	
catalog no 10030574		CUSTOMER		sheet 2 of 4	

3 PDM: Rev:J STATUS Released 4 Printed: Oct 12, 2010

Copyright FCI.



Copyright FCI.

PRODUCT NO.
10030574-000XLF
10030574-001XLF

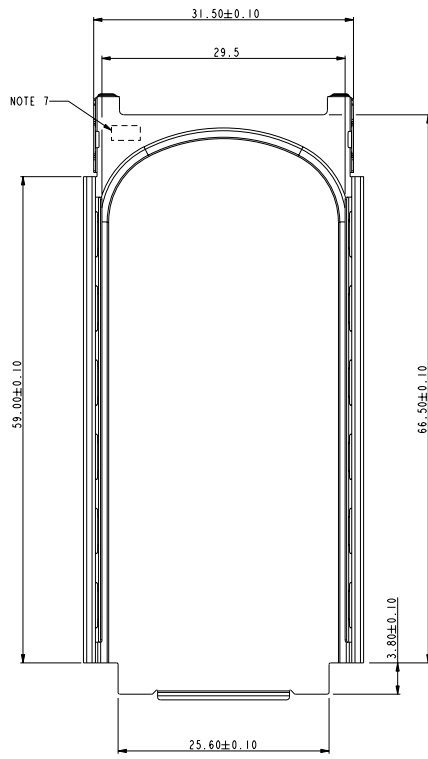

10030574-000XLF

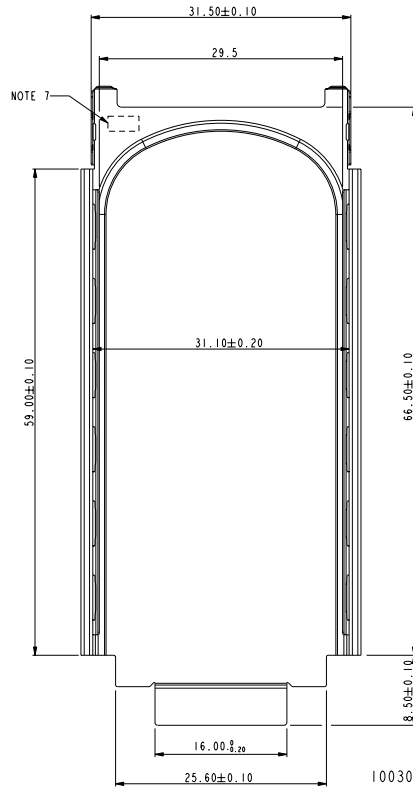

10030574-001XLF

www.fciconnect.com		surface <input checked="" type="checkbox"/>	tolerance std	projection	MM	
TOLERANCES UNLESS OTHERWISE SPECIFIED						
Dr	DAVID TENG	2004-10-04	ANGULAR	0.x	±0.30	size A4
Eng	DAVID TENG	2004-10-04	LINEAR	0.xx	±0.15	Scale 1:000
Chr	PAUL WANG	2004-10-04	0° ±2°	0.xxx	±0.08	ECN N08-0247
Appr	JOSEPH HSIA	2004-10-04	Product family	Spec ref		
FCI		TITLE		Dwg no		Rev.
		BOTTOM SHIELD SUB-ASSEMBLY		10030574		J
		EXPRESSCARD/34 MODULE CARD KIT		CUSTOMER		sheet 3 of 4
		catalog no 10030574				

REV F - 2004-04-07

3 PDM: Rev:J

STATUS Released

4 Printed: Oct 12, 2010

PART NUMBER
10030574-000XRLF
10030574-001XRLF

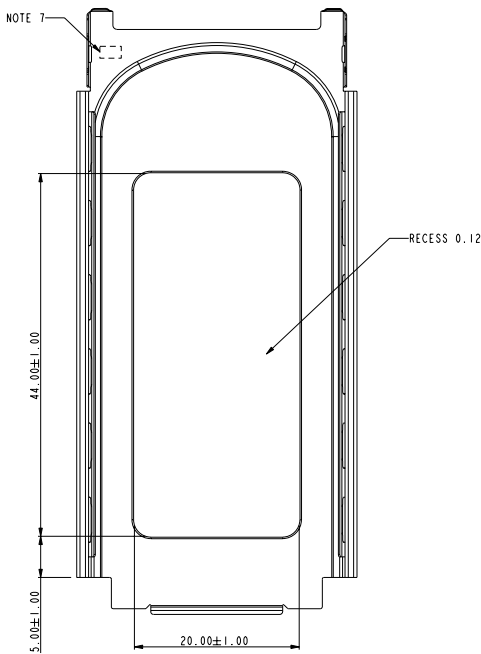

10030574-000XRLF
ALL FEATURE DIMENSIONS ARE SAME AS 10030574-000XLF
EXCEPT THE RECESS FEATURE

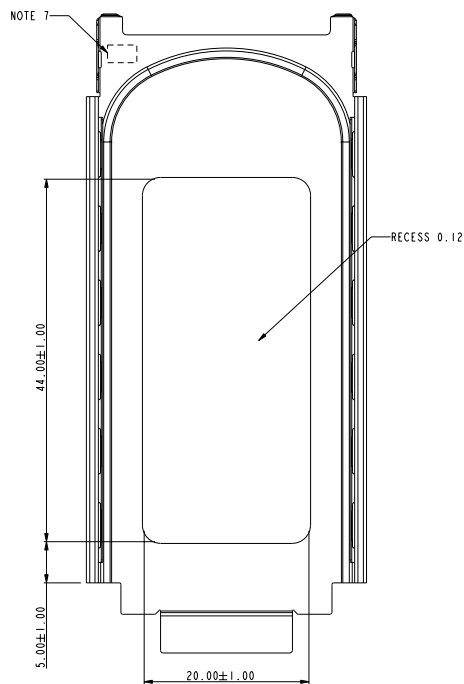

10030574-001XRLF
ALL FEATURE DIMENSIONS ARE SAME AS 10030574-001XLF
EXCEPT THE RECESS FEATURE

www.fciconnect.com		surface <input checked="" type="checkbox"/>	tolerance std	projection	MM
TOLERANCES UNLESS OTHERWISE SPECIFIED					
Dr	DAVID TENG	2004-10-04	ANGULAR	0.x ±0.30	size A4 Scale 1.000
Eng	DAVID TENG	2004-10-04	LINEAR	0.xx ±0.15	
Chr	PAUL WANG	2004-10-04	0° ±2°	0.xxx ±0.08	ECN N08-0247
Appr	JOSEPH HSIA	2004-10-04	Product family	Spec ref	
FCJ		TITLE BOTTOM SHIELD SUB-ASSEMBLY		dwg no	10030574
		EXPRESSCARD/34 MODULE CARD KIT		Rev.	J
		catalog no	10030574	CUSTOMER	sheet 4 of 4

3 PDM: Rev:J

STATUS Released

4 Printed: Oct 12, 2010



Copyright FCI.

REV F - 2004-04-07