

PRODUCT NO.	FRONT CAP	END CAP	INSULATOR	REMARK
10030582-2100LF	10030583-210	10030592-210	NO	
10030582-2101LF	10030583-210	10030592-210	YES	
10030582-0000LF	10030583-210	NO	NO	SEE NOTE 5
10030582-0001LF	10030583-210	NO	YES	SEE NOTE 5
10030582-0010LF	10030583-210	NO	NO	
10030582-0011LF	10030583-210	NO	YES (STANDARD)	
10030582-0012LF	10030583-210	NO	YES (SPECIAL)	
10030582-0020LF	10030583-210	NO	NO	
10030582-0021LF	10030583-210	NO	YES	

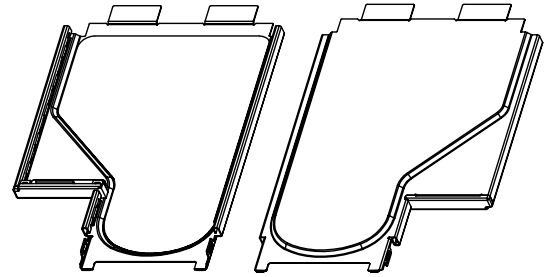

10030582-001XLF

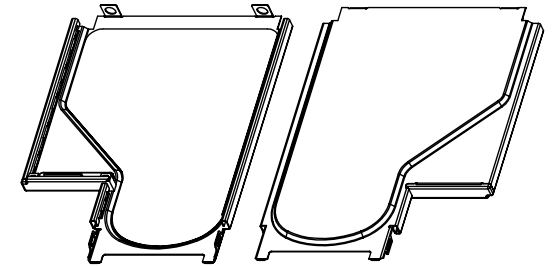

10030582-002XLF

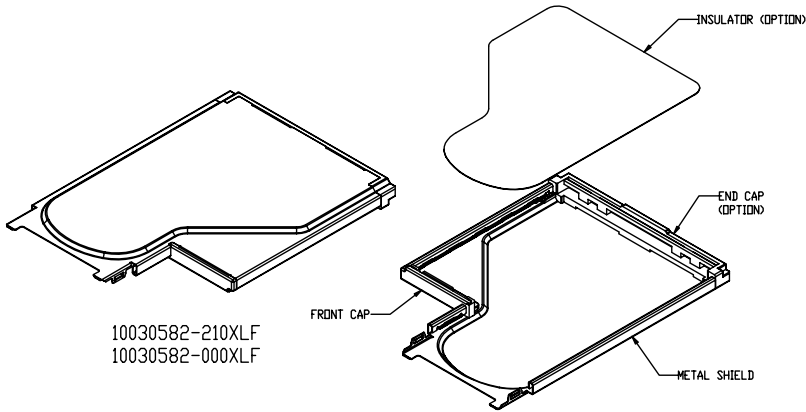

10030582-210XLF
10030582-000XLF

- NOTES:
 1. THIS PRODUCT CONTAINS ONE METAL SHIELD, PLASTIC FRONT CAP INSULATOR AND ONE PLASTIC END CAP.
 2. PRODUCT PERFORMANCE PER SPEC. GS-12-292.
 3. PART NUMBER SCHEME:
 10030582- X X X X L F

- INSULATOR:
 0:ND
 1:STANDARD
 2:SPECIAL
- 0 : STANDARD SHIELD
 1 : EXTENDED SHIELD
 2 : CUSTOMIZED
- PLASTIC COLOR:
 0 : W/D END CAP
 1 : BLACK
- OFFSET (END CAP)
 0 : W/D END CAP
 1 : +0.00 (NOT TOOLDED)
 2 : +0.30
 3 : +0.60 (NOT TOOLDED)

4. PACKAGING SPEC. PER GS-14-927.
 5. THE P/N IS TEMPORARY FOR CUSTOMER SPECIAL REQUEST. STANDARD SHIELD MATING WITH END CAP IS THE RECOMMENDED PARTS.
 6. THIS PRODUCT IS ROHS COMPLIANT, AND MEETS EUROPEAN UNION DIRECTIVES AND OTHER COUNTRY REGULATIONS AS PER GS-22-008.

rev	ecn no	dr	date
A	T04-0382	D T	2004-11-04
B	T05-0083	D T	2005-04-18
C	T05-0152	D T	2005-07-11
D	T05-0228	D T	2005-10-18
E	T06-0015	D T	2006-01-16
F	T06-0057	D T	2006-04-17
G	N07-0094	HB	2007-04-10

www.fciconnect.com		surface	tolerance std	projection	MM
Dr DAVID TENG 2004-10-04		ANGULAR	TOLERANCES UNLESS OTHERWISE SPECIFIED	size A4	Scale 1.000
Eng DAVID TENG 2004-10-04		LINEAR	0.X ±0.30 0.XX ±0.15 0.XXX ±0.08	ECN	
Chr PAUL WANG 2004-10-04		0° ±2°	Product family	Spec ref	
Appr JOSEPH HSIA 2004-10-04					
FCI title BOTTOM SHIELD SUB-ASSEMBLY EXPRESSCARD/54 MODULE CARD KIT		10030582		Rev. J	
catalog no		10030582		CUSTOMER sheet 1 of 5	

3 PDM: Rev:J STATUS Released 4 Printed: Oct 12, 2010



Copyright FCI.

PRODUCT NO.
10030582-210XLF

A

B

C

D

1

2

3

4

A

B

C

D



Copyright FCI.

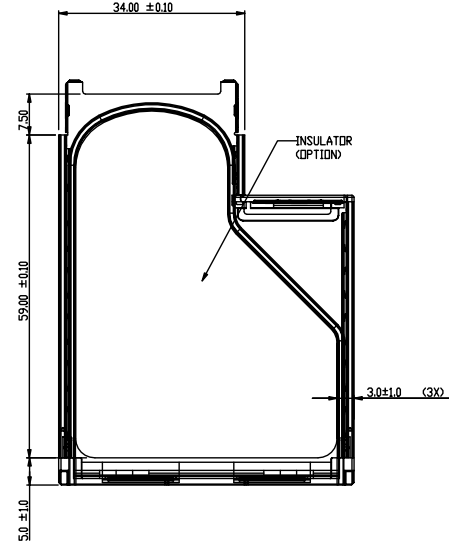
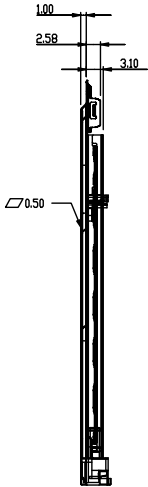
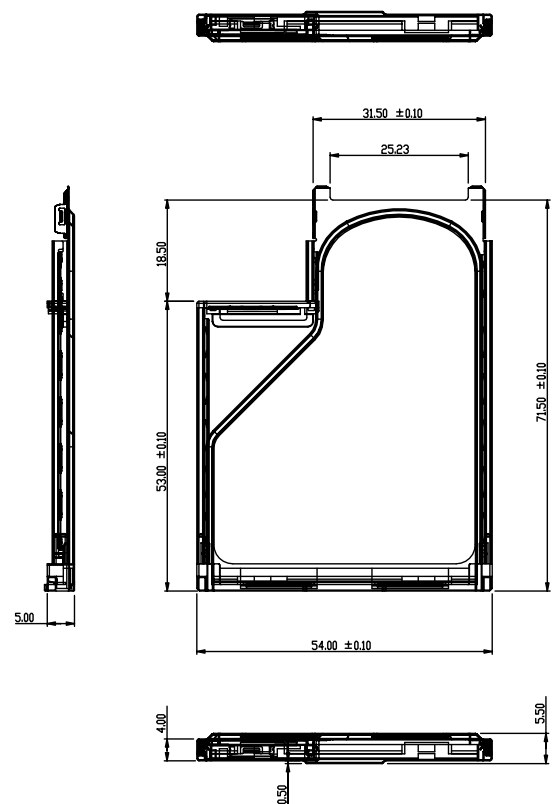

TOLERANCES UNLESS OTHERWISE SPECIFIED		
LINEAR	0.X	±0.30
	0.XX	±0.15
ANGULAR	0.XXX	±0.08
	0°	±2°

	title	BOTTOM SHIELD SUB-ASSEMBLY	drawing no 10030582	customer CUSTOMER	Rev. J
	EXPRESSCARD/54 MODULE CARD KIT catalog no 10030582	sheet 2 of 5			

3 PDM: Rev:J STATUS Released 4 Printed: Oct 12, 2010



Copyright FCJ.

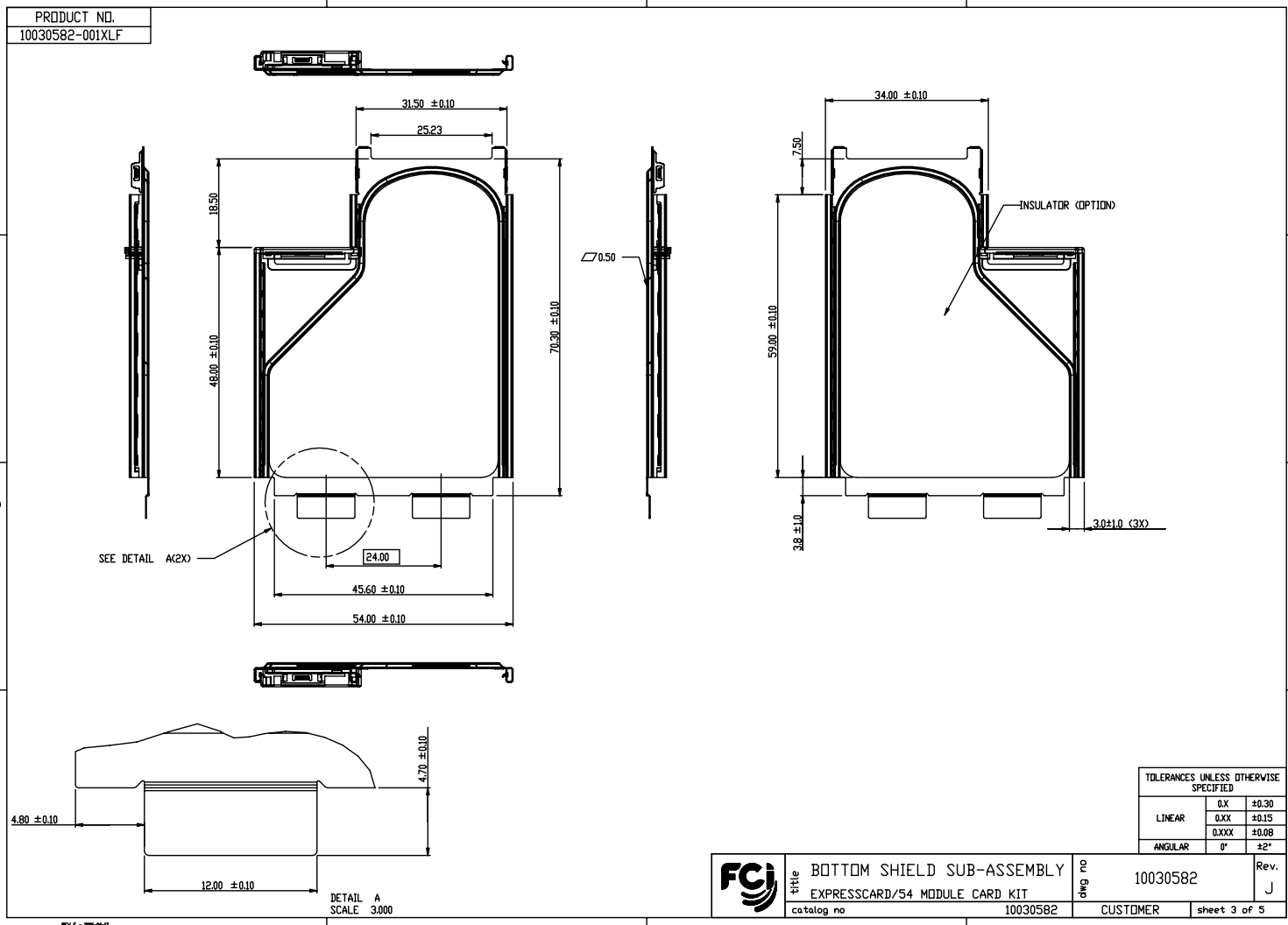

TOLERANCES UNLESS OTHERWISE SPECIFIED		
LINEAR	0.X	±0.30
	0.XX	±0.15
	0.XXX	±0.08
ANGULAR	0°	±2°

	title	BOTTOM SHIELD SUB-ASSEMBLY	part no	10030582	Rev. J
	EXPRESSCARD/54 MODULE CARD KIT				
	catalog no	10030582	CUSTOMER	sheet 3 of 5	

3 PDM: Rev:J STATUS Released 4 Printed: Oct 12, 2010



Copyright FCJ

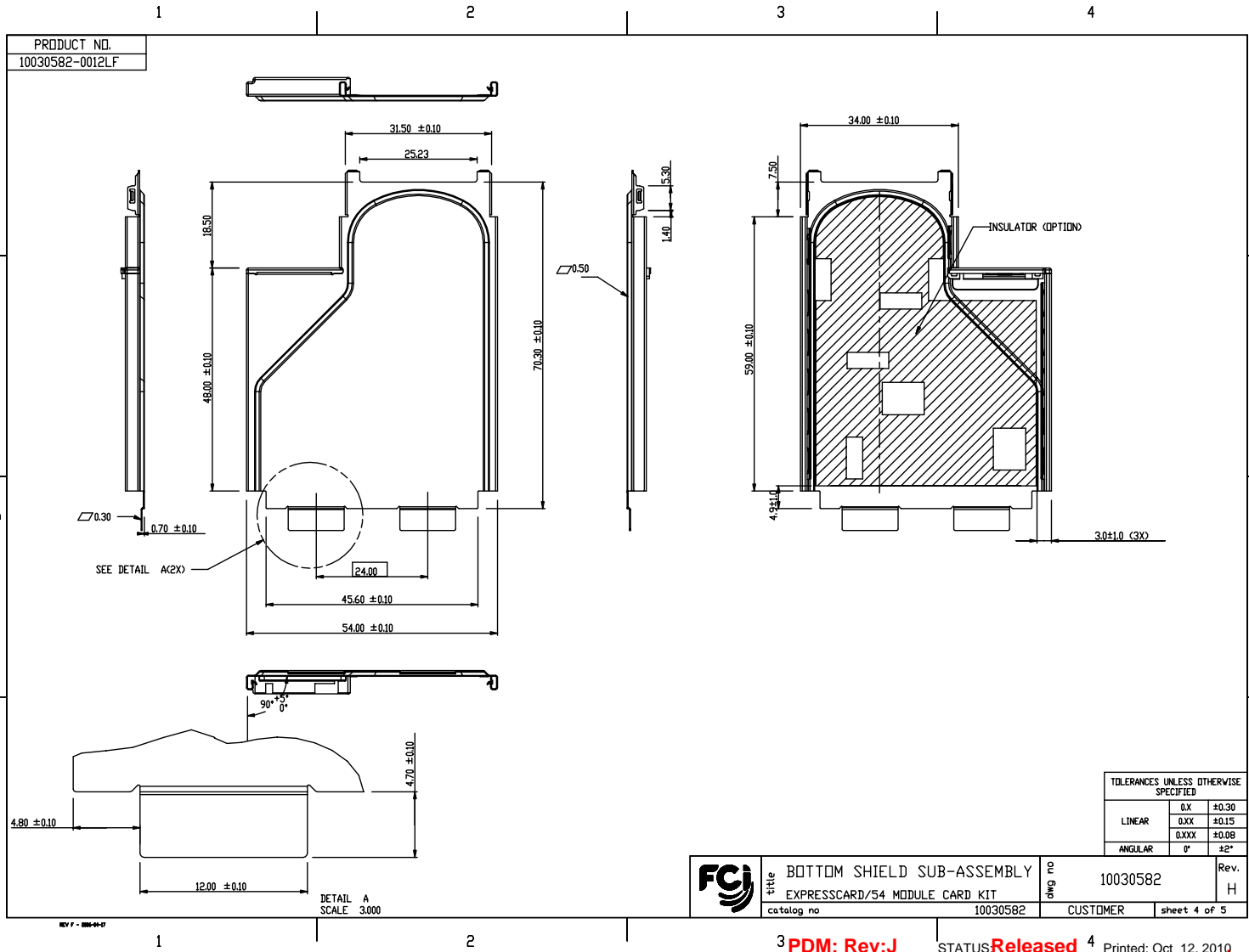

TOLERANCES UNLESS OTHERWISE SPECIFIED		
LINEAR	0.X	±0.30
	0.XX	±0.15
	0.XXX	±0.08
ANGULAR	0°	±2°

	title	BOTTOM SHIELD SUB-ASSEMBLY	part no	10030582	Rev.	H
	EXPRESSCARD/54 MODULE CARD KIT					
	catalog no	10030582	CUSTOMER	sheet 4 of 5		

3 PDM: Rev:J STATUS Released 4 Printed: Oct 12, 2010

PRODUCT NO.
10030582-002XLF

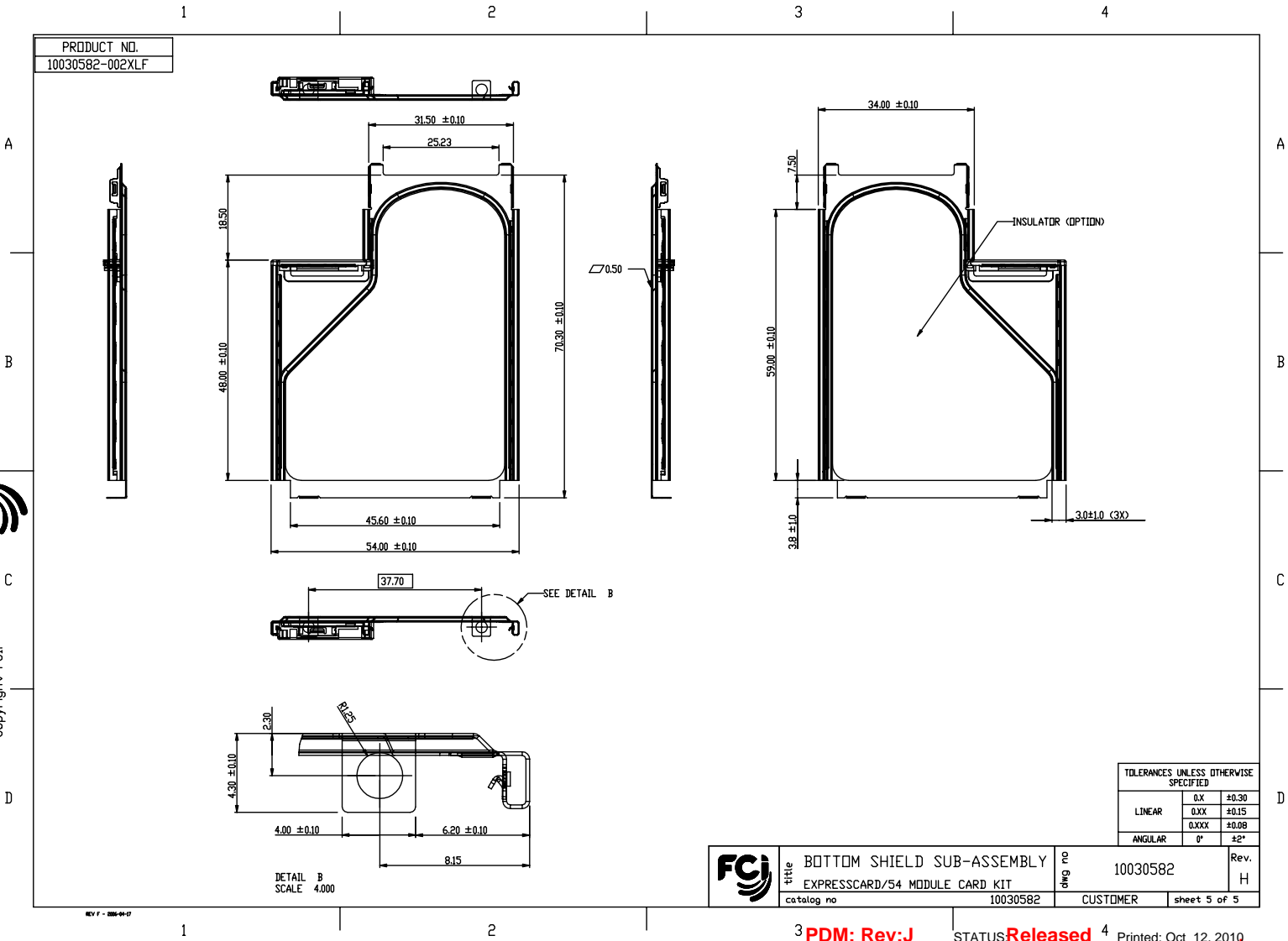

Copyright FCJ.



title	BOTTOM SHIELD SUB-ASSEMBLY	part no	10030582	Rev.	H
	EXPRESSCARD/54 MODULE CARD KIT				
catalog no	10030582	CUSTOMER	sheet 5 of 5		

3 PDM: Rev:J STATUS Released 4 Printed: Oct 12, 2010