



APPLIED SECURITY DESIGN LTD.

## GUARDLITE 9 PHILIPS PL\* LAMP LUMINAIRE WITH PHOTOCELL FOR AUTOMATIC SWITCHING

Applied Security Design Limited's latest introduction in its range of security amenity bulkhead luminaires.

The Guardlite 9 is the first luminaire of its kind specifically designed to accommodate a photocell for automatic switching and a Philips energy saving PL9 lamp which is supplied.

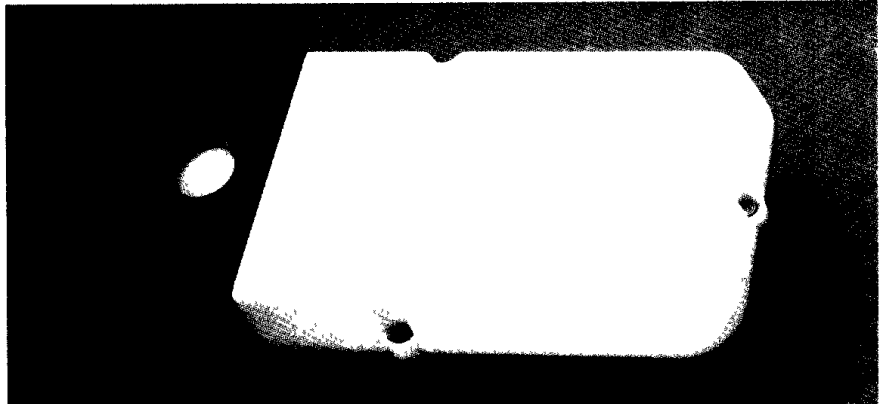

### BENEFITS

- Philips PL9 – 9W only lamp
- Similar light output to 60W G L S lamp
- Lamp life – 5000 hrs  
Thus saving on maintenance and replacement lamps
- Running costs less than £3 per year compared to 60W GLS lamps which cost £14 per year
- Automatic photocell switching reduces installation and operating costs
- Luminaire switches on at dusk and off at dawn
- Universal mounting
- Vandal resistant polycarbonate enclosure
- Anti vandal fixing screws

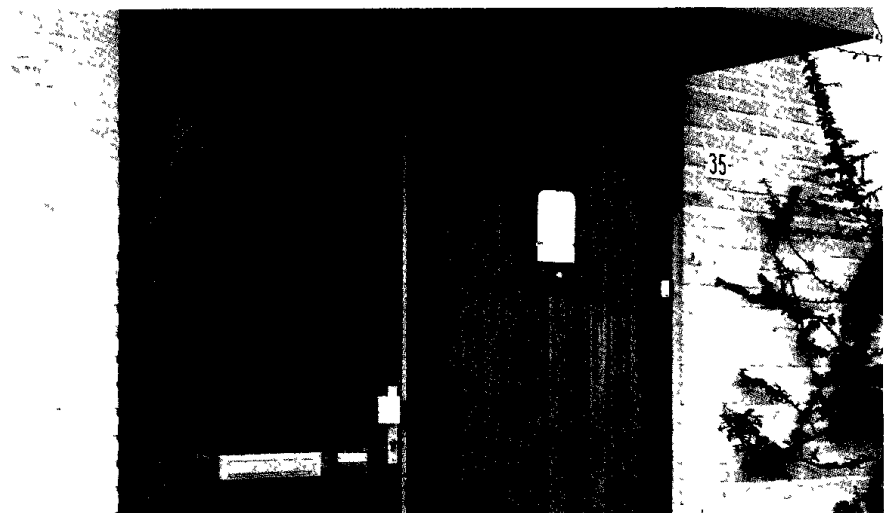
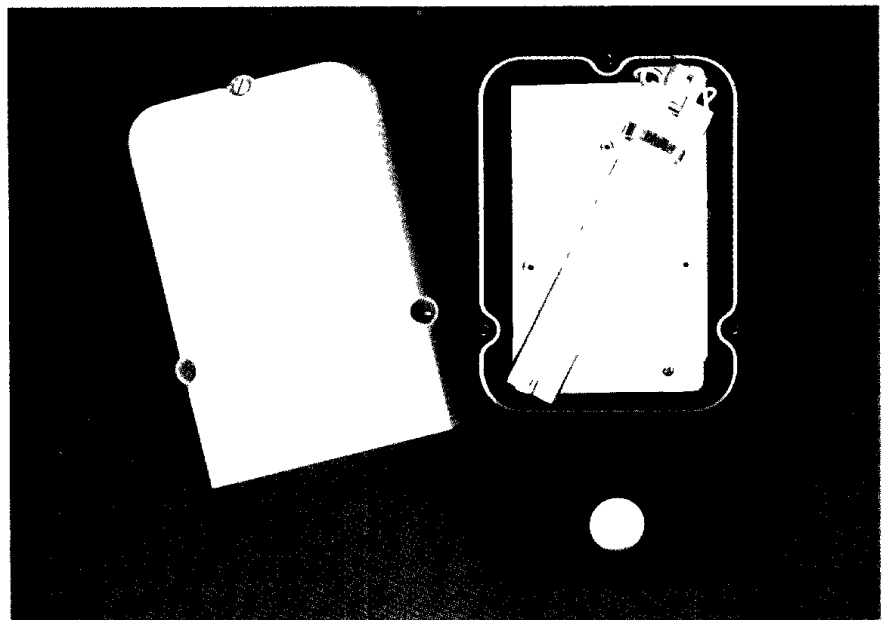

# PHILIPS PL\* LAMP LUMINAIRE WITH PHOTOCELL

## PRODUCT INFORMATION

Catalogue No Guardlite 9  
For operation on 240V 50Hz  
will accommodate 2.5mm<sup>2</sup>  
conductors

Lamp watts - 9W

Circuit watts - 13W

Ambient temperature range -  
- 5°C to + 30°C

Weight - 900 grams

## PHOTOCELL

Manufactured by Applied  
Security Design Limited  
Switch levels

70 lux - On

140 lux - Off

## STANDARD COMPLIANCE

Guardlite 9 in type  
compliance with BS 4533 102.  
1 Class II indoor/outdoor use  
(Philips Test Report 3198)

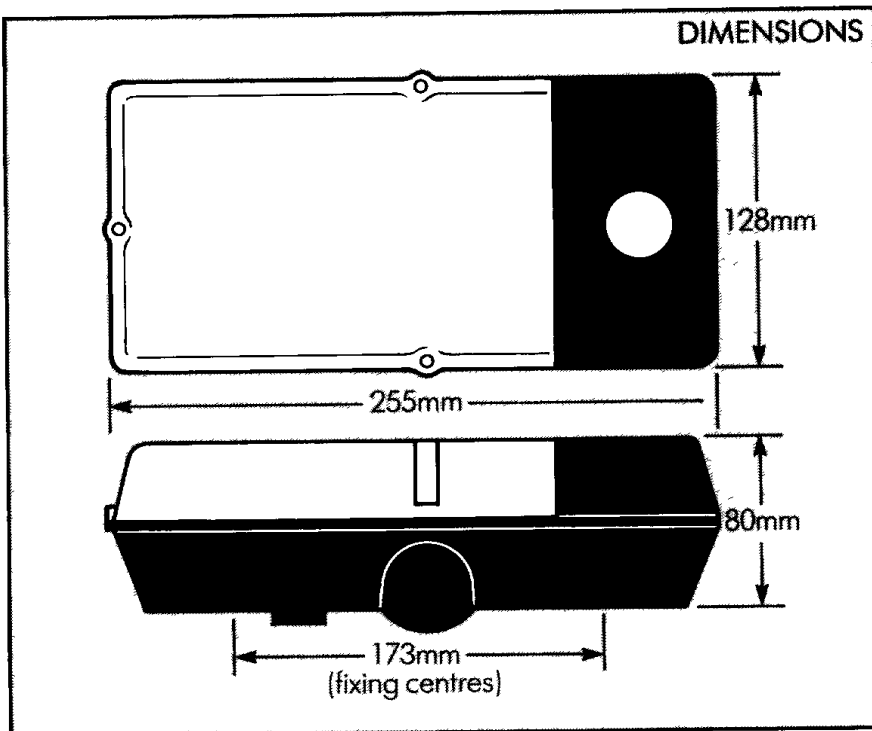

## APPLICATIONS

Wherever low-energy, low  
maintenance lighting is required

- Schools and colleges
- Passageways & corridors
- Stairways
- Offices
- Factories and warehouses
- Pedestrian underpasses
- Domestic and retail  
security lighting
- Parking areas

## TO ORDER

Applied Security Design are a new company based in  
Rotherham producing an all British Product



**APPLIED SECURITY DESIGN LTD.**

Mangham Road, Barbot Hall Industrial Estate, Rotherham, South  
Yorkshire Tel: 0709 374898 Telex: 547676 CHAMCO G (for ASD)